

P5Q SE Plus

ASUS®

Motherboard

E4182

First Edition V1
September 2008

Copyright © 2008 ASUSTeK COMPUTER INC. All Rights Reserved.

No part of this manual, including the products and software described in it, may be reproduced, transmitted, transcribed, stored in a retrieval system, or translated into any language in any form or by any means, except documentation kept by the purchaser for backup purposes, without the express written permission of ASUSTeK COMPUTER INC. ("ASUS").

Product warranty or service will not be extended if: (1) the product is repaired, modified or altered, unless such repair, modification or alteration is authorized in writing by ASUS; or (2) the serial number of the product is defaced or missing.

ASUS PROVIDES THIS MANUAL "AS IS" WITHOUT WARRANTY OF ANY KIND, EITHER EXPRESS OR IMPLIED, INCLUDING BUT NOT LIMITED TO THE IMPLIED WARRANTIES OR CONDITIONS OF MERCHANTABILITY OR FITNESS FOR A PARTICULAR PURPOSE. IN NO EVENT SHALL ASUS, ITS DIRECTORS, OFFICERS, EMPLOYEES OR AGENTS BE LIABLE FOR ANY INDIRECT, SPECIAL, INCIDENTAL, OR CONSEQUENTIAL DAMAGES (INCLUDING DAMAGES FOR LOSS OF PROFITS, LOSS OF BUSINESS, LOSS OF USE OR DATA, INTERRUPTION OF BUSINESS AND THE LIKE), EVEN IF ASUS HAS BEEN ADVISED OF THE POSSIBILITY OF SUCH DAMAGES ARISING FROM ANY DEFECT OR ERROR IN THIS MANUAL OR PRODUCT.

SPECIFICATIONS AND INFORMATION CONTAINED IN THIS MANUAL ARE FURNISHED FOR INFORMATIONAL USE ONLY, AND ARE SUBJECT TO CHANGE AT ANY TIME WITHOUT NOTICE, AND SHOULD NOT BE CONSTRUED AS A COMMITMENT BY ASUS. ASUS ASSUMES NO RESPONSIBILITY OR LIABILITY FOR ANY ERRORS OR INACCURACIES THAT MAY APPEAR IN THIS MANUAL, INCLUDING THE PRODUCTS AND SOFTWARE DESCRIBED IN IT.

Products and corporate names appearing in this manual may or may not be registered trademarks or copyrights of their respective companies, and are used only for identification or explanation and to the owners' benefit, without intent to infringe.

Contents

Contents	iii
Notices	vii
Safety information	viii
About this guide	ix
P5Q SE Plus specifications summary	xi
Chapter 1: Product introduction	
1.1 Welcome!	1-2
1.2 Package contents	1-2
1.3 Special features	1-3
1.3.1 Product highlights	1-3
1.3.2 ASUS unique features	1-4
1.3.3 ASUS Stylish features.....	1-6
1.3.4 ASUS Intelligent Overclocking features	1-6
1.4 Before you proceed	1-7
1.5 Motherboard overview	1-8
1.5.1 Placement direction	1-8
1.5.2 Screw holes	1-8
1.5.3 Motherboard layout.....	1-9
1.6 Central Processing Unit (CPU)	1-10
1.6.1 Installing the CPU	1-11
1.6.2 Installing the CPU heatsink and fan.....	1-14
1.6.3 Uninstalling the CPU heatsink and fan	1-15
1.7 System memory	1-16
1.7.1 Overview	1-16
1.7.2 Memory configurations.....	1-17
1.7.3 Installing a DIMM	1-23
1.7.4 Removing a DIMM	1-23
1.8 Expansion slots	1-24
1.8.1 Installing an expansion card	1-24
1.8.2 Configuring an expansion card	1-24
1.8.3 Interrupt assignments	1-25
1.8.4 PCI slots.....	1-26
1.8.5 PCI Express x1 slots.....	1-26
1.8.6 PCI Express 2.0 x16 slot.....	1-26
1.9 Jumpers	1-27

Contents

- 1.10 Connectors 1-29**
 - 1.10.1 Rear panel connectors..... 1-29
 - 1.10.2 Internal connectors 1-30
- 1.11 Starting up for the first time..... 1-39**
- 1.12 Turning off the computer..... 1-40**
 - 1.12.1 Using the OS shut down function..... 1-40
 - 1.12.2 Using the dual function power switch..... 1-40

- Chapter 2: BIOS setup**
 - 2.1 Managing and updating your BIOS 2-2**
 - 2.1.1 ASUS Update utility 2-2
 - 2.1.2 Creating a bootable floppy disk..... 2-5
 - 2.1.3 ASUS EZ Flash 2 utility..... 2-6
 - 2.1.4 AFUDOS utility..... 2-7
 - 2.1.5 ASUS CrashFree BIOS 3 utility 2-9
 - 2.2 BIOS setup program 2-10**
 - 2.2.1 BIOS menu screen.....2-11
 - 2.2.2 Menu bar.....2-11
 - 2.2.3 Navigation keys.....2-11
 - 2.2.4 Menu items 2-12
 - 2.2.5 Sub-menu items..... 2-12
 - 2.2.6 Configuration fields 2-12
 - 2.2.7 Pop-up window 2-12
 - 2.2.8 Scroll bar..... 2-12
 - 2.2.9 General help 2-12
 - 2.3 Main menu 2-13**
 - 2.3.1 System Time 2-13
 - 2.3.2 System Date 2-13
 - 2.3.3 Legacy Diskette A 2-13
 - 2.3.4 SATA 1-6..... 2-14
 - 2.3.5 Storage Configuration 2-15
 - 2.3.6 System Information 2-16
 - 2.4 Ai Tweaker menu..... 2-17**
 - 2.4.1 Ai Overclock Tuner 2-17
 - 2.4.2 FSB Strap to North Bridge 2-18
 - 2.4.3 DRAM Frequency 2-18

Contents

2.4.4	DRAM Timing Control	2-18
2.4.5	DRAM Static Read Control	2-20
2.4.6	DRAM Read Training	2-20
2.4.7	MEM. OC Charger	2-20
2.4.8	Ai Clock Twister	2-20
2.4.9	Ai Transaction Booster	2-21
2.4.10	CPU Voltage	2-21
2.4.11	FSB Termination Voltage	2-21
2.4.12	Memory Voltage	2-21
2.4.13	North Bridge Voltage	2-21
2.4.14	South Bridge Voltage	2-22
2.4.15	Load-Line Calibration	2-22
2.4.16	CPU GTL Reference	2-22
2.4.17	CPU Spread Spectrum	2-22
2.4.18	PCIE Spread Spectrum	2-22
2.4.19	CPU Clock Skew	2-22
2.4.20	NB Clock Skew	2-22
2.4.21	CPU Margin Enhancement	2-22
2.5	Advanced menu	2-23
2.5.1	CPU Configuration	2-23
2.5.2	Chipset.....	2-25
2.5.3	OnBoard Devices Configuration	2-26
2.5.4	USB Configuration	2-27
2.5.5	PCI PnP	2-28
2.6	Power menu.....	2-29
2.6.1	Suspend Mode	2-29
2.6.2	Repost Video on S3 Resume.....	2-29
2.6.3	ACPI 2.0 Support.....	2-29
2.6.4	ACPI APIC Support.....	2-29
2.6.5	APM Configuration.....	2-30
2.6.6	Hardware Monitor	2-31
2.7	Boot menu	2-33
2.7.1	Boot Device Priority	2-33
2.7.2	Boot Settings Configuration	2-34
2.7.3	Security	2-35

Contents

2.8	Tools menu	2-37
2.8.1	ASUS EZ Flash 2	2-37
2.8.2	Express Gate	2-38
2.8.3	AI NET 2.....	2-38
2.8.4	ASUS O.C. Profile.....	2-39
2.9	Exit menu.....	2-40

Chapter 3: Software support

3.1	Installing an operating system	3-2
3.2	Support DVD information	3-2
3.2.1	Running the support DVD	3-2
3.2.2	Drivers menu.....	3-3
3.2.3	Utilities menu	3-4
3.2.4	Manual menu	3-6
3.2.5	ASUS Contact information	3-6
3.2.6	Other information	3-7

Notices

Federal Communications Commission Statement

This device complies with Part 15 of the FCC Rules. Operation is subject to the following two conditions:

- This device may not cause harmful interference, and
- This device must accept any interference received including interference that may cause undesired operation.

This equipment has been tested and found to comply with the limits for a Class B digital device, pursuant to Part 15 of the FCC Rules. These limits are designed to provide reasonable protection against harmful interference in a residential installation. This equipment generates, uses and can radiate radio frequency energy and, if not installed and used in accordance with manufacturer's instructions, may cause harmful interference to radio communications. However, there is no guarantee that interference will not occur in a particular installation. If this equipment does cause harmful interference to radio or television reception, which can be determined by turning the equipment off and on, the user is encouraged to try to correct the interference by one or more of the following measures:

- Reorient or relocate the receiving antenna.
- Increase the separation between the equipment and receiver.
- Connect the equipment to an outlet on a circuit different from that to which the receiver is connected.
- Consult the dealer or an experienced radio/TV technician for help.



The use of shielded cables for connection of the monitor to the graphics card is required to assure compliance with FCC regulations. Changes or modifications to this unit not expressly approved by the party responsible for compliance could void the user's authority to operate this equipment.

Canadian Department of Communications Statement

This digital apparatus does not exceed the Class B limits for radio noise emissions from digital apparatus set out in the Radio Interference Regulations of the Canadian Department of Communications.

This class B digital apparatus complies with Canadian ICES-003.

Safety information

Electrical safety

- To prevent electrical shock hazard, disconnect the power cable from the electrical outlet before relocating the system.
- When adding or removing devices to or from the system, ensure that the power cables for the devices are unplugged before the signal cables are connected. If possible, disconnect all power cables from the existing system before you add a device.
- Before connecting or removing signal cables from the motherboard, ensure that all power cables are unplugged.
- Seek professional assistance before using an adapter or extension cord. These devices could interrupt the grounding circuit.
- Make sure that your power supply is set to the correct voltage in your area. If you are not sure about the voltage of the electrical outlet you are using, contact your local power company.
- If the power supply is broken, do not try to fix it by yourself. Contact a qualified service technician or your retailer.

Operation safety

- Before installing the motherboard and adding devices on it, carefully read all the manuals that came with the package.
- Before using the product, make sure all cables are correctly connected and the power cables are not damaged. If you detect any damage, contact your dealer immediately.
- To avoid short circuits, keep paper clips, screws, and staples away from connectors, slots, sockets and circuitry.
- Avoid dust, humidity, and temperature extremes. Do not place the product in any area where it may become wet.
- Place the product on a stable surface.
- If you encounter technical problems with the product, contact a qualified service technician or your retailer.



This symbol of the crossed out wheeled bin indicates that the product (electrical and electronic equipment, Mercury-containing button cell battery) should not be placed in municipal waste. Check local regulations for disposal of electronic products.

About this guide

This user guide contains the information you need when installing and configuring the motherboard.

How this guide is organized

This guide contains the following parts:

- **Chapter 1: Product introduction**
This chapter describes the features of the motherboard and the new technology it supports. This chapter also lists the hardware setup procedures that you have to perform when installing system components. It includes description of the jumpers and connectors on the motherboard.
- **Chapter 2: BIOS setup**
This chapter tells how to change system settings through the BIOS Setup menus. Detailed descriptions of the BIOS parameters are also provided.
- **Chapter 3: Software support**
This chapter describes the contents of the support CD that comes with the motherboard package.

Where to find more information

Refer to the following sources for additional information and for product and software updates.

1. **ASUS websites**
The ASUS website provides updated information on ASUS hardware and software products. Refer to the ASUS contact information.
2. **Optional documentation**
Your product package may include optional documentation, such as warranty flyers, that may have been added by your dealer. These documents are not part of the standard package.

Conventions used in this guide

To make sure that you perform certain tasks properly, take note of the following symbols used throughout this manual.



DANGER/WARNING: Information to prevent injury to yourself when trying to complete a task.



CAUTION: Information to prevent damage to the components when trying to complete a task.



IMPORTANT: Instructions that you **MUST** follow to complete a task.



NOTE: Tips and additional information to help you complete a task.

Typography

Bold text

Indicates a menu or an item to select.

Italics

Used to emphasize a word or a phrase.

<Key>

Keys enclosed in the less-than and greater-than sign means that you must press the enclosed key.

Example: <Enter> means that you must press the Enter or Return key.

<Key1>+<Key2>+<Key3>

If you must press two or more keys simultaneously, the key names are linked with a plus sign (+).

Example: <Ctrl>+<Alt>+<D>

Command

Means that you must type the command exactly as shown, then supply the required item or value enclosed in brackets.

Example: At the DOS prompt, type the command line:

```
a.fudos /i [filename]
```

```
a.fudos /iP5QSEPLU.ROM
```

P5Q SE Plus specifications summary

CPU	LGA775 socket for Intel® Core™2 Extreme / Core™2 Quad / Core™2 Duo / Pentium® dual-core / Celeron® dual-core / Celeron® processors Compatible with Intel® 05B/05A/06 processors Supports Intel® 45nm Multi-Core CPU
Chipset	Intel® P45 / ICH10 with Intel® Fast Memory Access Technology
System Bus	1600 / 1333 / 1066 / 800 MHz
Memory	Dual-channel memory architecture <ul style="list-style-type: none"> - 4 x 240-pin DIMM sockets support unbuffered non-ECC DDR2 1200 / 1066 / 800 / 667 MHz memory modules - Supports up to 16GB system memory • Refer to www.asus.com or this user manual for the memory QVL (Qualified Vendors List.) • Due to chipset limitation, when installing total memory of 4GB capacity or more, Windows® 32-bit operation system may only recognize less than 3GB. Hence, a total installed memory of less than 3GB is recommended.
Expansion Slots	1 x PCI Express 2.0 x16 slot 2 x PCI Express x1 slots 3 x PCI slots
Storage	Southbridge <ul style="list-style-type: none"> - 6 x Serial ATA 3.0Gb/s ports JMicron® JMB368 <ul style="list-style-type: none"> - 1 x UltraDMA 133 / 100 / 66 for up to 2 PATA devices
ASUS Unique Features	ASUS Power Saving Solution: <ul style="list-style-type: none"> - ASUS 8-Phase Power Design - ASUS EPU-4 Engine - ASUS AI Nap ASUS Exclusive Feature: <ul style="list-style-type: none"> - ASUS Express Gate ASUS Quiet Thermal Solution: <ul style="list-style-type: none"> - ASUS Fan Xpert - ASUS Fanless Design: Heatsink Solution ASUS EZ DIY: <ul style="list-style-type: none"> - ASUS Q-Connector - ASUS O.C. Profile - ASUS CrashFree BIOS 3 - ASUS EZ Flash 2
Other Features	ASUS MyLogo2
LAN	Realtek Gigabit LAN controller featuring AI NET 2
Audio	VIA® AVT1708s, 8-channel High-Definition Audio CODEC <ul style="list-style-type: none"> - Supports Multi-streaming - Optical S/PDIF out port at back I/O - ASUS Noise Filtering

(continued on the next page)

P5Q SE Plus specifications summary

USB	12 x USB 2.0 ports (6 ports at mid-board, 6 ports at back panel)
ASUS Exclusive Overclocking Features	<p>Intelligent overclocking tools:</p> <ul style="list-style-type: none"> - ASUS AI Booster utility <p>Precision Tweaker:</p> <ul style="list-style-type: none"> - vCore: Adjustable CPU voltage at 6.25mV increment - vDIMM: 6-step DRAM voltage control <p>SFS (Stepless Frequency Selection):</p> <ul style="list-style-type: none"> - FSB tuning from 200MHz to 800 MHz at 1MHz increment - Memory tuning from 667MHz up to 1333MHz for DDR2 - PCI Express frequency tuning from 100MHz to 180MHz at 1MHz increment <p>Overclocking protection:</p> <ul style="list-style-type: none"> - ASUS C.P.R. (CPU Parameter Recall)
Back Panel I/O Ports	<p>1 x PS/2 keyboard port 1 x PS/2 mouse port 1 x optical S/PDIF Out port 1 x RJ-45 port 6 x USB 2.0/1.1 ports 8-channel audio I/O ports</p>
Internal I/O Connectors	<p>3 x USB connectors support 6 additional USB ports 1 x Floppy disk drive connector 1 x IDE connector 6 x Serial ATA connectors 1 x CPU/ Chassis/ Power fan connector 1 x COM connector 1 x S/PDIF Out header 1 x Chassis intrusion connector 1 x Front panel audio connector 1 x CD audio in connector 1 x 24-pin ATX power connector 1 x 4-pin ATX 12V power connector System panel connector (Q-Connector)</p>
Manageability	WfM 2.0, DMI 2.0, WOL by PME, WOR by PME, PXE
BIOS Features	8Mb Flash ROM, AMI BIOS, PnP, DMI 2.0, WfM 2.0, SM BIOS 2.3, ACPI 2.0a, ASUS EZ Flash 2, ASUS CrashFree BIOS 3
Support DVD	<p>Drivers ASUS PC Probe II ASUS Update ASUS AI Suite Anti-Virus software (OEM version)</p>
BIOS Features	ATX form factor: 12 in x 7.8 in (30.5 cm x 19.8 cm)

*Specifications are subject to change without notice.

This chapter describes the motherboard features and the new technologies it supports.

1 Product introduction

1.1 Welcome!

Thank you for buying an ASUS® P5Q SE Plus motherboard!

The motherboard delivers a host of new features and latest technologies, making it another standout in the long line of ASUS quality motherboards!

Before you start installing the motherboard, and hardware devices on it, check the items in your package with the list below.

1.2 Package contents

Check your motherboard package for the following items.

Motherboard	ASUS P5Q SE Plus motherboard
Cables	2 x Serial ATA cables 1 x Ultra DMA 133/100/66 cable
Accessories	1 x I/O shield 2 in 1 Q-Connector (Retail version only)
Application DVD	ASUS motherboard support DVD
Documentation	User guide



If any of the above items is damaged or missing, contact your retailer.

1.3 Special features

1.3.1 Product highlights

Green ASUS



This motherboard and its packaging comply with the European Union's Restriction on the use of Hazardous Substances (RoHS). This is in line with the ASUS vision of creating environment-friendly and recyclable products/packaging to safeguard consumers' health while minimizing the impact on the environment.

Intel® Core™2 Extreme / Core™2 Quad / Core™2 Duo CPU support



This motherboard supports the latest Intel® Core™2 processor in the LGA775 package and Intel's 45nm multi-core processors. With the new Intel® Core™ microarchitecture technology and 1333/1066/800 MHz FSB, the Intel® Core™2 is one of the most powerful and energy efficient CPUs in the world. See page 1-10 for details.

Intel® P45 Chipset

The Intel® P45 Express Chipset is designed to support dual-channel DDR2 1066/800/667MHz architecture, 1333/1066/800 FSB (Front Side Bus), PCIe 2.0, and multi-core CPUs. It supports Intel Fast Memory Access technology that significantly optimizes the use of available memory bandwidth and reduces the latency of the memory accesses.

PCI Express 2.0 support



The motherboard supports the latest PCI Express 2.0 devices for double speed and bandwidth which enhances system performance. See page 1-26 for details.

FSB 1600 support



ASUS's exclusive overclocking design now unleashes the ultimate potential of the Intel® Core™2 processor. With the new Intel 45nm micro-architecture technology and FSB 1600 / 1333 / 1066 / 800 MHz, this motherboard allows you to enjoy the latest technology supported by one of the most powerful and energy efficient CPUs in the world.

Serial ATA 3Gb/s technology



This motherboard supports the hard drives based on the Serial ATA (SATA) 3Gb/s storage specification, delivering enhanced scalability and doubling the bus bandwidth for high-speed data retrieval and saves. See page 1-32 for details.

1.3.2 ASUS unique features

ASUS Exclusive features

Express Gate

Taking only 5 seconds to go online from bootup, Express Gate is the one-stop gateway to instant fun! It's a unique motherboard built-in OS. You can utilize the most popular Instant Messengers (IM) like MSN, Skype, Google talk, QQ, and Yahoo! Messenger to keep in touch with friends, or quickly check on the weather and e-mails just before leaving your house. What's more, the user-friendly picture manager lets you view your pictures without entering Windows at anytime!



-
- The actual boot time depends on the system configuration.
 - File downloading and uploading progresses through USB devices only.
-

ASUS Power Saving Solution

ASUS Power Saving solution intelligently and automatically provides balanced computing power and energy consumption.

ASUS 8-Phase Power Design

ASUS 8-Phase Power Design keeps CPU and power module away from suffering risk of high power stress, which makes CPU lifetime much longer and system more stable. With High quality power components such as low RDS (on) MOSFETs for minimum switching loss & lower temperatures, Ferrite core chokes with lower hysteresis loss and high quality conductive polymer capacitors, it provides high efficiency operation to generate less heat than conventional power solutions and consequently achieve cool system environment.

ASUS EPU-4 Engine

The new ASUS EPU - the world's first power saving engine, has been upgraded to a new four-engine version, which provides total system power savings by detecting current PC loadings and intelligently moderating power in real-time. The EPU automatically provides the most appropriate power usage for the CPU, VGA card, hard drives, CPU fan, and chassis fan - helping save power and money.

AI Nap

With AI Nap, the system can continue running at minimum power and noise when you are temporarily away. To wake the system and return to the OS environment, simply click the mouse or press a key.

ASUS Quiet Thermal Solution

ASUS Quiet Thermal solution makes system more stable and enhances the overclocking capability.

Fan Xpert

ASUS Fan Xpert intelligently allows users to adjust both the CPU and chassis fan speed according to different ambient temperature, which is caused by different climate conditions in different geographic regions and system loading. Built-in variety of useful profiles offer flexible controls of fan speed to achieve a quiet and cool environment.

ASUS EZ DIY

ASUS EZ DIY feature collection provides you easy ways to install computer components, update the BIOS or back up your favorite settings.

ASUS Q-Connector

ASUS Q-Connector allows you to easily connect or disconnect the chassis front panel cables to the motherboard. This unique module eliminates the trouble of connecting the system panel cables one at a time and avoiding wrong cable connections. See page 1-38 for details.

ASUS O.C. Profile

The motherboard features the ASUS O.C. Profile that allows users to conveniently store or load multiple BIOS settings. The BIOS settings can be stored in the CMOS or a separate file, giving users freedom to share and distribute their favorite settings. See page 2-39 for details.

ASUS CrashFree BIOS 3

The ASUS CrashFree BIOS 3 allows users to restore corrupted BIOS data from a USB flash disk containing the BIOS file. See page 2-9 for details.

ASUS EZ Flash 2



EZ Flash 2 is a user-friendly BIOS update utility. Simply press the predefined hotkey to launch the utility and update the BIOS without entering the OS. Update your BIOS easily without preparing a bootable diskette or using an OS-based flash utility. See pages 2-6 and 2-37 for details.

1.3.3 ASUS Stylish features

ASUS MyLogo2™



This feature allows you to convert your favorite photo into a 256-color boot logo for a more colorful and vivid image on your screen. See page 2-34 for details.

1.3.4 ASUS Intelligent Overclocking features

AI Booster

The ASUS AI Booster allows you to overclock the CPU speed in Windows environment without the hassle of booting the BIOS.

Precision Tweaker



This feature allows you to fine tune the CPU/memory voltage and gradually increase the memory Front Side Bus (FSB) and PCI Express frequency at 1MHz increment to achieve maximum system performance. See page 2-21 for details.

C.P.R. (CPU Parameter Recall)



The C.P.R. feature of the motherboard BIOS allows automatic re-setting to the BIOS default settings in case the system hangs due to overclocking. When the system hangs due to overclocking, C.P.R. eliminates the need to open the system chassis and clear the RTC data. Simply shut down and reboot the system, and the BIOS automatically restores the CPU default setting for each parameter.

1.4 Before you proceed

Take note of the following precautions before you install motherboard components or change any motherboard settings.



- Unplug the power cord from the wall socket before touching any component.
- Use a grounded wrist strap or touch a safely grounded object or a metal object, such as the power supply case, before handling components to avoid damaging them due to static electricity.
- Hold components by the edges to avoid touching the ICs on them.
- Whenever you uninstall any component, place it on a grounded antistatic pad or in the bag that came with the component.
- Before you install or remove any component, ensure that the ATX power supply is switched off or the power cord is detached from the power supply. Failure to do so may cause severe damage to the motherboard, peripherals, and/or components.

Onboard LED

The motherboard comes with a standby power LED that lights up to indicate that the system is ON, in sleep mode, or in soft-off mode. This is a reminder that you should shut down the system and unplug the power cable before removing or plugging in any motherboard component. The illustration below shows the location of the onboard LED.

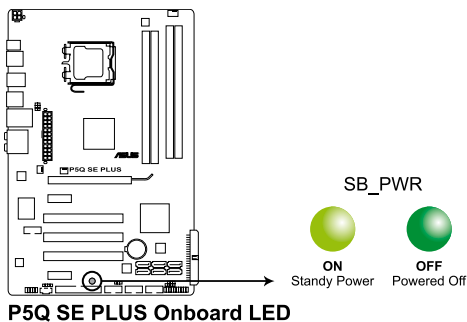

1.5 Motherboard overview

Before you install the motherboard, study the configuration of your chassis to ensure that the motherboard fits into it.



Ensure to unplug the power cord before installing or removing the motherboard. Failure to do so can cause you physical injury and damage motherboard components.

1.5.1 Placement direction

When installing the motherboard, ensure that you place it into the chassis in the correct orientation. The edge with external ports goes to the rear part of the chassis as indicated in the image below.

1.5.2 Screw holes

Place six (6) screws into the holes indicated by circles to secure the motherboard to the chassis.



Do not overtighten the screws! Doing so can damage the motherboard.

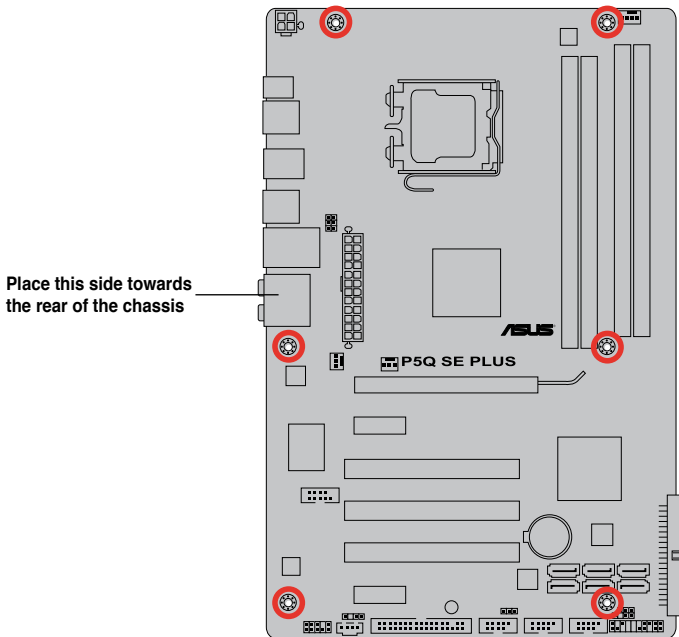

1.5.3 Motherboard layout

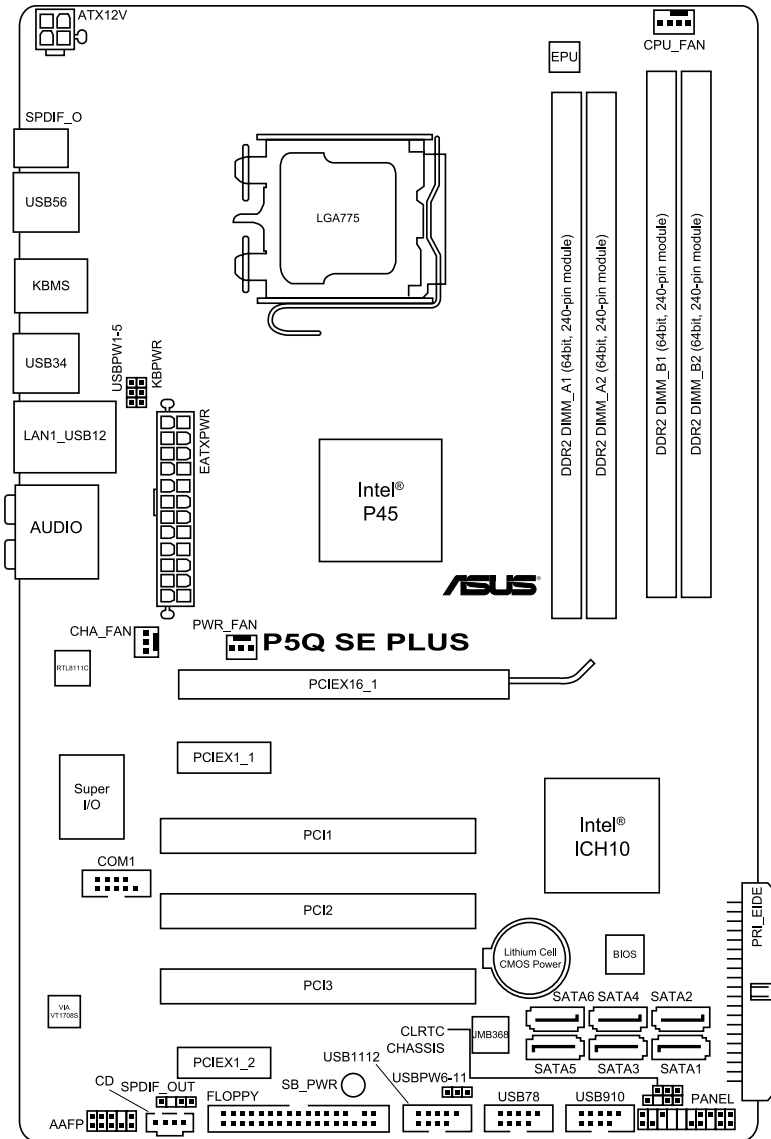

Refer to **1.10 Connectors** for more information about rear panel connectors and internal connectors.

1.6 Central Processing Unit (CPU)

The motherboard comes with a surface mount LGA775 socket designed for the Intel® Core™2 Extreme / Core™2 Quad / Core™2 Duo / Pentium® dual-core / Celeron® dual-core / Celeron® processors.



-
- Ensure that all power cables are unplugged before installing the CPU.
 - Connect the chassis fan cable to the CHA_FAN connector to ensure system stability.
 - Due to chipset limitation, we recommend you use FSB 800 MHz CPU or above.
-



-
- Upon purchase of the motherboard, ensure that the PnP cap is on the socket and the socket contacts are not bent. Contact your retailer immediately if the PnP cap is missing, or if you see any damage to the PnP cap/socket contacts/motherboard components. ASUS will shoulder the cost of repair only if the damage is shipment/transit-related.
 - Keep the cap after installing the motherboard. ASUS will process Return Merchandise Authorization (RMA) requests only if the motherboard comes with the cap on the LGA775 socket.
 - The product warranty does not cover damage to the socket contacts resulting from incorrect CPU installation/removal, or misplacement/loss/incorrect removal of the PnP cap.
-

1.6.1 Installing the CPU

To install a CPU:

1. Locate the CPU socket on the motherboard.

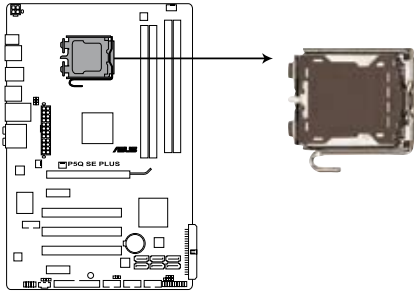

P5Q SE PLUS CPU socket 775



Before installing the CPU, ensure that the socket box is facing towards you and the load lever is on your left.

2. Press the load lever with your thumb (A), then move it to the left (B) until it is released from the retention tab.



To prevent damage to the socket pins, do not remove the PnP cap unless you are installing a CPU.

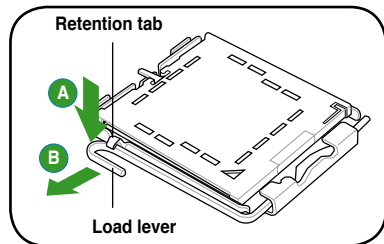

3. Lift the load lever in the direction of the arrow to a 135° angle.
4. Lift the load plate with your thumb and forefinger to a 100° angle (4A), then push the PnP cap from the load plate window to remove (4B).

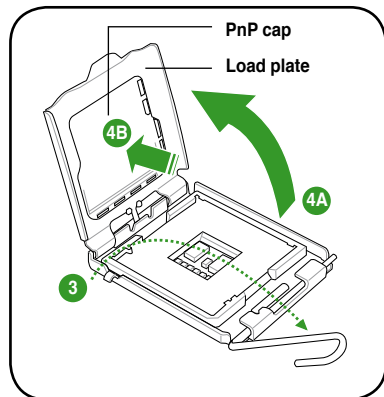

5. Position the CPU over the socket, ensuring that the gold triangle is on the bottom-left corner of the socket then fit the socket alignment key into the CPU notch.



The CPU fits in only one correct orientation. **DO NOT** force the CPU into the socket to prevent bending the connectors on the socket and damaging the CPU!

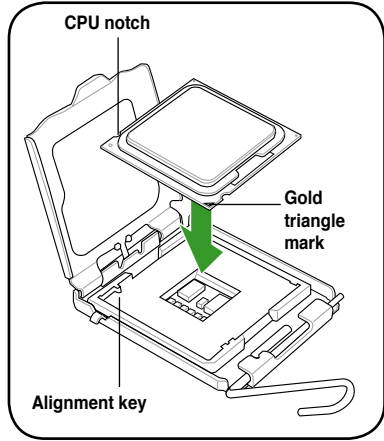

6. Apply several drops of thermal paste to the exposed area of the CPU that the heatsink will be in contact with, ensuring that it is spread in an even thin layer.



Some heatsinks come with pre-applied thermal paste. If so, skip this step.

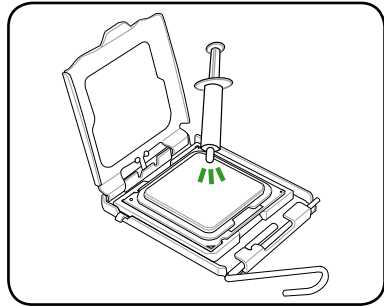

The Thermal Interface Material is toxic and inedible. If it gets into your eyes or touches your skin, ensure to wash it off immediately, and seek professional medical help.



To prevent contaminating the paste, **DO NOT** spread the paste with your finger directly.

7. Close the load plate (A), then push the load lever (B) until it snaps into the retention tab.

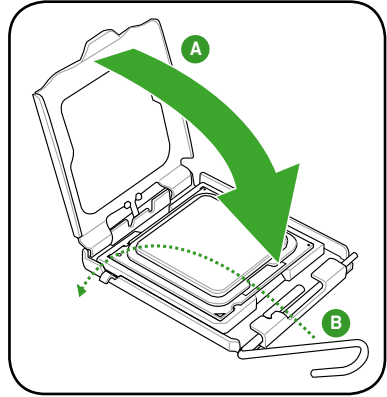

1.6.2 Installing the CPU heatsink and fan

The Intel® LGA775 processor requires a specially designed heatsink and fan assembly to ensure optimum thermal condition and performance.



- When you buy a boxed Intel® processor, the package includes the CPU fan and heatsink assembly. If you buy a CPU separately, ensure that you use only Intel®-certified multi-directional heatsink and fan.
- Your Intel® LGA775 heatsink and fan assembly comes in a push-pin design and requires no tool to install.
- If you purchased a separate CPU heatsink and fan assembly, ensure that you have properly applied Thermal Interface Material to the CPU heatsink or CPU before you install the heatsink and fan assembly.



Ensure that you have installed the motherboard to the chassis before you install the CPU fan and heatsink assembly.



If you purchased a separate CPU heatsink and fan assembly, ensure that that Thermal Interface Material is properly applied to the CPU heatsink or CPU before you install the heatsink and fan assembly.

To install the CPU heatsink and fan:

1. Place the heatsink on top of the installed CPU, making sure that the four fasteners match the holes on the motherboard.
2. Push down two fasteners at a time in a diagonal sequence to secure the heatsink and fan assembly in place.

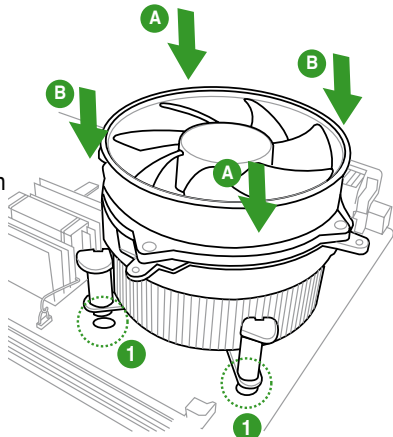
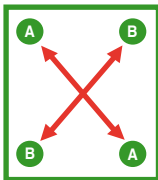

The type of CPU heatsink and fan assembly may differ, but the installation steps and functions should remain the same. The illustration above is for reference only.

3. Connect the CPU fan cable to the connector on the motherboard labeled CPU_FAN.

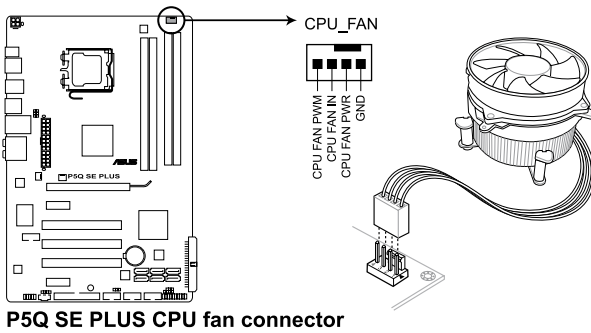

Do not forget to connect the CPU fan connector! Hardware monitoring errors can occur if you fail to plug this connector.

1.6.3 Uninstalling the CPU heatsink and fan

To uninstall the CPU fan and heatsink

1. Disconnect the CPU fan cable from the connector on the motherboard.
2. Rotate each fastener counterclockwise.
3. Pull up two fasteners at a time in a diagonal sequence to disengage the heatsink and fan assembly from the motherboard.

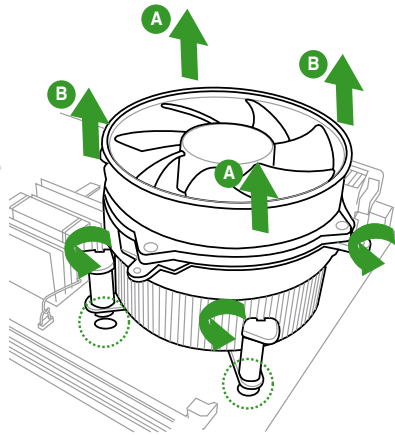
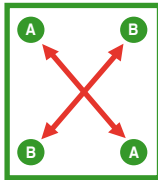

4. Carefully remove the heatsink and fan assembly from the motherboard.

1.7 System memory

1.7.1 Overview

The motherboard comes with four Double Data Rate 2 (DDR2) Dual Inline Memory Modules (DIMM) sockets.

A DDR2 module has the same physical dimensions as a DDR DIMM but has a 240-pin footprint compared to the 184-pin DDR DIMM. DDR2 DIMMs are not notched differently to prevent installation on a DDR DIMM socket.

The figure illustrates the location of the DDR2 DIMM sockets:

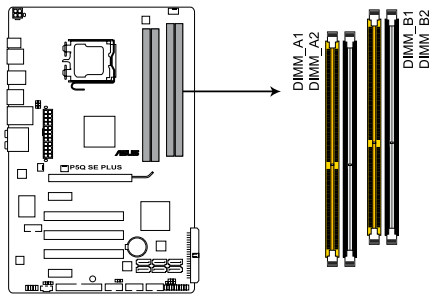

P5Q SE PLUS 240-pin DDR2 DIMM sockets

Channel	Sockets
Channel A	DIMM_A1 and DIMM_A2
Channel B	DIMM_B1 and DIMM_B2

1.7.2 Memory configurations

You may install 512 MB, 1 GB, 2 GB, and 4 GB unbuffered non-ECC DDR2 DIMMs into the DIMM sockets.



-
- You may install varying memory sizes in Channel A and Channel B. The system maps the total size of the lower-sized channel for the dual-channel configuration. Any excess memory from the higher-sized channel is then mapped for single-channel operation.
 - It is recommended to install the memory modules from the yellow slots for better overclocking capability.
 - Always install DIMMs with the same CAS latency. For optimum compatibility, it is recommended that you obtain memory modules from the same vendor.
 - Due to the memory address limitation on 32-bit Windows OS, when you install 4GB or more memory on the motherboard, the actual usable memory for the OS can be about 3GB or less. For effective use of memory, we recommend that you install a 64-bit Windows OS when having 4GB or more memory installed on the motherboard.
 - This motherboard does not support memory modules made up of 128 Mb chips.
-



-
- The default memory operation frequency is dependent on its SPD. Under the default state, some memory modules for overclocking may operate at a lower frequency than the vendor-marked value. To operate at the vendor-marked or at a higher frequency, see section **2.4 Ai Tweaker menu** for manual memory frequency adjustment.
 - The memory modules may require a better cooling system to work stably under full loading (4 DIMMs) or overclocking setting.
-

P5Q SE Plus Motherboard Qualified Vendors Lists (QVL) DDR2-1066 MHz capability

Size	Vendor	Part No.	CL	Chip Brand	SS/ DS	Chip No.	DIMM support		
							A*	B*	C*
1G	Kingston	KVR1066D2N7/1G	N/A	Elpida	DS	E5108AJBG-1J-E	*	*	*
1G	Kingston	KHX8500D2/1G	N/A	Kingston	DS	Heat-Sink Package	*	*	*
512MB	Kingston	KHX8500D2/512	N/A	Kingston	SS	Heat-Sink Package	*	*	*
512MB	Kingston	KVR1066D2N7/512	N/A	Elpida	SS	E5108AJBG-1J-E	*	*	*
512MB	Kingston	KHX8500D2K2/1GN	N/A	Kingston	SS	Heat-Sink Package	*	*	*
1G	Kingston	KHX8500D2K2/2GN	N/A	Kingston	DS	Heat-Sink Package	*	*	*
1G	Qimonda	HYS64T128020EU-19F-C	6	Qimonda	DS	HYB18T512800CF19FFSS24313	*	*	*
1G	Corsair	CM2X1024-8500C5D	5-5-5-15	Corsair	SS	Heat-Sink Package	*	*	*
1G	Transcend	TX1066QLJ-2GK1GB	5	Transced	DS	Heat-Sink Package	*	*	*
1G	Kingmax	KLED48F-A8K15	N/A	Kingmax	DS	KK48FFIXF-JFS-18A	*	*	*
2G(kit of 2)	OCZ	OCZ2N1066SR2DK	5-5-5-15	OCZ	DS	Heat-Sink Package(EPP)	*	*	*
1G	GEIL	GB22GB8500C5DC	5	GEIL	SS	GL2L128M88BA25AB	*	*	*
1G	GEIL	GB24GB8500C5QC	5	GEIL	SS	GL2L128M88BA25AB	*	*	*
1G	GEIL	GE22GB1066C5DC	5	GEIL	DS	Heat-Sink Package	*	*	*
1G	GEIL	GE24GB1066C5QC	5	GEIL	DS	Heat-Sink Package	*	*	*
2G	GEIL	GB24GB8500C5DC	5	GEIL	DS	GL2L128M88BA25AB	*	*	*
2G(kit of 2)	G.SKILL	F2-8500CL5D-2GBPK	5-5-5-15	N/A	DS	Heat-Sink Package	*	*	*
4G(kit of 2)	G.SKILL	F2-8500CL5D-4GBPK	5-5-5-15	N/A	DS	Heat-Sink Package	*	*	*
1G	G.SKILL	F2-8500CL5S-1GBPK	5-5-5-15	G.SKILL	DS	Heat-Sink Package	*	*	*
512MB	Kingbox	EP512D21066PS	N/A	Micron	SS	6QD22D9GCT	*	*	*
1G	AENEON	AXT760UD00-19DC37X	5	AENEON	DS	Heat-Sink Package	*	*	*

DDR2-800 MHz capability

Size	Vendor	Part No.	CL	Chip Brand	SS/ DS	Chip No.	DIMM support		
							A*	B*	C*
1G	Kingston	KHX6400D2LL/1G	N/A	Kingston	DS	Heat-Sink Package	*	*	*
512MB	Kingston	KVR800D2N5/512	N/A	Promos	SS	V59C1512804QCF25SY0324 06PECPA	*	*	*
512MB	Kingston	KHX6400D2LLK2/1GN	N/A	Kingston	SS	Heat-Sink Package	*	*	*
512MB	Kingston	KVR800D2N6/512	N/A	Elpida	SS	E5108AJBG-8E-E	*	*	*
1G	Kingston	KVR800D2N5/1G	N/A	Elpida	DS	E5108AJBG-8E-E	*	*	*
2G	Kingston	KHX6400D2/2G	N/A	Kingston	DS	Heat-Sink Package	*	*	*
1G	Kingston	KVR800D2N6/1G	N/A	Elpida	DS	E5108AJBG-8E-E	*	*	*
1G	Samsung	K4T1G084QQ-HCF7	6	Samsung	SS	M378T2863QZS-CF7	*	*	*
2G	Kingston	KVR800D2N5/2G	N/A	Elpida	DS	E1108ACBG-8E-E	*	*	*

(continued on the next page)

DDR2-800 MHz capability

Size	Vendor	Chip No.	CL	Chip Brand	SS/ DS	Part No.	DIMM support		
							A*	B*	C*
4G	Kingston	E2108ABSE-8G-E	N/A	Elpida	DS	N/A	.	.	.
1G	Samsung	K4T51083QG-HCF7	6	Samsung	DS	M378T2953GZ3-CF7	.	.	.
2G	Samsung	K4T1G084QQ-HCF7	6	Samsung	DS	M378T5663QZ3-CF7	.	.	.
512MB	Samsung	K4T51083QG-HCF7	6	Samsung	SS	M378T6553GZS-CF7	.	.	.
4G	Samsung	K4T2G084QA-HCF7	6	Samsung	DS	M378T5263AZ3-CF7	.	.	.
1G	Qimonda	HYB18T512800B2F25F SS28380	6	Qimonda	DS	HYS64T128020EU-2.5-B2	.	.	.
512MB	Qimonda	HYB18T512800B2F25F SS28380	6	Qimonda	SS	HYS64T64000EU-2.5-B2	.	.	.
1G	Corsair	Heat-Sink Package	4	Corsair	DS	XMS2-6400	.	.	.
1G	Corsair	Heat-Sink Package	5	Corsair	DS	XMS2-6400	.	.	.
2G(Kit of 2)	Corsair	Heat-Sink Package	5	Corsair	DS	CM2X2048-6400C5DHX	.	.	.
2G(Kit of 2)	Corsair	Heat-Sink Package	5	Corsair	DS	CM2X2048-6400C5	.	.	.
1G	HY	HY5PS12821CFPS5	5	Hynix	DS	HYMP512U64CP8-S5 AB	.	.	.
512MB	HY	HY5PS12821CFP-S5	5	Hynix	SS	HYMP564U64CP8-S5 AB	.	.	.
512MB	Kingmax	KK48FF1XF-JFS-25A	N/A	Kingmax	SS	KLDC28F-A8K15	.	.	.
1G	Apacer	AM4B5808CQJS8E0749D	5	Apacer	SS	78.01GA0.9K5	.	.	.
2G	Apacer	AM4B5808CQJS8E0747D	5	Apacer	DS	78.A1GA0.9K4	.	.	.
512MB	Apacer	AM4B5708JQJS8E0751C	5	Apacer	SS	78.91G91.9K5	.	.	.
2G	Apacer	AM4B5808CQJS8E0740E	5	Apacer	DS	78.A1GA0.9K4	.	.	.
512MB	Transcend	7HD22 D9GMH	N/A	Micron	SS	TS128MLQ64V8J512MB	.	.	.
512MB	Transcend	Heat-Sink Package	N/A	Transcend	SS	TS64MLQ64V8J512MB	.	.	.
512MB	ADATA	AD29608A8A- 25EG80812	N/A	ADATA	SS	M20AD6G3H3160Q1E58	.	.	.
512MB	VDATA	VD29608A8A- 25EG20813	N/A	VDATA	SS	M2GV6D6G3H3160Q1E52	.	.	.
1G	ADATA	AD29608A8A- 25EG80810	N/A	ADATA	DS	M20AD6G314170Q1E58	.	.	.
1G	VDATA	VD29608A8A- 25EG80813	N/A	VDATA	DS	M2GV6D6G314170Q1E58	.	.	.
1G	PSC	A3R1GE3CFF734MAA0E	5	PSC	SS	AL7E8F73C-8E1	.	.	.
2G	PSC	A3R1GE3CFF734MAA0E	5	PSC	DS	AL8E8F73C-8E1	.	.	.
1G	GEIL	GL2L64M088BA30EB	4	GEIL	DS	GB22GB6400C4DC	.	.	.
1G	GEIL	GL2L64M088BA30EB	4	GEIL	DS	GB24GB6400C4QC	.	.	.
1G	GEIL	GL2L64M088BA30EB	5	GEIL	DS	GB22GB6400C5DC	.	.	.
1G	GEIL	GL2L64M088BA30EB	5	GEIL	DS	GB24GB6400C5QC	.	.	.
1G	GEIL	Heat-Sink Package	5	GEIL	DS	GX22GB6400DC	.	.	.
1G	GEIL	Heat-Sink Package	4	GEIL	DS	GE22GB800C4DC	.	.	.

(continued on the next page)

DDR2-800 MHz capability

Size	Vendor	Chip No.	CL	Chip Brand	SS/DS	Part No.	DIMM support		
							A*	B*	C*
1G	GEIL	Heat-Sink Package	4	GEIL	DS	GE24GB800C4QC	*	*	*
1G	GEIL	Heat-Sink Package	4	GEIL	DS	GX22GB6400UDC	*	*	*
1G	GEIL	Heat-Sink Package	5	GEIL	DS	GE22GB800C5DC	*	*	*
1G	GEIL	Heat-Sink Package	5	GEIL	DS	GE24GB800C5QC	*	*	*
2G	GEIL	GL2L128M88BA25AB	4	GEIL	DS	GB24GB6400C4DC	*	*	*
2G	GEIL	GL2L128M88BA25AB	5	GEIL	DS	GB24GB6400C5DC	*	*	*
2G	GEIL	GL2L128M88BA25AB	5	GEIL	DS	GB28GB6400C5QC	*	*	*
2G	GEIL	GL2L128M88BA25AB	4	GEIL	DS	GB28GB6400C4QC	*	*	*
2G	GEIL	Heat-Sink Package	5	GEIL	DS	GX22GB6400LX	*	*	*
2G	GEIL	Heat-Sink Package	5	GEIL	DS	GX24GB6400DC	*	*	*
2G	GEIL	Heat-Sink Package	5	GEIL	DS	GE28GB800C5QC	*	*	*
2G	GEIL	Heat-Sink Package	4	GEIL	DS	GX22GB6400CUSC	*	*	*
2G	GEIL	Heat-Sink Package	4	GEIL	DS	GE24GB800C4DC	*	*	*
2G	GEIL	Heat-Sink Package	5	GEIL	DS	GE24GB800C5DC	*	*	*
1G	Super Talent	Heat-Sink Package	4	Super Talent	DS	T800UB1GC4	*	*	*
2G	G.SKILL	Heat-Sink Package	5	G.SKILL	DS	F2-6400CL5D-4GBPQ	*	*	*
4G	G.SKILL	Heat-Sink Package	5	G.SKILL	DS	F2-6400CL5Q-16GNQ	*	*	*
1G	G.SKILL	Heat-Sink Package	5	G.SKILL	DS	F2-6400CL5D-2GBNQ	*	*	*
1G	G.SKILL	Heat-Sink Package	4	G.SKILL	DS	F2-6400CL4D-2GBPK	*	*	*
1G	G.SKILL	Heat-Sink Package	4	G.SKILL	DS	F2-6400CL4D-2GBHK	*	*	*
2G	G.SKILL	Heat-Sink Package	4	G.SKILL	DS	F2-6400CL4D-4GBPK	*	*	*
512MB(Kit of 2)	G.SKILL	Heat-Sink Package	5-5-15	G.SKILL	SS	F2-6400CL5D-1GBNQ	*	*	*
2G	OCZ	Heat-Sink Package	5	OCZ	DS	OCZ2P8004GK	*	*	*
1G	OCZ	Heat-Sink Package	4	OCZ	DS	OCZ2RPR8002GK	*	*	*
1G	OCZ	Heat-Sink Package	5	OCZ	DS	OCZ2G800R22GK	*	*	*
1G	OCZ	Heat-Sink Package	4	OCZ	DS	OCZ2P800R22GK	*	*	*
1G	OCZ	Heat-Sink Package	6	OCZ	DS	OCZ2VU8004GK	*	*	*
1G	Elixir	N2TU51280BE-25C802006Z1DV	5	Elixir	DS	M2Y1G64TU8HB0B-25C	*	*	*
512MB	AENEON	AET93F25DB 0621	N/A	AENEON	SS	AET660UD00-25DB98X	*	*	*
1G	AENEON	AET93R25DB 0640	5	AENEON	DS	AET760UD00-25DB97X	*	*	*
2G	AENEON	AET03R250C 0732	5	AENEON	DS	AET860UD00-25DC08X	*	*	*
1G	AENEON	AET03R250C 0732	5	AENEON	SS	AET760UD00-25DC08X	*	*	*
512MB	MDT	18D51280D-2.50726F	5	MDT	SS	MDT 512MB	*	*	*
1G	MDT	18D51280D-2.50726E	5	MDT	DS	MDT 1024MB	*	*	*
1G	Century	HY5PS12821CFP-S5	5	Hynix	DS	28V0H8	*	*	*
1G	ASINT	DDRII1208-GE 8115	N/A	ASINT	SS	SLY2128M8-JGE	*	*	*

(continued on the next page)

DDR2-800 MHz capability

Size	Vendor	Chip No.	CL	Chip Brand	SS/DS	Part No.	DIMM support		
							A*	B*	C*
2G	ASINT	DDR11208-GE 8115	N/A	ASINT	DS	SLZ2128M8-JGE	•	•	•
1G	UMAX	U2S12D30TP-8E	N/A	UMAX	DS	D48001GP3-63BJU	•	•	•
512MB	TAKEMS	MS18T51280-2.5P0710	5	takeMS	SS	TMS51B264C081-805EP	•	•	•

DDR2-667 MHz capability

Size	Vendor	Chip No.	CL	Chip Brand	SS/DS	Part No.	DIMM support		
							A*	B*	C*
512MB	Kingston	HY5PS12821EFP-Y5	N/A	Hynix	SS	KVR667D2N5/512	•	•	•
1G	Kingston	HY5PS12821EFP-Y5	N/A	Hynix	DS	KVR667D2N5/1G	•	•	•
2G	Kingston	7RE22 D9HNL	N/A	Micron	DS	KVR667D2N5/2G	•	•	•
4G	Samsung	K4T2G084QA-HCE6	5	Samsung	DS	M378T5263AZ3-CE6	•	•	•
512MB	Qimonda	HYB18T512B00B2F3SF SS28171	5	Qimonda	SS	HY564T64000EU-3S-B2	•	•	•
1G	Qimonda	HYB18T512B00B2F3SF SS28171	5	Qimonda	DS	HY564T128020EU-3S-B2	•	•	•
1G	Corsair	MID095D62864M8CEC	N/A	Corsair	DS	VS1GB667D2	•	•	•
1G	Corsair	Heat-Sink Package	4	Corsair	DS	XMS2-5400	•	•	•
512MB	Kingmax	KKEA88B4LAUG-29DX	N/A	Kingmax	SS	KLCC28F-A8KB5	•	•	•
1G	Kingmax	KKEA88B4LAUG-29DX	N/A	Kingmax	DS	KLCD48F-A8KB5	•	•	•
512MB	Apacer	AM4B5708MIJS7E0627B	5	Apacer	SS	AU512E667C5KBGC	•	•	•
512MB	Apacer	AM4B5708GQJS7E06332F	5	Apacer	SS	AU512E667C5KBGC	•	•	•
512MB	Apacer	AM4B5708JQJS7E0751C	5	Apacer	SS	78.91G92.9K5	•	•	•
1G	Apacer	AM4B5808CQJS7E0751C	5	Apacer	SS	78.01G90.9K5	•	•	•
1G	Apacer	AM4B5708GQJS7E0636B	N/A	Apacer	DS	AU01GE667C5KBGC	•	•	•
1G	Apacer	AM4B5708MIJS7E0627B	5	Apacer	DS	AU01GE667C5KBGC	•	•	•
2G	Apacer	AM4B5808CQJS7E0749B	5	Apacer	DS	78.A1G90.9K4	•	•	•
1G	GEIL	Heat-Sink Package	3	GEIL	DS	GX21GB5300SX	•	•	•
2G	GEIL	Heat-Sink Package	5	GEIL	DS	GX24GB5300LDC	•	•	•
2G(kit of 2)	G.SKILL	D2 64M8CCF 0815 C7173S	5-5-5-15	G.SKILL	DS	F2-5400PHUJ2-2GBNT	•	•	•
4G(kit of 2)	G.SKILL	Heat-Sink Package	5-5-5-15	G.SKILL	DS	F2-5300CL5D-4GBMQ	•	•	•
1G	Transcend	E5108AJBG-6E-E	5	Elpida	DS	506010-4894	•	•	•
512MB	ADATA	AD29608A8A-3EG20813	N/A	ADATA	SS	M2OAD5G3H3160Q1C52	•	•	•
1G	ADATA	AD29608A8A-3EG80814	N/A	ADATA	DS	M2OAD5G314170Q1C58	•	•	•
2G	ADATA	AD20908A8A-3EG 30724	N/A	ADATA	DS	M2OAD5H3J41701C53	•	•	•
512MB	PSC	A3R12E3JFF717B9A00	5	PSC	SS	AL6E8E63J-6E1	•	•	•
1G	PSC	A3R12E3JFF717B9A01	5	PSC	DS	AL7E8E63J-6E1	•	•	•
1G	PSC	A3R1GE3CFF734MAA0J	5	PSC	SS	AL7E8F73C-6E1	•	•	•

(continued on the next page)

DDR2-667 MHz capability

Size	Vendor	Chip No.	CL	Chip Brand	SS/ DS	Part No.	DIMM support		
							A*	B*	C*
2G	PSC	A3R1GE3CFF733MAA00	5	PSC	DS	AL8E8F73C-6E1	*	*	*
512MB	Nanya	NT5TU64M8AE-3C	N/A	Nanya	SS	NT512T64U88A1BY-3C	*	*	*
1G	Nanya	NT5TU64M8BE-3C72155700CP	5	Nanya	DS	NT1GT64U8HB0BY-3C	*	*	*
1G	Super Talent	PG 64M8-800 0750	5	Super Talent	DS	T667UB1GV	*	*	*
512MB	Twinmos	A3R12E3GEF633ACA0Y	5	PSC	SS	8D-A3JK5MPETP	*	*	*
1G	ELIXIR	M2TU51280AE-3C717095R28F	5	ELIXIR	DS	M2Y1G64TU8HA2B-3C	*	*	*
1G	ELIXIR	N2TU51280BE-3C639009W1CF	5	ELIXIR	DS	M2Y1G64TU8HBOB-3C	*	*	*
1G	Leadmax	HY5PS12821CFP-Y5 C 702AA	N/A	Hynix	DS	LRMP512U64A8-Y5	*	*	*
512MB	MDT	18D51201D-30726E	4	MDT	DS	DDRII 512 PC667	*	*	*
1G	MDT	18D51280D-30646E	4	MDT	DS	MDT 1024MB	*	*	*
1G	AENEON	AET93R300B 0639	5	AENEON	DS	AET760UD00-30DB97X	*	*	*
2G	AENEON	AET03F30DB 0730	5	AENEON	DS	AET860UD00-30DB08X	*	*	*
512MB	AENEON	AET93R300B 0634	5	AENEON	SS	AET660UD00-30DB97X	*	*	*
1G	TAKEMS	MS18T51280-3SP0717A	5	takeMS	DS	TMS1GB264C081-665AP	*	*	*
512MB	TAKEMS	MS18T51280-3	5	takeMS	SS	TMS51B264C081-665QI	*	*	*
512MB	TAKEMS	MS18T51280-3S0627D	5	takeMS	SS	TMS51B264C081-665AP	*	*	*
1G	TAKEMS	MS18T51280-3SEA07100	5	takeMS	DS	TMS1GB264C081-665AE	*	*	*
1G	ASINT	DDR1I1208-6E 8115	N/A	ASINT	SS	SLY2128M8-J6E	*	*	*
512MB	ASINT	DDR1I6408-6E	N/A	ASINT	SS	SLX264M8-J6E	*	*	*
1G	Century	HY5PS12821AFP-Y5	N/A	Hynix	DS	CENTURY 1G	*		
1G	Century	NT5TU64M8AE-3C	N/A	Nanya	DS	CENTURY 1G		*	
512MB	Century	NT5TU64M8AE-3C	N/A	Nanya	SS	CENTURY 512MB	*	*	*
1G	UMAX	U2S12D30YP-6E	N/A	UMAX	DS	D46701GP3-63BJU	*	*	*
2G	UMAX	U2S24D30TP-6E	5	UMAX	DS	D46702GP0-73BCU	*	*	*
512MB	KINGBOX	EPD264082200-4	N/A	KINGBOX	SS	512MB 667MHz	*	*	*



If you install a DDR2-1066 memory module whose SPD is DDR2-800, ensure that you set the **DRAM Frequency** item in BIOS to [DDR2-1066MHz]. See section **4.4 Ai Tweaker Menu** for details.



SS - Single-sided / DS - Double - sided

DIMM support:

- **A***: Supports one module inserted in any slot as Single-channel memory configuration.
- **B***: Supports one pair of modules inserted into either the yellow slots or the black slots as one pair of Dual-channel memory configuration.
- **C***: Supports four modules inserted into both the yellow and black slots as two pairs of Dual-channel memory configuration.



Visit the ASUS website for the latest **DDR2-1066/800/667 MHz QVL**.

1.7.3 Installing a DIMM



Unplug the power supply before adding or removing DIMMs or other system components. Failure to do so can cause severe damage to both the motherboard and the components.

1. Unlock a DIMM socket by pressing the retaining clips outward.
2. Align a DIMM on the socket such that the notch on the DIMM matches the break on the socket.

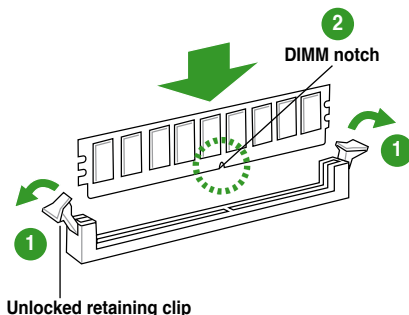

A DDR2 DIMM is keyed with a notch so that it fits in only one direction. DO NOT force a DIMM into a socket to avoid damaging the DIMM.

3. Firmly insert the DIMM into the socket until the retaining clips snap back in place and the DIMM is properly seated.

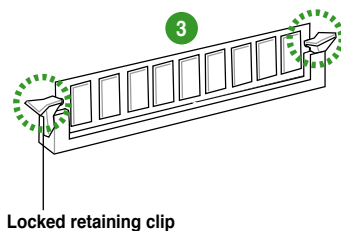

1.7.4 Removing a DIMM

To remove a DIMM:

1. Simultaneously press the retaining clips outward to unlock the DIMM.



Support the DIMM lightly with your fingers when pressing the retaining clips. The DIMM might get damaged when it flips out with extra force.

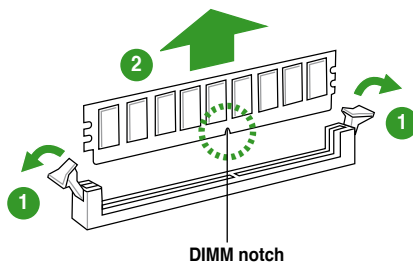

2. Remove the DIMM from the socket.

1.8 Expansion slots

In the future, you may need to install expansion cards. The following sub-sections describe the slots and the expansion cards that they support.



Ensure to unplug the power cord before adding or removing expansion cards. Failure to do so may cause you physical injury and damage motherboard components.

1.8.1 Installing an expansion card

To install an expansion card:

1. Before installing the expansion card, read the documentation that came with it and make the necessary hardware settings for the card.
2. Remove the system unit cover (if your motherboard is already installed in a chassis).
3. Remove the bracket opposite the slot that you intend to use. Keep the screw for later use.
4. Align the card connector with the slot and press firmly until the card is completely seated on the slot.
5. Secure the card to the chassis with the screw you removed earlier.
6. Replace the system cover.

1.8.2 Configuring an expansion card

After installing the expansion card, configure it by adjusting the software settings.

1. Turn on the system and change the necessary BIOS settings, if any. See Chapter 4 for information on BIOS setup.
2. Assign an IRQ to the card. Refer to the tables on the next page.
3. Install the software drivers for the expansion card.



When using PCI cards on shared slots, ensure that the drivers support “Share IRQ” or that the cards do not need IRQ assignments. Otherwise, conflicts will arise between the two PCI groups, making the system unstable and the card inoperable. Refer to the table on the next page for details.

1.8.3 Interrupt assignments

IRQ	Standard function
0	System timer
1	Standard 101/102-key or Microsoft natural keyboard
2	Free
3	Free
4	Communications Port (COM1)*
5	Free
6	Standard floppy
7	(Free)
8	System CMOS/Real Time Clock
9	Microsoft ACPI-Compliant system
10	Free
11	(Free)
12	Microsoft PS/2 port mouse
13	Numeric data processor
14	Free
15	Intel® ICH10 Family SM bus controller-3A30

* These IRQs are usually available for PCI devices.

IRQ assignments for this motherboard

	A	B	C	D	E	F	G	H
PCIEx1_1 slot	shared	shared	shared	shared	-	-	-	-
PCIEx1_2 slot	shared	shared	shared	shared	-	-	-	-
PCIEx16 slot	shared	shared	shared	shared	-	-	-	-
USB 1.1 controller 1	-	-	-	-	-	-	-	shared
USB 1.1 controller 2	-	-	-	shared	-	-	-	-
USB 1.1 controller 3	-	-	shared	-	-	-	-	-
USB 1.1 controller 4	shared	-	-	-	-	-	-	-
USB 1.1 controller 5	shared	-	-	-	-	-	-	-
USB 1.1 controller 6	-	-	-	-	-	shared	-	-
USB 1.1 controller 7	-	-	shared	-	-	-	-	-
USB 2.0 controller 1	-	-	-	-	-	-	-	shared
USB 2.0 controller 2	-	-	shared	-	-	-	-	-
IDE port	shared	-	-	-	-	-	-	-
HD audio	-	-	-	-	-	-	shared	-
LAN	-	shared	-	-	-	-	-	-
Onchip SATA 1	-	-	shared	shared	-	-	-	-
Onchip SATA 2	-	-	shared	-	-	-	-	-
PCI card 1	shared	shared	shared	shared	-	-	-	-
PCI card 2	shared	shared	shared	shared	-	-	-	-
PCI card 3	shared	shared	shared	shared	-	-	-	-

1.8.4 PCI slots

The PCI slots support cards such as a LAN card, SCSI card, USB card, and other cards that comply with PCI specifications. Refer to the figure below for the location of the slots.

1.8.5 PCI Express x1 slots

This motherboard supports PCI Express x1 network cards, SCSI cards and other cards that comply with the PCI Express specifications. Refer to the figure below for the location of the slots.

1.8.6 PCI Express 2.0 x16 slot

This motherboard has one PCI Express 2.0 x16 slot that supports PCI Express 2.0 x16 graphic cards complying with the PCI Express specifications. Refer to the figure below for the location of the slots.

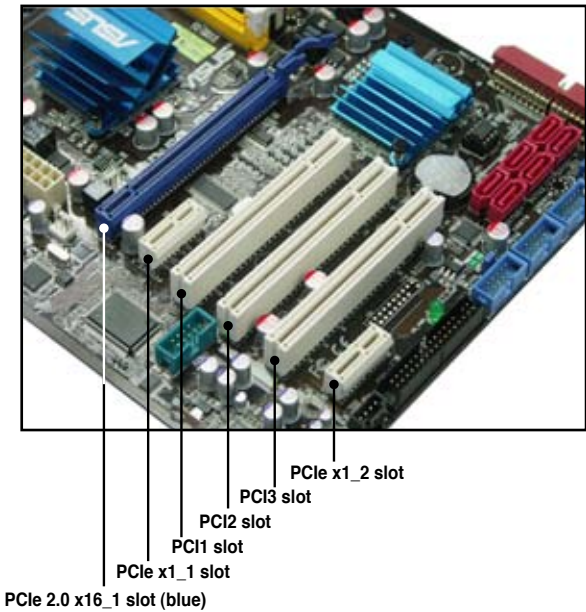

1.9 Jumpers

1. Clear RTC RAM (3-pin CLRRTC)

This jumper allows you to clear the Real Time Clock (RTC) RAM in CMOS. You can clear the CMOS memory of date, time, and system setup parameters by erasing the CMOS RTC RAM data. The onboard button cell battery powers the RAM data in CMOS, which include system setup information such as system passwords.

To erase the RTC RAM:

1. Turn OFF the computer and unplug the power cord.
2. Move the jumper cap from pins 1–2 (default) to pins 2–3. Keep the cap on pins 2–3 for about 5–10 seconds, then move the cap back to pins 1–2.
3. Plug the power cord and turn ON the computer.
4. Hold down the key during the boot process and enter BIOS setup to re-enter data.



Except when clearing the RTC RAM, never remove the cap on CLRRTC jumper default position. Removing the cap will cause system boot failure!

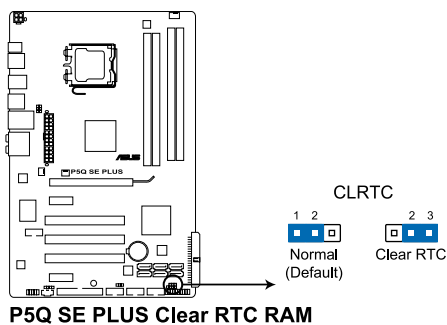

- If the steps above do not help, remove the onboard battery and move the jumper again to clear the CMOS RTC RAM data. After the CMOS clearance, reinstall the battery.
- You do not need to clear the RTC when the system hangs due to overclocking. For system failure due to overclocking, use the C.P.R. (CPU Parameter Recall) feature. Shut down and reboot the system so the BIOS can automatically reset parameter settings to default values.
- Due to the chipset limitation, AC power off is required prior using C.P.R. function. You must turn off and on the power supply or unplug and plug the power cord before reboot the system.

2. Keyboard power (3-pin KBPWR)

This jumper allows you to enable or disable the keyboard wake-up feature. When you set this jumper to pins 2–3 (+5VSB), you can wake up the computer by pressing a key on the keyboard (the default is the Space Bar)s. This feature requires an ATX power supply that can supply at least 1A on the +5VSB lead, and a corresponding setting in the BIOS.

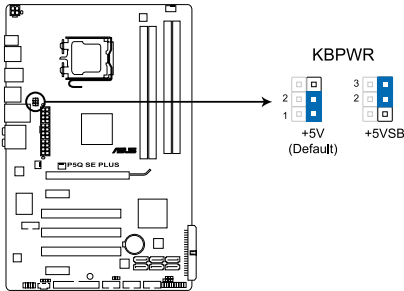

P5Q SE PLUS Keyboard power setting

3. USB device wake-up (3-pin USBPW1-5, 3-pin USBPW6-11)

Set these jumpers to +5V to wake up the computer from S1 sleep mode (CPU stopped, DRAM refreshed, system running in low power mode) using the connected USB devices. Set to +5VSB to wake up from S3 and S4 sleep modes (no power to CPU, DRAM in slow refresh, power supply in reduced power mode).

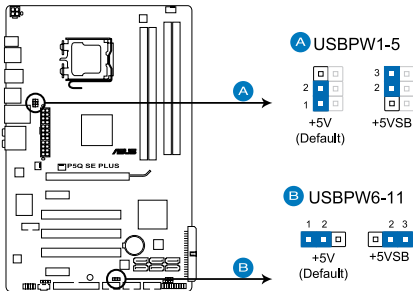

P5Q SE PLUS USB device wake-up



- The USB device wake-up feature requires a power supply that can provide 500mA on the +5VSB lead for each USB port; otherwise, the system would not power up.
- The total current consumed must NOT exceed the power supply capability (+5VSB) whether under normal condition or in sleep mode.

1.10 Connectors

1.10.1 Rear panel connectors

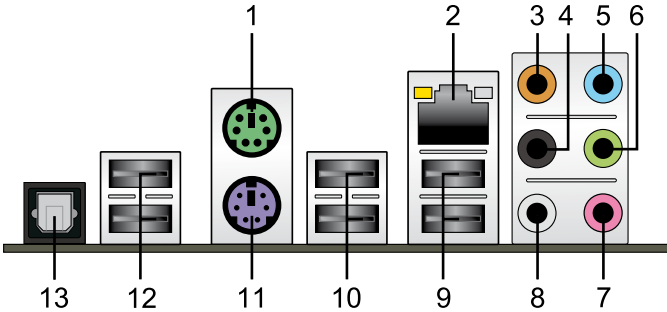

1. **PS/2 mouse port (green).** This port is for a PS/2 mouse.
2. **LAN (RJ-45) port.** Supported by Gigabit LAN controller, this port allows Gigabit connection to a Local Area Network (LAN) through a network hub. Refer to the table below for the LAN port LED indications.

LAN port LED indications

Activity/Link LED		Speed LED	
Status	Description	Status	Description
OFF	No link	OFF	10 Mbps connection
ORANGE	Linked	ORANGE	100 Mbps connection
BLINKING	Data activity	GREEN	1 Gbps connection

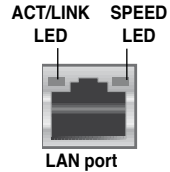

3. **Center/Subwoofer port (orange).** This port connects the center/subwoofer speakers.
4. **Rear Speaker Out port (black).** This port connects the rear speakers in a 4-channel, 6-channel, or 8-channel audio configuration.
5. **Line In port (light blue).** This port connects the tape, CD, DVD player, or other audio sources.
6. **Line Out port (lime).** This port connects a headphone or a speaker. In 4-channel, 6-channel, and 8-channel configuration, the function of this port becomes Front Speaker Out.
7. **Microphone port (pink).** This port connects a microphone.
8. **Side Speaker Out port (gray).** This port connects the side speakers in an 8-channel audio configuration.



Refer to the audio configuration table on the next page for the function of the audio ports in 2, 4, 6, or 8-channel configuration.

Audio 2, 4, 6, or 8-channel configuration

Port	Headset 2-channel	4-channel	6-channel	8-channel
Light Blue	Line In	Line In	Line In	Line In
Lime	Line Out	Front Speaker Out	Front Speaker Out	Front Speaker Out
Pink	Mic In	Mic In	Mic In	Mic In
Orange	–	–	Center/Subwoofer	Center/Subwoofer
Black	–	Rear Speaker Out	Rear Speaker Ou	Rear Speaker Out
Gray	–	–	–	Side Speaker Out

- USB 2.0 ports 1 and 2.** These two 4-pin Universal Serial Bus (USB) ports are available for connecting USB 2.0 devices.
- USB 2.0 ports 3 and 4.** These two 4-pin Universal Serial Bus (USB) ports are available for connecting USB 2.0 devices.
- PS/2 keyboard port (purple).** This port is for a PS/2 keyboard.
- USB 2.0 ports 5 and 6.** These two 4-pin Universal Serial Bus (USB) ports are available for connecting USB 2.0 devices.
- Optical S/PDIF Out port.** This port connects an external audio output device via a optical S/PDIF cable.

1.10.2 Internal connectors

1. Floppy disk drive connector (34-1 pin FLOPPY)

This connector is for the provided floppy disk drive (FDD) signal cable. Insert one end of the cable to this connector, then connect the other end to the signal connector at the back of the floppy disk drive.



Pin 5 on the connector is removed to prevent incorrect cable connection when using a FDD cable with a covered Pin 5.

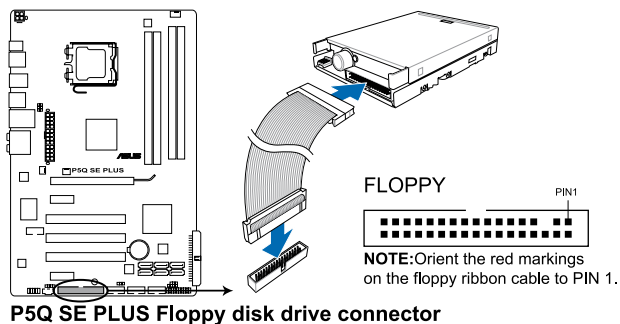

2. IDE connector (40-1 pin PRI_EIDE)

The onboard IDE connector is for the Ultra DMA 133/100/66 signal cable. There are three connectors on each Ultra DMA 133/100/66 signal cable: blue, black, and gray. Connect the blue connector to the motherboard's IDE connector, then select one of the following modes to configure your device.

	Drive jumper setting	Mode of device(s)	Cable connector
Single device	Cable-Select or Master	-	Black
Two devices	Cable-Select	Master	Black
		Slave	Gray
	Master	Master	Black or gray
	Slave	Slave	



- Pin 20 on the IDE connector is removed to match the covered hole on the Ultra DMA cable connector. This prevents incorrect insertion when you connect the IDE cable.
- Use the 80-conductor IDE cable for Ultra DMA 133/100/66 IDE devices.



If any device jumper is set as "Cable-Select," ensure that all other device jumpers have the same setting.

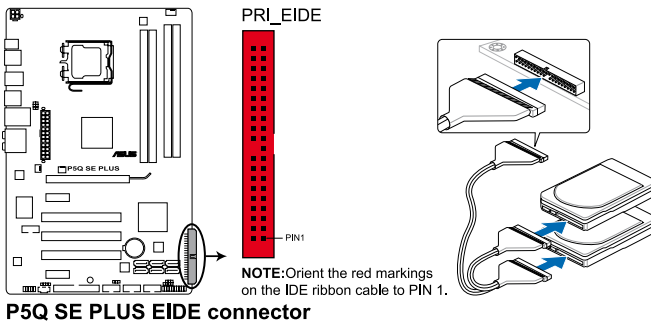

3. ICH10 Serial ATA connectors (7-pin SATA1-6)

These connectors are for the Serial ATA signal cables for Serial ATA hard disk drives.

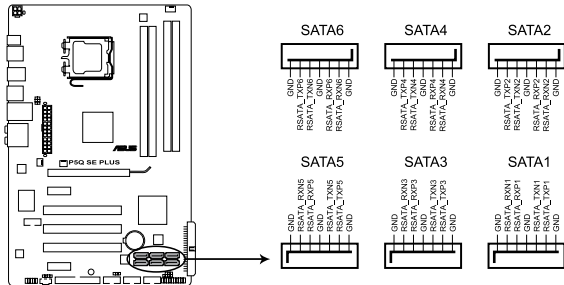

P5Q SE PLUS SATA connectors (Intel® ICH10)



Connect the right-angle side of SATA signal cable to SATA device. Or you may connect the right-angle side of SATA cable to the onboard SATA port to avoid mechanical conflict with huge graphics cards.

right angle side

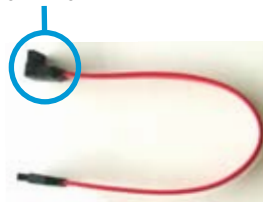

4. Digital audio connector (4-1 pin SPDIF_OUT)

This connector is for an additional Sony/Philips Digital Interface (S/PDIF) port(s). Connect the S/PDIF Out module cable to this connector, then install the module to a slot opening at the back of the system chassis.

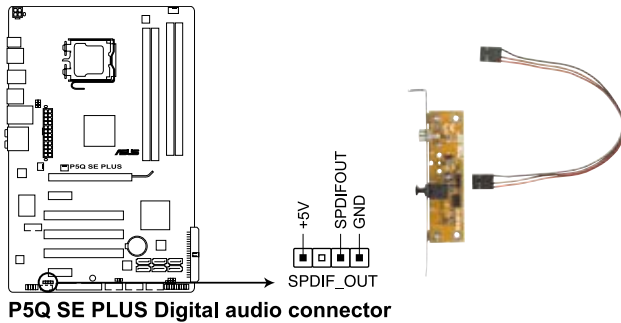

P5Q SE PLUS Digital audio connector



The S/PDIF module is purchased separately.

5. USB connectors (10-1 pin USB78, USB 910, USB1112)

These connectors are for USB 2.0 ports. Connect the USB module cable to any of these connectors, then install the module to a slot opening at the back of the system chassis. These USB connectors comply with USB 2.0 specification that supports up to 480 Mbps connection speed.

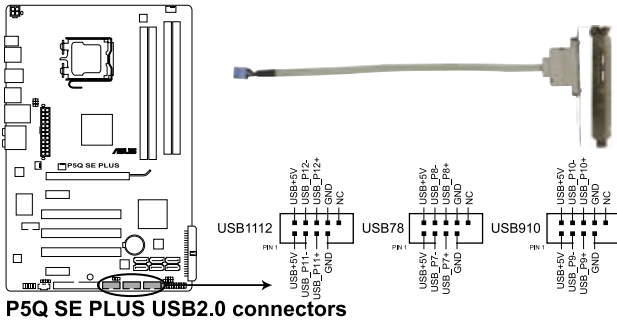

You can connect the front panel USB cable to the ASUS Q-Connector (USB, blue) first, and then install the Q-Connector (USB) to the USB connector onboard if your chassis supports front panel USB ports.



The USB module cable is purchased separately.

6. Optical drive audio connector (4-pin CD)

These connectors allow you to receive stereo audio input from sound sources such as a CD-ROM, TV tuner, or MPEG card.

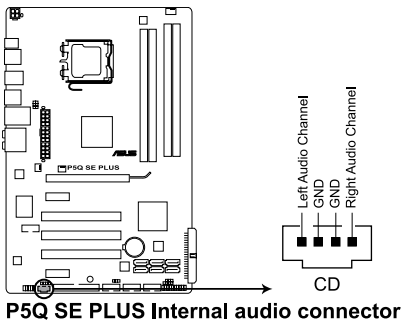

7. CPU, chassis, and power fan connectors (4-pin CPU_FAN, 3-pin CHA_FAN, 3-pin PWR_FAN)

The fan connectors support cooling fans of 350 mA~2000 mA (24 W max.) or a total of 1 A~7 A (84 W max.) at +12V. Connect the fan cables to the fan connectors on the motherboard, making sure that the black wire of each cable matches the ground pin of the connector.



Do not forget to connect the fan cables to the fan connectors. Insufficient air flow inside the system may damage the motherboard components. These are not jumpers! Do not place jumper caps on the fan connectors!

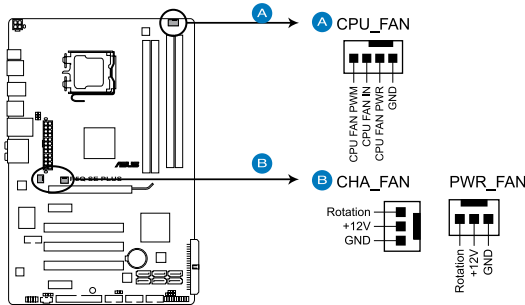

P5Q SE PLUS Fan connectors



Only the CPU_FAN and CHA_FAN connector support the ASUS Q-FAN feature.

8. Serial port connector (10-1 pin COM1)

This connector is for a serial (COM) port. Connect the serial port module cable to this connector, then install the module to a slot opening at the back of the system chassis.

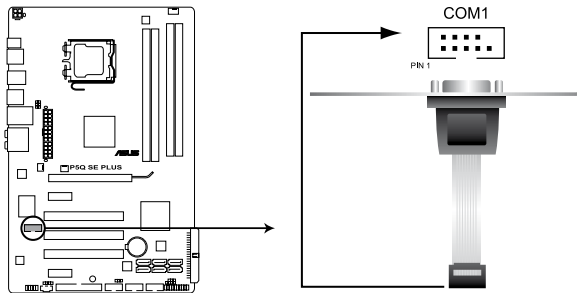

P5Q SE PLUS Serial port (COM1) connector



The serial port module is purchased separately.

9. Chassis intrusion connector (4-1 pin CHASSIS)

This connector is for a chassis-mounted intrusion detection sensor or switch. Connect one end of the chassis intrusion sensor or switch cable to this connector. The chassis intrusion sensor or switch sends a high-level signal to this connector when a chassis component is removed or replaced. The signal is then generated as a chassis intrusion event.

By default, the pin labeled “Chassis Signal” and “Ground” are shorted with a jumper cap. Remove the jumper caps only when you intend to use the chassis intrusion detection feature.

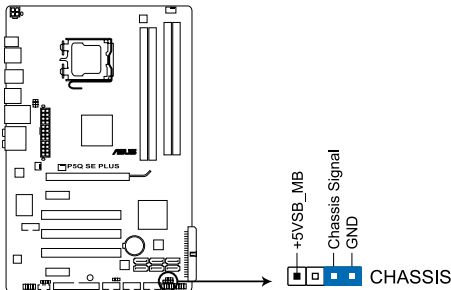

P5Q SE PLUS Chassis intrusion connector

10. Front panel audio connector (10-1 pin AAFP)

This connector is for a chassis-mounted front panel audio I/O module that supports either HD Audio or legacy AC'97 audio standard. Connect one end of the front panel audio I/O module cable to this connector.

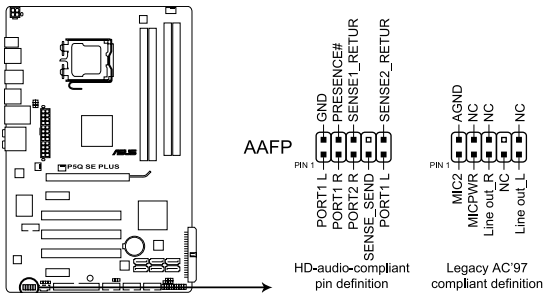

P5Q SE PLUS Analog front panel connector



- We recommend that you connect a high-definition front panel audio module to this connector to avail of the motherboard's high-definition audio capability.
- If you want to connect a high-definition front panel audio module to this connector, set the **Front Panel Type** item in the BIOS setup to **[HD Audio]**; if you want to connect an AC'97 front panel audio module to this connector, set the item to **[AC'97]**. By default, this connector is set to **[HD Audio]**. See section 2.5.3 **Onboard Devices Configuration** for details.

11. ATX power connectors (24-pin EATXPWR, 4-pin ATX12V)

These connectors are for ATX power supply plugs. The power supply plugs are designed to fit these connectors in only one orientation. Find the proper orientation and push down firmly until the connectors completely fit.

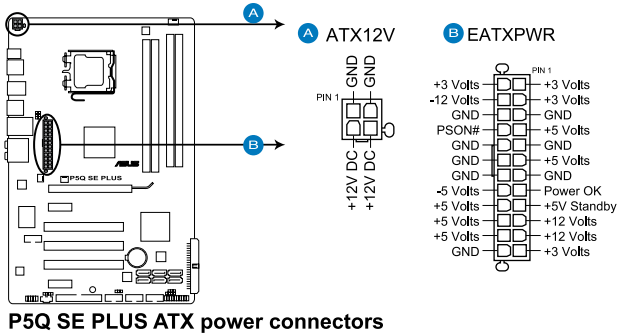

- For a fully configured system, we recommend that you use a power supply unit (PSU) that complies with ATX 12V Specification 2.0 (or later version) and provides a minimum power of 400 W.
- Do not forget to connect the 4-pin EATX12V power plug; otherwise, the system will not boot.
- Use of a PSU with a higher power output is recommended when configuring a system with more power-consuming devices. The system may become unstable or may not boot up if the power is inadequate.
- If you are uncertain about the minimum power supply requirement for your system, refer to the **Recommended Power Supply Wattage Calculator** at <http://support.asus.com/PowerSupplyCalculator/PSCalculator.aspx?SLanguage=en-us> for details.

12. System panel connector (20-8 pin PANEL)

This connector supports several chassis-mounted functions.

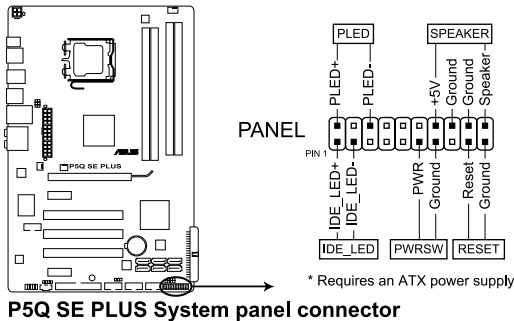

- **System power LED (2-pin PLED)**
This 2-pin connector is for the system power LED. Connect the chassis power LED cable to this connector. The system power LED lights up when you turn on the system power, and blinks when the system is in sleep mode.
- **Hard disk drive activity LED (2-pin IDE_LED)**
This 2-pin connector is for the HDD Activity LED. Connect the HDD Activity LED cable to this connector. The IDE LED lights up or flashes when data is read from or written to the HDD.
- **System warning speaker (4-pin SPEAKER)**
This 4-pin connector is for the chassis-mounted system warning speaker. The speaker allows you to hear system beeps and warnings.
- **ATX power button/soft-off button (2-pin PWRSW)**
This connector is for the system power button. Pressing the power button turns the system on or puts the system in sleep or soft-off mode depending on the BIOS settings. Pressing the power switch for more than four seconds while the system is ON turns the system OFF.
- **Reset button (2-pin RESET)**
This 2-pin connector is for the chassis-mounted reset button for system reboot without turning off the system power.

ASUS Q-Connector (system panel)

You can use the ASUS Q-Connector to connect/disconnect chassis front panel cables in a few steps. Refer to the instructions below to install the ASUS Q-Connector.

1. Connect the front panel cables to the ASUS Q-Connector.

Refer to the labels on the Q-Connector to know the detailed pin definitions, then match them to the respective front panel cable labels.

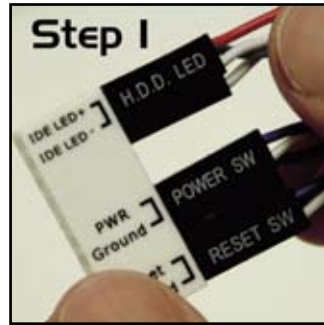

2. Install the ASUS Q-Connector to the system panel connector, ensuring the orientation matches the labels on the motherboard.

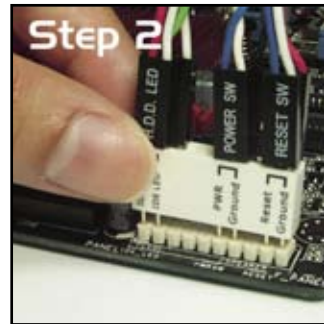

Enable the front panel functions.
The figure shows the Q-Connector properly installed on the motherboard.

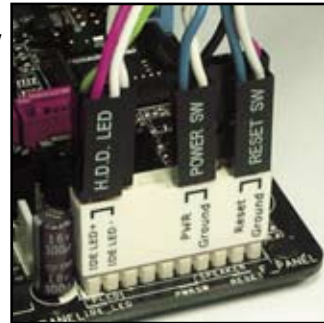

1.11 Starting up for the first time

1. After making all the connections, replace the system case cover.
2. Be sure that all switches are off.
3. Connect the power cord to the power connector at the back of the system chassis.
4. Connect the power cord to a power outlet that is equipped with a surge protector.
5. Turn on the devices in the following order:
 - a. Monitor
 - b. External SCSI devices (starting with the last device on the chain)
 - c. System power
6. After applying power, the system power LED on the system front panel case lights up. For systems with ATX power supplies, the system LED lights up when you press the ATX power button. If your monitor complies with “green” standards or if it has a “power standby” feature, the monitor LED may light up or switch between orange and green after the system LED turns on.

The system then runs the power-on self tests or POST. While the tests are running, the BIOS beeps (see BIOS beep codes table below) or additional messages appear on the screen. If you do not see anything within 30 seconds from the time you turned on the power, the system may have failed a power-on test. Check the jumper settings and connections or call your retailer for assistance.

BIOS Beep	Description
One short beep	VGA detected Quick boot set to disabled No keyboard detected
One continuous beep followed by two short beeps then a pause (repeated)	No memory detected
One continuous beep followed by three short beeps	No VGA detected
One continuous beep followed by four short beeps	Hardware component failure

7. At power on, hold down the <Delete> key to enter the BIOS Setup. Follow the instructions in Chapter 3.

1.12 Turning off the computer

1.12.1 Using the OS shut down function

If you are using Windows® XP:

1. Click the Start button then select Turn Off Computer.
2. Click the Turn Off button to shut down the computer.
3. The power supply should turn off after Windows® shuts down.

If you are using Windows® Vista:

1. Click the Start button then select ShutDown.
2. The power supply should turn off after Windows® shuts down.

1.12.2 Using the dual function power switch

While the system is ON, pressing the power switch for less than four seconds puts the system to sleep mode or to soft-off mode, depending on the BIOS setting. Pressing the power switch for more than four seconds lets the system enter the soft-off mode regardless of the BIOS setting. Refer to section **2.6 Power Menu** in Chapter 2 for details.

This chapter tells how to change the system settings through the BIOS Setup menus. Detailed descriptions of the BIOS parameters are also provided.

BIOS setup **2**

2.1 Managing and updating your BIOS

The following utilities allow you to manage and update the motherboard Basic Input/Output System (BIOS) setup.

1. **ASUS Update:** Updates the BIOS in Windows® environment.
2. **ASUS EZ Flash 2:** Updates the BIOS using a floppy disk or USB flash disk.
3. **ASUS AFUDOS:** Updates the BIOS using a bootable floppy disk.
4. **ASUS CrashFree BIOS 3:** Updates the BIOS using a bootable floppy disk, USB flash disk or the motherboard support DVD when the BIOS file fails or gets corrupted.

Refer to the corresponding sections for details on these utilities.



Save a copy of the original motherboard BIOS file to a bootable floppy disk or USB flash disk in case you need to restore the BIOS in the future. Copy the original motherboard BIOS using the ASUS Update or AFUDOS utilities.

2.1.1 ASUS Update utility

The ASUS Update is a utility that allows you to manage, save, and update the motherboard BIOS in Windows® environment. The ASUS Update utility allows you to:

- Save the current BIOS file
- Download the latest BIOS file from the Internet
- Update the BIOS from an updated BIOS file
- Update the BIOS directly from the Internet, and
- View the BIOS version information.

This utility is available in the support DVD that comes with the motherboard package.



ASUS Update requires an Internet connection either through a network or an Internet Service Provider (ISP).

Installing ASUS Update

To install ASUS Update:

1. Place the support DVD in the optical drive. The Drivers menu appears.
2. Click the **Utilities** tab, then click **Install ASUS Update**.
3. The ASUS Update utility is copied to your system.



Quit all Windows® applications before you update the BIOS using this utility.

Updating the BIOS through the Internet

To update the BIOS through the Internet:

1. Launch the ASUS Update utility from the Windows® desktop by clicking **Start > Programs > ASUS > ASUSUpdate > ASUSUpdate**. The ASUS Update main window appears.

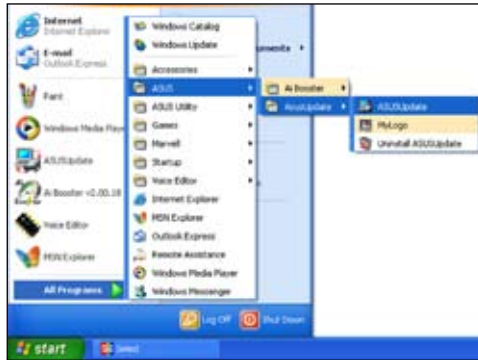

2. Select **Update BIOS** from the Internet option from the drop-down menu, then click **Next**.
3. Select the ASUS FTP site nearest you to avoid network traffic, or click **Auto Select**. Click **Next**.

- From the FTP site, select the BIOS version that you wish to download. Click **Next**.
- Follow the screen instructions to complete the update process.



The ASUS Update utility is capable of updating itself through the Internet. Always update the utility to avail all its features.



Updating the BIOS through a BIOS file

To update the BIOS through a BIOS file:

- Launch the ASUS Update utility from the Windows® desktop by clicking **Start > Programs > ASUS > ASUSUpdate > ASUSUpdate**. The ASUS Update main window appears.
- Select Update BIOS from a file option from the drop-down menu, then click **Next**.



- Locate the BIOS file from the Open window, then click **Open**.
- Follow the screen instructions to complete the update process.

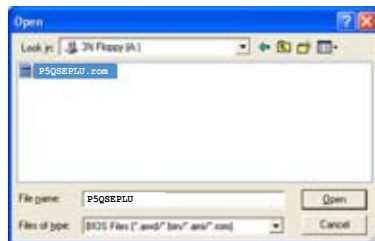

2.1.2 Creating a bootable floppy disk

1. Do either one of the following to create a bootable floppy disk.

DOS environment

- a. Insert a 1.44MB floppy disk into the drive.
- b. At the DOS prompt, type `format a: /s` then press <Enter>.

Windows® XP environment

- a. Insert a 1.44 MB floppy disk to the floppy disk drive.
- b. Click **Start** from the Windows® desktop, then select **My Computer**.
- c. Select the 3 1/2 Floppy Drive icon.
- d. Click File from the menu, then select **Format**. A **Format 3 1/2 Floppy Disk** window appears.
- e. Select **Create an MS-DOS startup disk** from the format options field, then click **Start**.

Windows® Vista environment

- a. Insert a formatted, high density 1.44 MB floppy disk to the floppy disk drive.
 - b. Click  from the Windows® desktop, then select **Computer**.
 - c. Right-click **Floppy Disk Drive** then click **Format** to display the **Format 3 1/2 Floppy** dialog box.
 - d. Select the **Create an MS-DOS startup disk** check box.
 - e. Click **Start**.
2. Copy the original or the latest motherboard BIOS file to the bootable floppy disk.

2.1.3 ASUS EZ Flash 2 utility

The ASUS EZ Flash 2 feature allows you to update the BIOS without having to go through the long process of booting from a floppy disk and using a DOS-based utility. The EZ Flash 2 utility is built-in the BIOS chip so it is accessible by pressing <Alt> + <F2> during the Power-On Self Tests (POST).

To update the BIOS using EZ Flash 2:

1. Visit the ASUS website (www.asus.com) to download the latest BIOS file for the motherboard.
2. Save the BIOS file to a floppy disk or a USB flash disk, then restart the system.
3. You can launch the EZ Flash 2 by two methods.

- (1) Insert the floppy disk / USB flash disk that contains the BIOS file to the floppy disk drive or the USB port.

Press <Alt> + <F2> during POST to display the following.

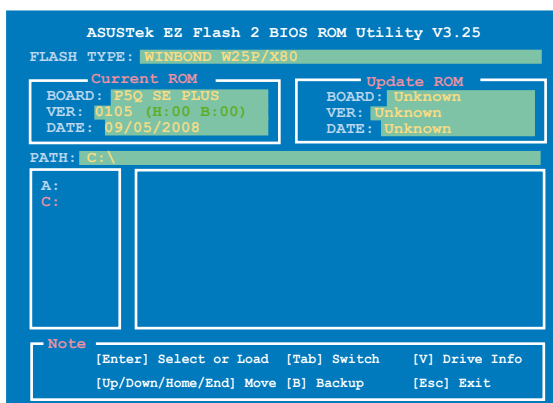

- (2) Enter BIOS setup program. Go to the **Tools** menu to select **EZ Flash2** and press <Enter> to enable it.

You can switch between drives by pressing <Tab> before the correct file is found. Then press <Enter>.

4. When the correct BIOS file is found, EZ Flash 2 performs the BIOS update process and automatically reboots the system when done.



- This function can support devices such as USB flash disk, or floppy disk with **FAT 32/16** format and single partition only.
- Do not shut down or reset the system while updating the BIOS to prevent system boot failure!

2.1.4 AFUDOS utility

The AFUDOS utility allows you to update the BIOS file in DOS environment using a bootable floppy disk with the updated BIOS file. This utility also allows you to copy the current BIOS file that you can use as backup when the BIOS fails or gets corrupted during the updating process.

Copying the current BIOS

To copy the current BIOS file using the AFUDOS utility:



- Ensure that the floppy disk is not write-protected and has at least 1024KB free space to save the file.
- The succeeding BIOS screens are for reference only. The actual BIOS screen displays may not be same as shown.

1. Copy the AFUDOS utility (afudos.exe) from the motherboard support DVD to the bootable floppy disk you created earlier.
2. Boot the system in DOS mode, then at the prompt type:

```
afudos /o[filename]
```

where the [filename] is any user-assigned filename not more than eight alphanumeric characters for the main filename and three alphanumeric characters for the extension name.

```
A:\>afudos /oOLDBIOS1.rom
```

Main filename Extension name

3. Press <Enter>. The utility copies the current BIOS file to the floppy disk.

```
A:\>afudos /oOLDBIOS1.rom
AMI Firmware Update Utility - Version 1.19 (ASUS V2.07 (03.11.24BB))
Copyright (C) 2002 American Megatrends, Inc. All rights reserved.
Reading flash ..... done
Write to file..... ok
A:\>
```

The utility returns to the DOS prompt after copying the current BIOS file.

Updating the BIOS file

To update the BIOS file using the AFUDOS utility:

1. Visit the ASUS website (www.asus.com) and download the latest BIOS file for the motherboard. Save the BIOS file to a bootable floppy disk.



Write the BIOS filename on a piece of paper. You need to type the exact BIOS filename at the DOS prompt.

2. Copy the AFUDOS utility (afudos.exe) from the motherboard support DVD to the bootable floppy disk you created earlier.
3. Boot the system in DOS mode, then at the prompt type:
afudos /i [filename]

where [filename] is the latest or the original BIOS file on the bootable floppy disk.

```
A:\>afudos /iP5QSEPLU.ROM
```

4. The utility verifies the file and starts updating the BIOS.

```
A:\>afudos /iP5QSEPLU.ROM
AMI Firmware Update Utility - Version 1.19 (ASUS V2.07(03.11.24BB))
Copyright (C) 2002 American Megatrends, Inc. All rights reserved.

WARNING!! Do not turn off power during flash BIOS
Reading file ..... done
Reading flash ..... done

Advance Check .....
Erasing flash ..... done
Writing flash ..... 0x0008cc00 (9%)
```



Do not shut down or reset the system while updating the BIOS to prevent system boot failure!

5. The utility returns to the DOS prompt after the BIOS update process is completed. Reboot the system from the hard disk drive.

```
A:\>afudos /iP5QSEPLU.ROM
AMI Firmware Update Utility - Version 1.19 (ASUS V2.07(03.11.24BB))
Copyright (C) 2002 American Megatrends, Inc. All rights reserved.

WARNING!! Do not turn off power during flash BIOS
Reading file ..... done
Reading flash ..... done

Advance Check .....
Erasing flash ..... done
Writing flash ..... done
Verifying flash .... done

Please restart your computer

A:\>
```

2.1.5 ASUS CrashFree BIOS 3 utility

The ASUS CrashFree BIOS 3 is an auto recovery tool that allows you to restore the BIOS file when it fails or gets corrupted during the updating process. You can update a corrupted BIOS file using the motherboard support DVD or a USB flash disk that contains the updated BIOS file.



- Prepare the motherboard support DVD or the USB flash disk containing the updated motherboard BIOS before using this utility.
- For the P5Q SE Plus motherboard, this utility will not function when you use a PATA optical drive.
- Always connect the SATA cable to the SATA1 / SATA 2 connector; otherwise, the utility will not function.

Recovering the BIOS from the support DVD

To recover the BIOS from the support DVD:

1. Turn on the system.
2. Insert the motherboard support DVD to the optical drive.
3. The utility displays the following message and automatically checks the DVD for the BIOS file.

```
Bad BIOS checksum. Starting BIOS recovery...
Checking for floppy...
```

When found, the utility reads the BIOS file and starts flashing the corrupted BIOS file.

```
Bad BIOS checksum. Starting BIOS recovery...
Checking for floppy...
Floppy found!
Reading file "P5QSEPLU.ROM". Completed.
Start flashing...
```

4. Restart the system after the utility completes the updating process.

Recovering the BIOS from a USB flash disk

To recover the BIOS from a USB flash disk:

1. Insert a USB flash disk that contains BIOS file to the USB port.
2. Turn on the system.
3. The utility will automatically checks the devices for the BIOS file. When found, the utility reads the BIOS file and starts flashing the corrupted BIOS file.
4. Restart the system after the utility completes the updating process.



- Only the USB flash disk with FAT 32/16 format and single partition can support ASUS CrashFree BIOS 3. The device size should be smaller than 8GB.
- DO NOT shut down or reset the system while updating the BIOS! Doing so can cause system boot failure!

2.2 BIOS setup program

This motherboard supports a programmable Serial Peripheral Interface (SPI) chip that you can update using the provided utility described in section “2.1 Managing and updating your BIOS”.

Use the BIOS Setup program when you are installing a motherboard, reconfiguring your system, or prompted to “Run Setup”. This section explains how to configure your system using this utility.

Even if you are not prompted to use the Setup program, you can change the configuration of your computer in the future. For example, you can enable the security password feature or change the power management settings. This requires you to reconfigure your system using the BIOS Setup program so that the computer can recognize these changes and record them in the CMOS RAM of the SPI chip.

The SPI chip on the motherboard stores the Setup utility. When you start up the computer, the system provides you with the opportunity to run this program. Press during the Power-On Self-Test (POST) to enter the Setup utility. Otherwise, POST continues with its test routines.

If you wish to enter Setup after POST, reboot the system by doing any of the following procedures:

- Restart using the OS standard shut-down procedure.
- Press <Ctrl>+<Alt>+ simultaneously.
- Press the reset button on the system chassis.
- Press the power button to turn the system off then back on.



Using the **power button**, **reset button**, or the **<Ctrl>+<Alt>+** keys to force reset from a running operating system can cause damage to your data or system. We recommend to always shut-down the system properly from the operating system.

The Setup program is designed to make it as easy to use as possible. Being a menu-driven program, it lets you scroll through the various sub-menus and make your selections from the available options using the navigation keys.



-
- The default BIOS settings for this motherboard apply for most conditions to ensure optimum performance. If the system becomes unstable after changing any BIOS settings, load the default settings to ensure system compatibility and stability. Select the **Load Default Settings** item under the **Exit Menu**. See section “2.9 Exit Menu”.
 - The BIOS setup screens shown in this section are for reference purposes only, and may not exactly match what you see on your screen.
 - Visit the ASUS website (www.asus.com) to download the latest BIOS file for this motherboard.
-

2.2.1 BIOS menu screen

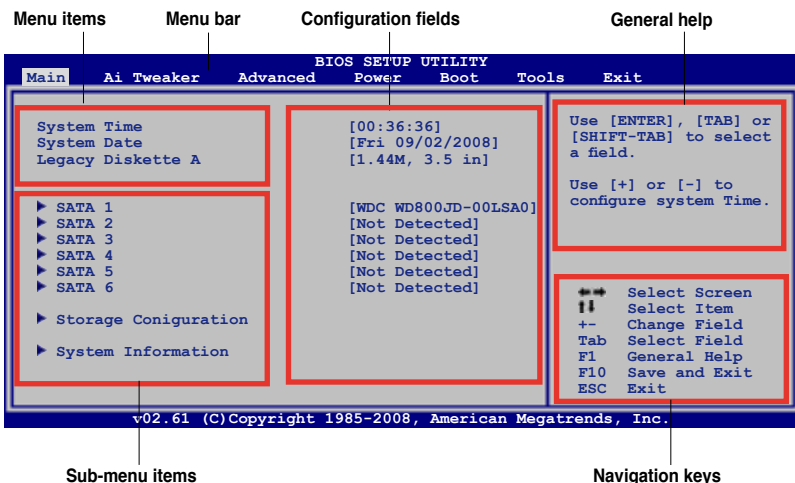

2.2.2 Menu bar

The menu bar on top of the screen has the following main items:

- Main** For changing the basic system configuration
- Ai Tweaker** For changing system performance settings
- Advanced** For changing the advanced system settings
- Power** For changing the advanced power management (APM) configuration
- Boot** For changing the system boot configuration
- Tools** For Configuring options for special functions
- Exit** For selecting the exit options and loading default settings.

To select an item on the menu bar, press the right or left arrow key on the keyboard until the desired item is highlighted.

2.2.3 Navigation keys

At the bottom right corner of a menu screen are the navigation keys for that particular menu. Use the navigation keys to select items in the menu and change the settings.



Some of the navigation keys differ from one screen to another.

2.3 Main menu

When you enter the BIOS Setup program, the Main menu screen appears, giving you an overview of the basic system information.



Refer to section **2.2.1 BIOS menu screen** for information on the menu screen items and how to navigate through them.

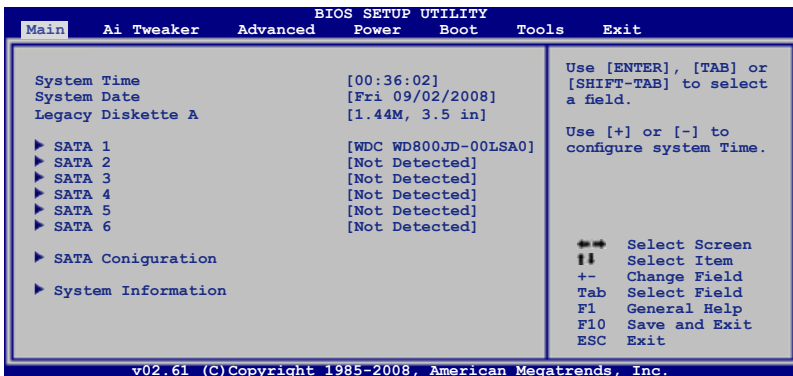

2.3.1 System Time [xx:xx:xx]

Allows you to set the system time.

2.3.2 System Date [Day xx/xx/xxxx]

Allows you to set the system date.

2.3.3 Legacy Diskette A [1.44M, 3.5 in.]

Sets the type of floppy drive installed.

Configuration options: [Disabled] [720K, 3.5 in.] [1.44M, 3.5 in.]

2.3.4 SATA 1-6

While entering Setup, the BIOS automatically detects the presence of IDE devices. There is a separate sub-menu for each IDE device. Select a device item then press <Enter> to display the IDE device information.

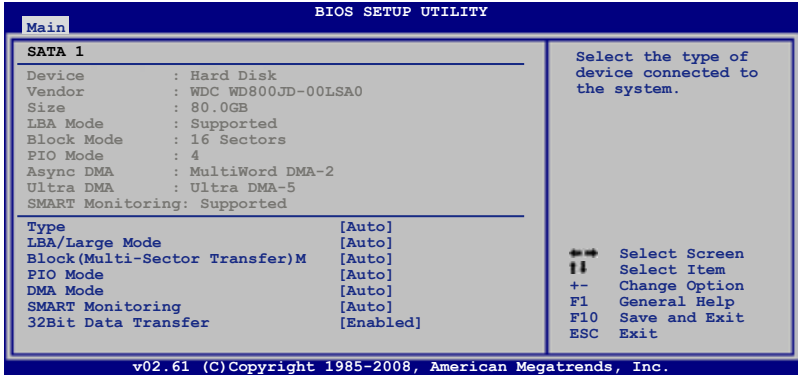

The BIOS automatically detects the values opposite the dimmed items (Device, Vendor, Size, LBA Mode, Block Mode, PIO Mode, Async DMA, Ultra DMA, and SMART monitoring). These values are not user-configurable. These items show N/A if no IDE device is installed in the system.

Type [Auto]

Selects the type of IDE drive. Setting to [Auto] allows automatic selection of the appropriate IDE device type. Select [CDROM] if you are specifically configuring a CD-ROM drive. Select [ARMD] (ATAPI Removable Media Device) if your device is either a ZIP, LS-120, or MO drive. Configuration options: [Not Installed] [Auto] [CDROM] [ARMD]

LBA/Large Mode [Auto]

Enables or disables the LBA mode. Setting to [Auto] enables the LBA mode if the device supports this mode, and if the device was not previously formatted with LBA mode disabled. Configuration options: [Disabled] [Auto]

Block (Multi-Sector Transfer) M [Auto]

Enables or disables data multi-sectors transfers. When set to [Auto], the data transfer from and to the device occurs multiple sectors at a time if the device supports multi-sector transfer feature. When set to [Disabled], the data transfer from and to the device occurs one sector at a time.

Configuration options: [Disabled] [Auto]

PIO Mode [Auto]

Selects the PIO mode. Configuration options: [Auto] [0] [1] [2] [3] [4]

DMA Mode [Auto]

Selects the DMA mode. Configuration options: [Auto]

SMART Monitoring [Auto]

Sets the Smart Monitoring, Analysis, and Reporting Technology.

Configuration options: [Auto] [Disabled] [Enabled]

32Bit Data Transfer [Enabled]

Enables or disables 32-bit data transfer. Configuration options: [Disabled] [Enabled]

2.3.5 Storage Configuration

The items in this menu allow you to set or change the configurations for the storage devices installed in the system. Select an item then press <Enter> if you want to configure the item.

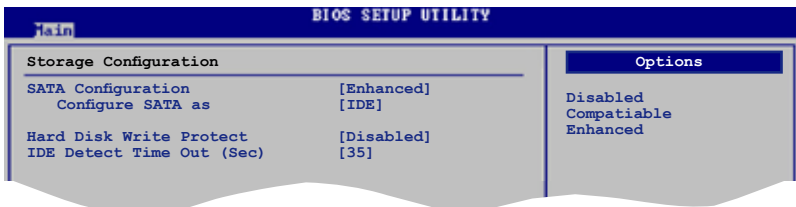

SATA Configuration [Enhanced]

Allows you to enable or disable SATA configuration.

Configuration options: [Disabled] [Compatible] [Enhanced]

Configure SATA as [IDE]

Sets the configuration for the Serial ATA connectors supported by the Southbridge chip. Configuration options: [IDE] [AHCI]

Hard Disk Write Protect [Disabled]

Disables or enables device write protection. This will be effective only if device is accessed through BIOS. Configuration option: [Disabled] [Enabled]

IDE Detect Time Out (Sec) [35]

Selects the time out value for detecting ATA/ATAPI devices.

Configuration options: [0] [5] [10] [15] [20] [25] [30] [35]

2.3.6 System Information

This menu gives you an overview of the general system specifications. The BIOS automatically detects the items in this menu.

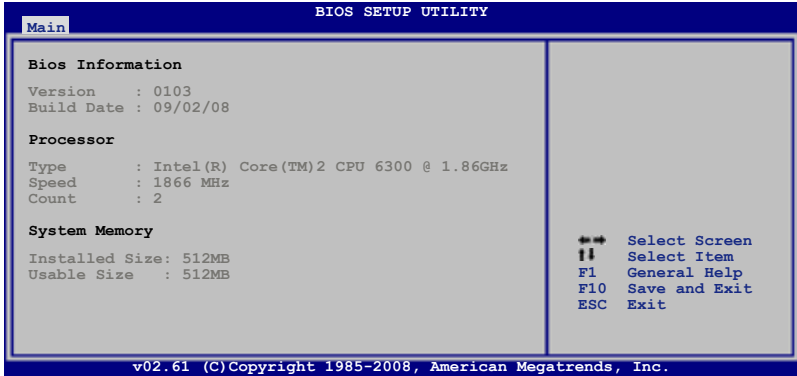

AMI BIOS

Displays the auto-detected BIOS information.

Processor

Displays the auto-detected CPU specification.

System Memory

Displays the auto-detected system memory.

2.4 Ai Tweaker menu

The Ai Tweaker menu items allow you to change the settings for system performance.

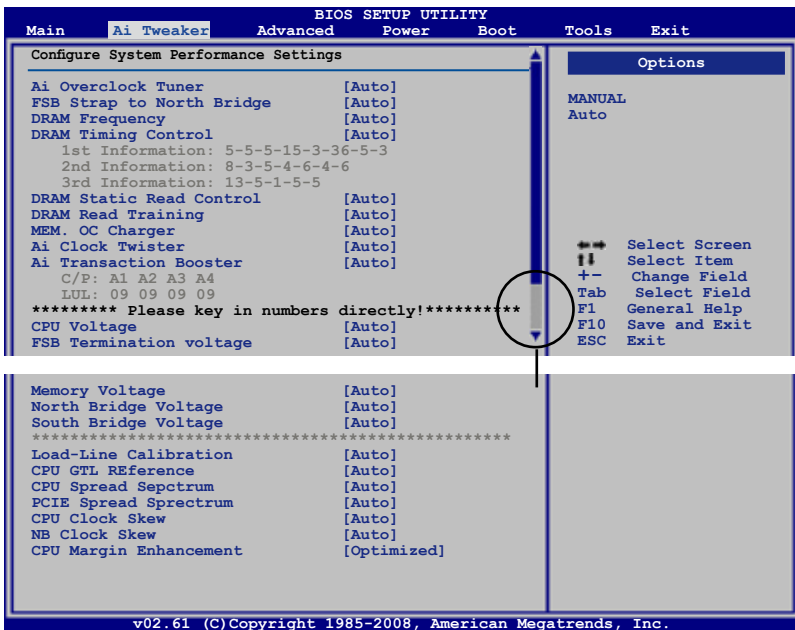

2.4.1 Ai Overclock Tuner [Auto]

Allows selection of CPU overclocking options to achieve desired CPU internal frequency. Select either one of the preset overclocking configuration options:

Manual	Allows you to individually set overclocking parameters.
Auto	Loads the optimal settings for the system.



The following two items appear only when you set the **Ai Overclock Tuner** item to [Manual].

FSB Frequency [XXX]

Displays the frequency sent by the clock generator to the system bus and PCI bus. The value of this item is auto-detected by the BIOS. Use the <+> and <-> keys to adjust the FSB frequency. You can also type the desired CPU frequency using the numeric keypad. The values range from 200 to 800. Refer to the table below for the correct Front Side Bus and CPU External Frequency settings.

FSB/CPU External Frequency Synchronization

Front Side Bus	CPU External Frequency
FSB 1600	400 MHz
FSB 1333	333 MHz
FSB 1066	266 MHz
FSB 800	200 MHz

PCIe Frequency [Auto]

Allows you to set the PCI Express frequency. Use the <+> and <-> keys to adjust the PCIe frequency. The values range from 100 to 180.

2.4.2 FSB Strap to North Bridge [Auto]

When set to [Auto], the FSB Strap will be adjusted automatically by FSB Frequency and DRAM Frequency. Configuration options: [Auto] [200MHz] [266MHz] [333MHz] [400 MHz]

2.4.3 DRAM Frequency [Auto]

Allows you to set the DDR2 operating frequency.
Configuration options: [Auto] [DDR2-533 MHz] [DDR2-639 MHz] [DDR2-667 MHz] [DDR2-709 MHz] [DDR2-800 MHz] [DDR2-852 MHz] [DDR2-887 MHz] [DDR2-1066 MHz] [DDR2-*1200 MHz*]



The **DRAM Frequency** configuration options vary with the **FSB Frequency** item settings.



Selecting a very high DRAM frequency may cause the system to become unstable! If this happens, revert to the default setting.

2.4.4 DRAM Timing Control [Auto]

Allows you to set the DRAM timing control. Configuration options: [Auto] [Manual]



- The following sub-items appear only when you set the **DRAM Timing Control** item to [Manual].
- The configuration options for some of the following items vary depending on the DIMMs you install on the motherboard.

1st Information: 5-5-5-15-3-36-5-3

The values vary depending on your settings of the following sub-items:

CAS# Latency [5 DRAM Clocks]

Configuration options: [3 DRAM Clocks] [4 DRAM Clocks] [5 DRAM Clocks] [6 DRAM Clocks] [7 DRAM Clocks] [8 DRAM Clocks] [9 DRAM Clocks] [10 DRAM Clocks] [11 DRAM Clocks]

DRAM RAS# to CAS# Delay [5 DRAM Clocks]

Configuration options: [3 DRAM Clocks] [4 DRAM Clocks] – [17 DRAM Clocks] [18 DRAM Clocks]

DRAM RAS# Precharge [5 DRAM Clocks]

Configuration options: [3 DRAM Clocks] [4 DRAM Clocks] – [17 DRAM Clocks] [18 DRAM Clocks]

RAS# Activate to Precharge [15 DRAM Clocks]

Configuration options: [3 DRAM Clocks] [4 DRAM Clocks] – [33 DRAM Clocks] [34 DRAM Clocks]

RAS# to RAS# Delay [Auto]

Configuration options: [Auto] [1 DRAM Clocks] – [15 DRAM Clocks]

Row Refresh Cycle Time [Auto]

Configuration options: [Auto] [20 DRAM Clocks] [25 DRAM Clocks] [30 DRAM Clocks] [35 DRAM Clocks] [40 DRAM Clocks] [45 DRAM Clocks] [50 DRAM Clocks] [55 DRAM Clocks] [60 DRAM Clocks] [65 DRAM Clocks] [70 DRAM Clocks] [80 DRAM Clocks] [85 DRAM Clocks] [105 DRAM Clocks] [132 DRAM Clocks]

Write Recovery Time [Auto]

Configuration options: [Auto] [1 DRAM Clocks] – [15 DRAM Clocks]

Read to Precharge Time [Auto]

Configuration options: [Auto] [1 DRAM Clocks] – [15 DRAM Clocks]

2nd Information: 8-3-5-4-6-4-6

The values vary depending on your settings of the following sub-items:

READ to WRITE Delay(S/D) [Auto]

Configuration options: [Auto] [1 DRAM Clocks] – [15 DRAM Clocks]

Write to Read Delay(S) [Auto]

Configuration options: [Auto] [1 DRAM Clocks] – [15 DRAM Clocks]

WRITE to READ Delay(D) [Auto]

Configuration options: [Auto] [1 DRAM Clocks] – [15 DRAM Clocks]

READ to READ Delay(S) [Auto]

Configuration options: [Auto] [1 DRAM Clocks] – [15 DRAM Clocks]

READ to READ Delay(D) [Auto]

Configuration options: [Auto] [1 DRAM Clocks] – [15 DRAM Clocks]

WRITE to WRITE Delay(S) [Auto]

Configuration options: [Auto] [1 DRAM Clocks] – [15 DRAM Clocks]

WRITE to WRITE Delay(D) [Auto]

Configuration options: [Auto] [1 DRAM Clocks] – [15 DRAM Clocks]

3rd Information: 13-5-1-5-5

The values vary depending on your settings of the following sub-items:

WRITE to PRE Delay [Auto]

Configuration options: [Auto] [1 DRAM Clocks] – [31 DRAM Clocks]

READ to PRE Delay [Auto]

Configuration options: [Auto] [1 DRAM Clocks] – [15 DRAM Clocks]

PRE to PRE Delay [Auto]

Configuration options: [Auto] [1 DRAM Clocks] – [3 DRAM Clocks]

ALL PRE to ACT Delay [Auto]

Configuration options: [Auto] [1 DRAM Clocks] – [15 DRAM Clocks]

ALL PRE to REF Delay [Auto]

Configuration options: [Auto] [1 DRAM Clocks] – [15 DRAM Clocks]

2.4.5 DRAM Static Read Control [Auto]

Adjusting this item might enhance DRAM overclocking ability.

Configuration options: [Auto] [Disabled] [Enabled]

2.4.6 DRAM Read Training [Auto]

Allows you to set DRAM read data timing optimization. Setting this item to [Disabled] may help enhance DRAM overclocking ability.

Configuration options: [Auto] [Disabled] [Enabled]

2.4.7 MEM. OC Charger [Auto]

Allows you to enable or disable the memory overclocking charger feature. Setting this item to [Enabled] may help enhance DRAM overclocking ability. Configuration options: [Auto] [Disabled] [Enabled]

2.4.8 Ai Clock Twister [Auto]

Allows you to set the DRAM performance. Set this item to [Light] or [Lighter] to enhance DRAM compatibility, or [Strong] or [Stronger] to accelerate DRAM performance. Configuration options: [Auto] [Lighter] [Light] [Moderate] [Strong] [Stronger]

2.4.9 Ai Transaction Booster [Auto]

Allows you to set the system performance. Configuration options: [Auto] [Manual]



The following two sub-items appear only when you set the **Ai Transaction Booster** item to [Manual].

Common Performance Level [05]

Set this item to a higher level for better compatibility or a lower level for better performance. Use the <+> and <-> keys to adjust the value. The values range from 1 to 31.

Pull-In of CHA/B PH1/2/3/4 [Disabled]

Set this item to [Enabled] to apply enhancement on DRAM Channel A and B, Phase 1 to 4. The number of phases is determined by DRAM frequency and FSB strap. Configuration options: [Disabled] [Enabled]



The following ten (10) items on the next page are adjusted by typing the desired values using the numeric keypad and press the <Enter> key. You can also use the <+> and <-> keys to adjust the value. To restore the default setting, type [auto] using the keyboard and press the <Enter> key.

2.4.10 CPU Voltage [Auto]

Allows you to set the CPU VCore voltage. The values range from 0.85000V to 1.50000V with a 0.00625V interval.



Refer to the CPU documentation before setting the CPU Vcore voltage. Setting a high VCore voltage may damage the CPU permanently, and setting a low VCore voltage may make the system unstable.

2.4.11 FSB Termination Voltage [Auto]

Allows you to set the front side bus termination voltage. The values range from 1.20V* to 1.50V with a 0.10V interval.



The minimum value of this item becomes 1.10V when a 45nm CPU is installed.

2.4.12 Memory Voltage [Auto]

Allows you to set the Memory voltage. The values range from 1.80V to 2.30V with a 0.10V interval.

2.4.13 North Bridge Voltage [Auto]

Allows you to set the North Bridge voltage. The values range from 1.10V to 1.40V* with a 0.10V interval.



-
- Setting the **CPU Voltage**, **FSB Termination Voltage**, **Memory Voltage** and **North Bridge Voltage** items to a high level may damage the chipset, memory module and CPU permanently. Proceed with caution.
 - The system may need better cooling system to work stably under high voltage settings.
-

2.4.14 South Bridge Voltage [Auto]

Allows you to set the South Bridge voltage. The values range from 1.50V to 1.70V with a 0.20V interval.

2.4.15 Load-Line Calibration [Auto]

Allows you to select the CPU Load-Line mode. Set to [Disabled] to follow Intel specifications, or to [Enabled] to improve CPU VDrop directly.

Configuration options: [Auto] [Disabled] [Enabled]

2.4.16 CPU GTL Reference [Auto]

Allows you to enable or set CPU GTL Reference. Set a very high voltage may damage the component permanently, set a very low voltage may cause the system to become unstable. Configuration options: [Auto] [0.667V] [0.65V] [0.63V] [0.615V]

2.4.17 CPU Spread Spectrum [Auto]

Set to [Disabled] to enhance FSB overclocking ability or [Auto] for EMI control.

Configuration options: [Auto] [Disabled]

2.4.18 PCIE Spread Spectrum [Auto]

Set to [Disabled] to enhance PCIE overclocking ability or [Auto] for EMI control.

Configuration options: [Auto] [Disabled]

2.4.19 CPU Clock Skew [Auto]

Configuration options: [Auto] [Normal] [Delay 100ps] [Delay 200ps] [Delay 300ps] [Delay 400ps] – [Delay 1400ps] [Delay 1500ps]

2.4.20 NB Clock Skew [Auto]

Configuration options: [Auto] [Normal] [Delay 100ps] [Delay 200ps] [Delay 300ps] [Delay 400ps] – [Delay 1400ps] [Delay 1500ps]

2.4.21 CPU Margin Enhancement [Optimized]

Allows you to set the CPU Margin Enhancement.

Configuration options: [Optimized] [Compatible] [Performance Mode]

2.5 Advanced menu

The Advanced menu items allow you to change the settings for the CPU and other system devices.



Take caution when changing the settings of the Advanced menu items. Incorrect field values can cause the system to malfunction.

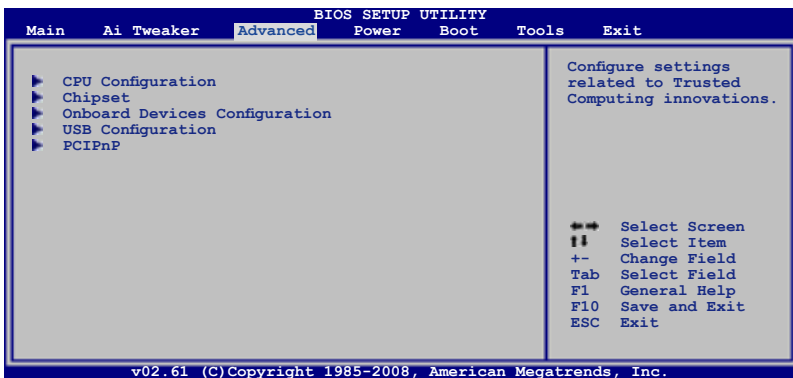

2.5.1 CPU Configuration

The items in this menu show the CPU-related information that the BIOS automatically detects.

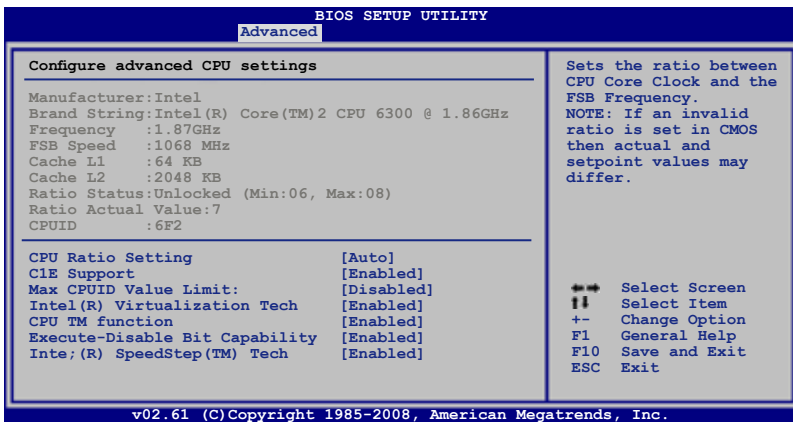

CPU Ratio Setting [Auto]

Allows you to adjust the ratio between CPU Core Clock and FSB Frequency. Use the <+> and <-> keys to adjust the value.

Configuration options: [Auto] [06.0] [07.0] [08.0]

C1E Support [Enabled]

Allows you to enable or disable Inter CPU Enhanced Halt (C1E) function, a CPU power-saving function in system halt state. When enable, the CPU core frequency and voltage will be reduced during the system halt state to decrease power consumption. Configuration options: [Disabled] [Enabled]

Max CPUID Value Limit [Disabled]

Allows you to determine whether to limit CPUID maximum value. Set this item to [Disabled] for Windows XP operating system; set this item to [Enabled] for legacy operating system such as Windows NT4.0. (Default: Disabled)
Configuration options: [Disabled] [Enabled]

Intel(R) Virtualization Tech [Enabled]

Allows you to enable or disable Intel® Virtualization Technology. Virtualization enhanced by Intel® Virtualization Technology allows a platform to run multiple operating systems and applications in independent partitions. With virtualization, one computer system can function as multiple virtual systems.
Configuration options: [Enabled] [Disabled]

CPU TM Function [Enabled]

Enables or disables Intel® CPU Thermal Monitor (TM) function, a CPU overheating protection function. When enabled, the CPU core frequency and voltage are reduced when the CPU overheats. Configuration options: [Disabled] [Enabled]

Execute-Disable Bit Capability [Enabled]

Allows you to enable or disable Intel® Execute Disable Bit Capability. This function enhance protection of your computer, reducing exposure to viruses and malicious buffer overflow attacks when working with its supporting software and system.
Configuration options: [Disabled] [Enabled]



The following item appears only when you installed an Intel® Pentium® 4 or later CPU that supports the Enhanced Intel SpeedStep® Technology (EIST).

Intel(R) SpeedStep(TM) Tech [Enabled]

Allows you to use the Enhanced Intel® SpeedStep™ Technology. When set to [Enabled], you can adjust the system power settings in the operating system to use the EIST feature. Set this item to [Disabled] if you do not want to use the EIST.
Configuration options: [Enabled] [Disabled]

2.5.2 Chipset

The Chipset menu allows you to change the advanced chipset settings. Select an item then press <Enter> to display the sub-menu.

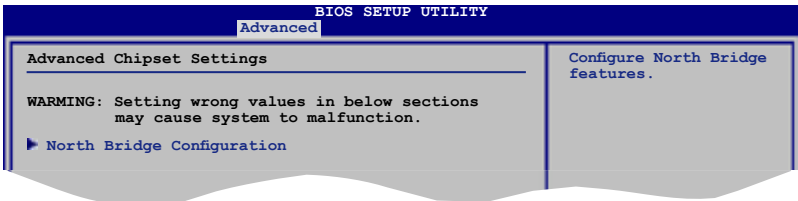

North Bridge Configuration

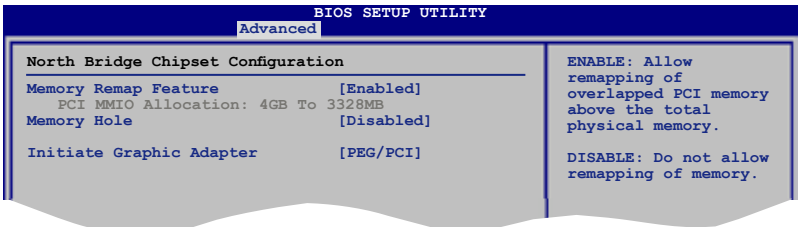

Memory Remap Feature [Enabled]

Allows you to enable or disable the remapping of the overlapped PCI memory above the total physical memory. Enable this option only when you install 64-bit operating system. Configuration options: [Disabled] [Enabled]

Memory Hole [Disabled]

Allows you to enable or disable the Memory Hole.
Configuration options: [Disabled] [15MB-16MB]

Initiate Graphic Adapter [PEG/PCI]

Allows you to decide which graphics controller to use as the primary boot device. Configuration options: [PCI/PEG] [PEG/PCI]

2.5.3 OnBoard Devices Configuration

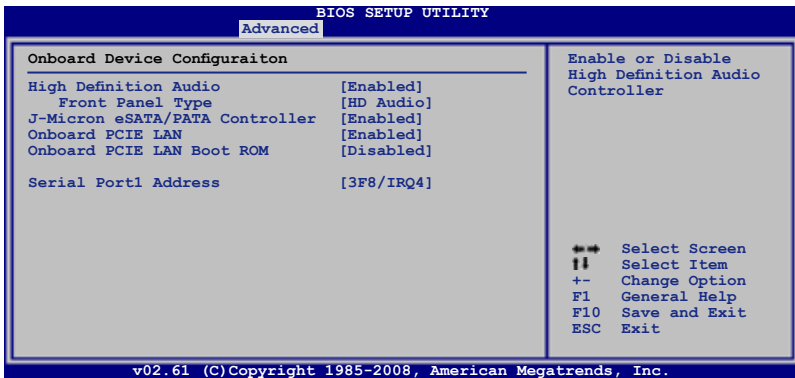

High Definition Audio [Enabled]

Allows you to enable or disable the High Definition Audio. The following item appears only when you enable this item. Configuration options: [Enabled] [Disabled]

Front Panel Type [HD Audio]

Allows you to set the front panel audio connector (AAFP) mode to legacy AC'97 or high-definition audio depending on the audio standard that the front panel audio module supports. Configuration options: [AC97] [HD Audio]

J-Micron eSATA/PATA Controller [Enabled]

Allows you to disable or enable the onboard JMicron® eSATA/PATA controller. Configuration options: [Enabled] [Disabled]

Onboard PCIE LAN [Enabled]

Allows you to enable or disable the onboard PCIE LAN. Configuration options: [Enabled] [Disabled]

Onboard PCIE LAN Boot ROM [Disabled]

This item appears only when you enable the previous item. Configuration options: [Disabled] [Enabled]

Serial Port1 Address [3F8/IRQ4]

Allows you to select the Serial Port1 base address. Configuration options: [Disabled] [3F8/IRQ4] [2F8/IRQ3] [3E8/IRQ4] [2E8/IRQ3]

2.5.4 USB Configuration

The items in this menu allows you to change the USB-related features. Select an item then press <Enter> to display the configuration options.

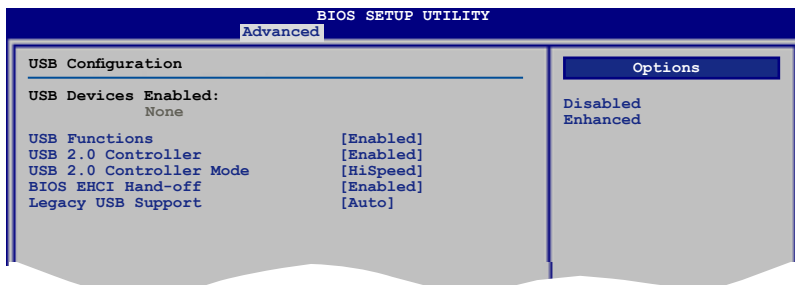

The **USB Devices Enabled** item shows auto-detected values. If no USB device is detected, the item shows **None**.

USB Functions [Enabled]

Allows you to enable or disable the USB functions. The following sub-items appear when this item is set to [Enabled]. Configuration options: [Disabled] [Enabled]

USB 2.0 Controller [Enabled]

Allows you to enable or disable the USB 2.0 controller. Configuration options: [Enabled] [Disabled]

USB 2.0 Controller Mode [HiSpeed]

Allows you to set the USB 2.0 controller mode to HiSpeed (480 Mbps) or FullSpeed (12 Mbps). This item appears only when you enable the USB 2.0 Controller item. Configuration options: [FullSpeed] [HiSpeed]

BIOS EHCI Hand-off [Enabled]

Allows you to enable support for operating systems without an EHCI hand-off feature. Configuration options: [Disabled] [Enabled]

Legacy USB Support [Auto]

Allows you to enable or disable support for legacy USB devices. Setting to [Auto] allows the system to detect the presence of USB devices at startup. If detected, the USB controller legacy mode is enabled. If no USB device is detected, the legacy USB support is disabled. Configuration options: [Disabled] [Enabled] [Auto]

2.5.5 PCI PnP

The PCI PnP menu items allow you to change the advanced settings for PCI/PnP devices.



Take caution when changing the settings of the PCI PnP menu items. Incorrect field values can cause the system to malfunction.

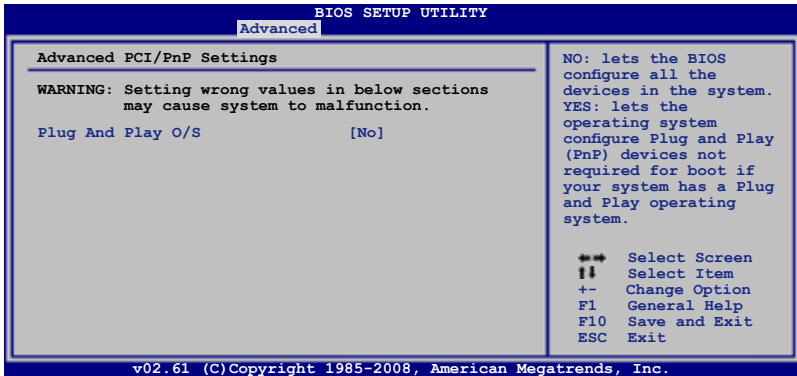

Plug And Play O/S [No]

When set to [No], BIOS configures all the devices in the system. When set to [Yes] and if you install a Plug and Play operating system, the operating system configures the Plug and Play devices not required for boot.

Configuration options: [No] [Yes]

2.6 Power menu

The Power menu items allow you to change the settings for the Advanced Power Management (APM). Select an item then press <Enter> to display the configuration options.

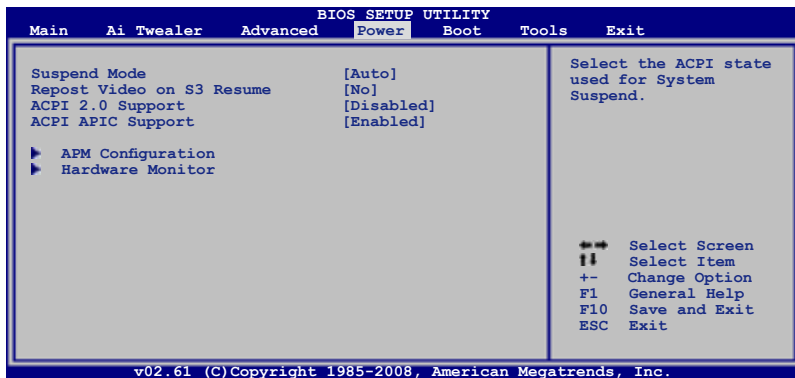

2.6.1 Suspend Mode [Auto]

Allows you to select the Advanced Configuration and Power Interface (ACPI) state to be used for system suspend. Configuration options: [S1 (POS) only] [S3 only] [Auto]

2.6.2 Repost Video on S3 Resume [No]

Determines whether to invoke VGA BIOS POST on S3/STR resume. Configuration options: [No] [Yes]

2.6.3 ACPI 2.0 Support [Disabled]

Allows you to select the Advanced Configuration and Power Interface (ACPI) 2.0 support. Configuration options: [Disabled] [Enabled]

2.6.4 ACPI APIC Support [Enabled]

Allows you to enable or disable the Advanced Configuration and Power Interface (ACPI) support in the Advanced Programmable Interrupt Controller (APIC). When set to Enabled, the ACPI APIC table pointer is included in the RSDT pointer list. Configuration options: [Disabled] [Enabled]

2.6.5 APM Configuration

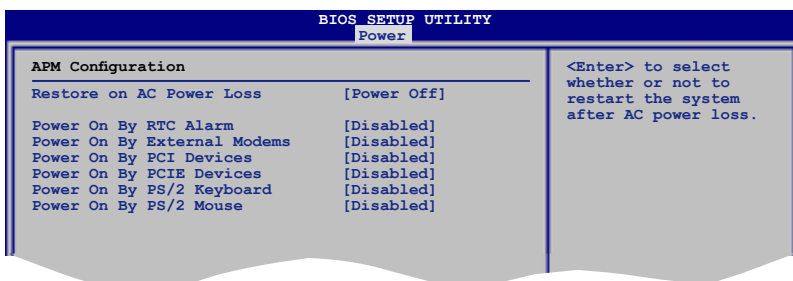

Restore On AC Power Loss [Power Off]

When set to Power Off, the system goes into off state after an AC power loss. When set to Power On, the system goes on after an AC power loss. When set to Last State, the system goes into either off or on state, whatever the system state was before the AC power loss. Configuration options: [Power Off] [Power On] [Last State]

Power On By RTC Alarm [Disabled]

Allows you to enable or disable RTC to generate a wake event. When this item is set to Enabled, the items RTC Alarm Date/ RTC Alarm Hour/ RTC Alarm Minute/ RTC Alarm Second will become user-configurable with set values. Configuration options: [Disabled] [Enabled]

Power On By External Modems [Disabled]

This allows either settings of [Enabled] or [Disabled] for powering up the computer when the external modem receives a call while the computer is in Soft-off mode. Configuration options: [Disabled] [Enabled]



The computer cannot receive or transmit data until the computer and applications are fully running. Thus, connection cannot be made on the first try. Turning an external modem off and then back on while the computer is off causes an initialization string that turns the system power on.

Power On By PCI Devices [Disabled]

Allows you to enable or disable the PME to wake up from S5 by PCI devices. Configuration options: [Disabled] [Enabled]

Power On By PCIE Devices [Disabled]

Allows you to enable or disable the PCIE devices to generate a wake event. Configuration options: [Disabled] [Enabled]

Power On By PS/2 Keyboard [Disabled]

Allows you to disable the Power On by PS/2 keyboard function or set specific keys on the PS/2 keyboard to turn on the system. This feature requires an ATX power supply that provides at least 1A on the +5VSB lead.

Configuration options: [Disabled] [Space Bar] [Ctrl-Esc] [Power Key]

Power On By PS/2 Mouse [Disabled]

Allows you to enable or disable the Power On by PS/2 mouse function.

Configuration options: [Disabled] [Enabled]

2.6.6 Hardware Monitor

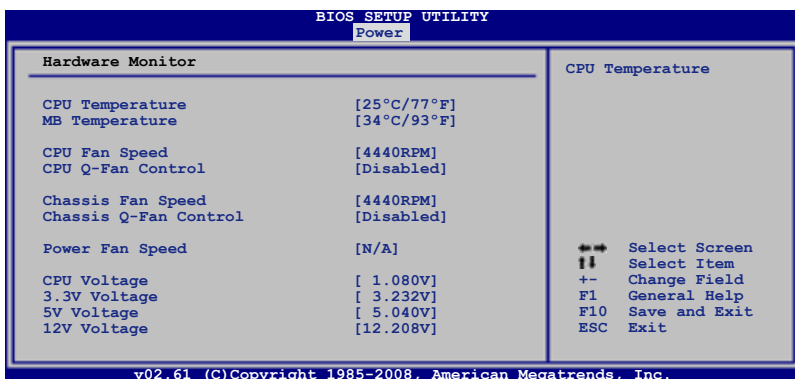

CPU Temperature [xxx°C/xxx°F]

MB Temperature [xxx°C/xxx°F]

The onboard hardware monitor automatically detects and displays the motherboard and CPU temperatures. Select [Ignored] if you do not wish to display the detected temperatures.

CPU Fan Speed [xxxxRPM] or [Ignored] / [N/A]

The onboard hardware monitor automatically detects and displays the CPU fan speed in rotations per minute (RPM). If the fan is not connected to the motherboard, the field shows N/A.

CPU Q-Fan Control [Disabled]

Allows you to enable or disable the CPU Q-Fan controller.

Configuration options: [Disabled] [Enabled]



The **CPU Fan Profile** item appears when you enable the CPU Q-Fan Control feature.

CPU Fan Profile [Standard]

Allows you to set the appropriate performance level of the CPU Q-Fan. When set to [Standard], the CPU fan automatically adjusts depending on the CPU temperature. Set this item to [Silent] to minimize fan speed for quiet CPU fan operation, or [Turbo] to enable slight quiet operation for heavy-loading computing. Configuration options: [Standard] [Silent] [Turbo]

Chassis Fan Speed [xxxxRPM] or [Ignored] / [N/A]

The onboard hardware monitor automatically detects and displays the chassis fan speed in rotations per minute (RPM). If the fan is not connected to the motherboard, the field shows N/A.

Chassis Q-Fan Control [Disabled]

Allows you to enable or disable the chassis Q-Fan controller. Configuration options: [Disabled] [Enabled]



The **Chassis Fan Profile** item appears when you enable the Chassis Q-Fan Control feature.

Chassis Fan Ratio [Standard]

Allows you to set the appropriate performance level of the Chassis Q-Fan. When set to [Standard], the chassis fan automatically adjusts depending on the chassis temperature. Set this item to [Silent] to minimize fan speed for quiet chassis fan operation, or [Turbo] to enable slight quiet operation for heavy-loading computing. Configuration options: [Standard] [Silent] [Turbo]

Power Fan Speed (RPM) [xxxxRPM] or [Ignored] / [N/A]

The onboard hardware monitor automatically detects and displays the power fan speed in rotations per minute (RPM). If the fan is not connected to the motherboard, the field shows N/A.

CPU Voltage, 3.3V Voltage, 5V Voltage, 12V Voltage

The onboard hardware monitor automatically detects the voltage output through the onboard voltage regulators. Select [Ignored] if you do not want to detect this item.

2.7 Boot menu

The Boot menu items allow you to change the system boot options. Select an item then press <Enter> to display the sub-menu.

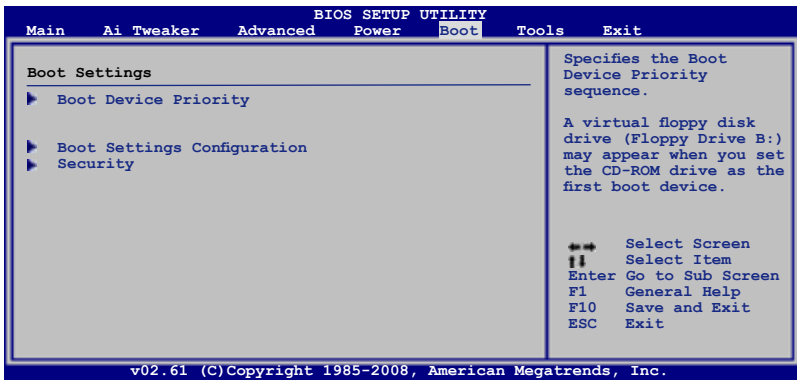

2.7.1 Boot Device Priority

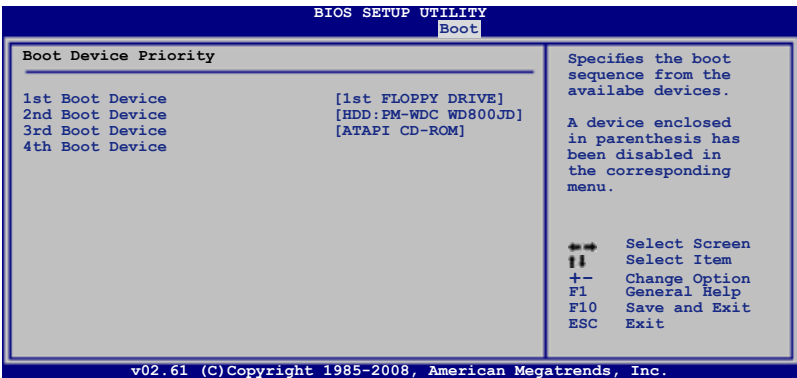

1st ~ xxth Boot Device [xxx Drive]

These items specify the boot device priority sequence from the available devices. The number of device items that appears on the screen depends on the number of devices installed in the system. Configuration options: [1st FLOPPY DRIVE] [Hard Drive] [ATAPI CD-ROM] [Disabled]

2.7.2 Boot Settings Configuration

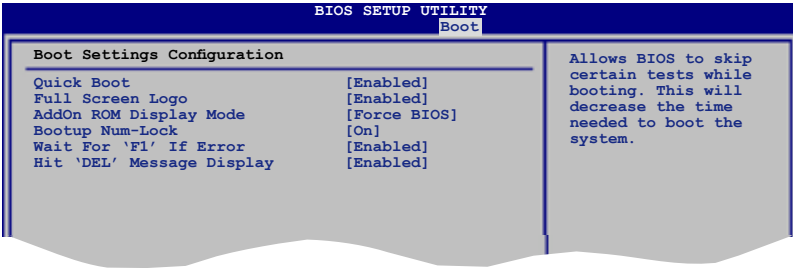

Quick Boot [Enabled]

Enabling this item allows the BIOS to skip some power on self tests (POST) while booting to decrease the time needed to boot the system. When set to [Disabled], BIOS performs all the POST items. Configuration options: [Disabled] [Enabled]

Full Screen Logo [Enabled]

Allows you to enable or disable the full screen logo display feature. Configuration options: [Disabled] [Enabled]



Set this item to [Enabled] to use the ASUS MyLogo 2™ feature.

Add On ROM Display Mode [Force BIOS]

Sets the display mode for option ROM. Configuration options: [Force BIOS] [Keep Current]

Bootup Num-Lock [On]

Allows you to select the power-on state for the NumLock. Configuration options: [Off] [On]

Wait for 'F1' If Error [Enabled]

When set to Enabled, the system waits for the F1 key to be pressed when error occurs. Configuration options: [Disabled] [Enabled]

Hit 'DEL' Message Display [Enabled]

When set to Enabled, the system displays the message "Press DEL to run Setup" during POST. Configuration options: [Disabled] [Enabled]

2.7.3 Security

The Security menu items allow you to change the system security settings. Select an item then press <Enter> to display the configuration options.

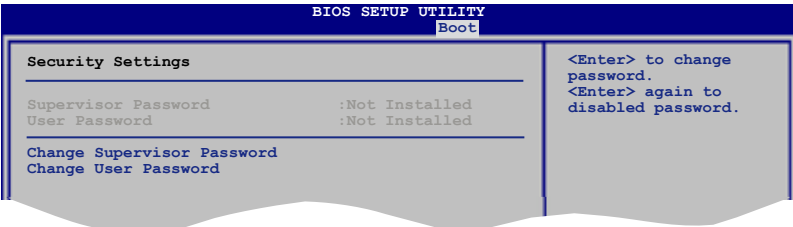

Change Supervisor Password

Select this item to set or change the supervisor password. The Supervisor Password item on top of the screen shows the default Not Installed. After you set a password, this item shows Installed.

To set a Supervisor Password:

1. Select the Change Supervisor Password item and press <Enter>.
2. From the password box, type a password composed of at least six letters and/or numbers, then press <Enter>.
3. Confirm the password when prompted.

The message "Password Installed" appears after you successfully set your password.

To change the supervisor password, follow the same steps as in setting a user password.

To clear the supervisor password, select the Change Supervisor Password then press <Enter>. The message "Password Uninstalled" appears.



If you forget your BIOS password, you can clear it by erasing the CMOS Real Time Clock (RTC) RAM. See section "2.6 Jumpers" for information on how to erase the RTC RAM.

After you have set a supervisor password, the other items appear to allow you to change other security settings.

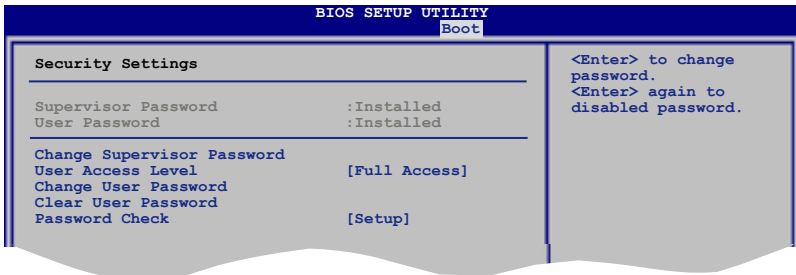

User Access Level [Full Access]

This item allows you to select the access restriction to the Setup items.

Configuration options: [No Access] [View Only] [Limited] [Full Access]

No Access prevents user access to the Setup utility.

View Only allows access but does not allow change to any field.

Limited allows changes only to selected fields, such as Date and Time.

Full Access allows viewing and changing all the fields in the Setup utility.

Change User Password

Select this item to set or change the user password. The User Password item on top of the screen shows the default Not Installed. After you set a password, this item shows Installed.

To set a User Password:

1. Select the Change User Password item and press <Enter>.
2. On the password box that appears, type a password composed of at least six letters and/or numbers, then press <Enter>.
3. Confirm the password when prompted.

The message "Password Installed" appears after you set your password successfully.

To change the user password, follow the same steps as in setting a user password.

Clear User Password

Select this item to clear the user password.

Password Check [Setup]

When set to [Setup], BIOS checks for user password when accessing the Setup utility. When set to [Always], BIOS checks for user password both when accessing Setup and booting the system. Configuration options: [Setup] [Always]

2.8 Tools menu

The Tools menu items allow you to configure options for special functions. Select an item then press <Enter> to display the sub-menu.



2.8.1 ASUS EZ Flash 2

Allows you to run ASUS EZ Flash 2. When you press <Enter>, a confirmation message appears. Use the left/right arrow key to select between [Yes] or [No], then press <Enter> to confirm your choice. See section 2.1.3 for details.

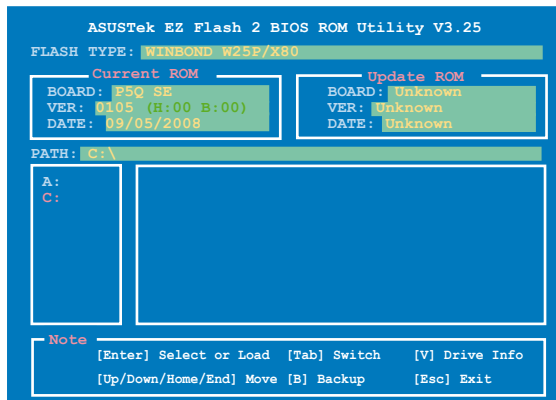

2.8.2 Express Gate [Enabled]

Allows you to enable or disable Express Gate. Configuration options: [Disabled] [Enabled]

Enter OS Timer [10 Seconds]

Allows you to set the countdown duration that the system waits at the Express Gate's first screen before starting Windows or other installed OS.

Configuration options: [Prompt User] [1 Second] [3 Seconds] [5 Seconds] [10 Seconds] [15 Seconds] [20 Seconds] [30 Seconds]

Reset User Data [No]

Allows you reset user data. When set to [Reset], user data will be cleared, and reboot to Express Gate. Configuration options: [No] [Reset]

2.8.3 AI NET 2

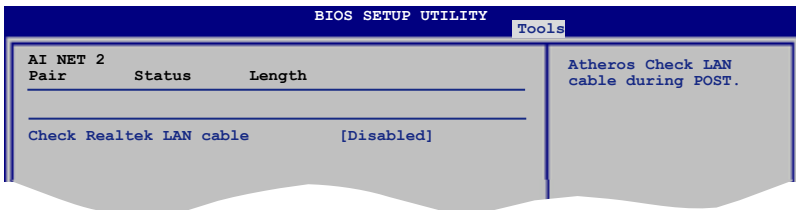

Check Realtek LAN cable [Disabled]

Enables or disables checking of the Realtek LAN cable during the Power-On Self-Test (POST). Configuration options: [Disabled] [Enabled]

2.8.4 ASUS O.C. Profile

This item allows you to store or load multiple BIOS settings.

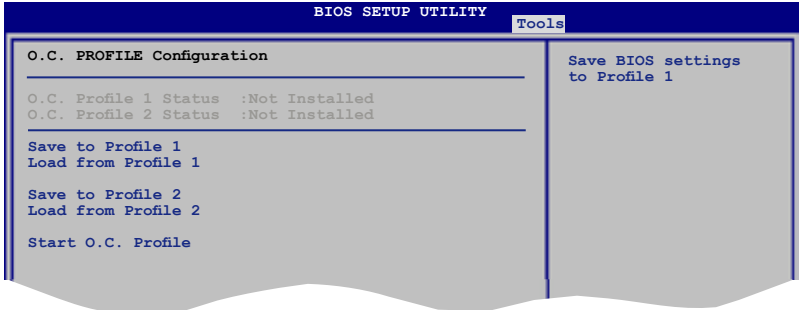

Save to Profile 1/2

Allows you to save the current BIOS file to the BIOS Flash. Press <Enter> to save the file.

Load from Profile 1/2

Allows you to load the previous BIOS settings saved in the BIOS Flash. Press <Enter> to load the file.

Start O.C. Profile

Allows you to run the utility to save and load CMOS. Press <Enter> to run the utility.

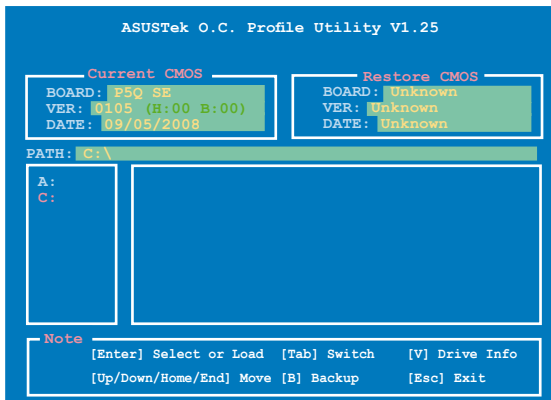

- This function can support devices such as USB flash disk or floppy disk with FAT 32/16 format and single partition only.
- DO NOT shut down or reset the system while updating the BIOS to prevent the system boot failure!

2.9 Exit menu

The Exit menu items allow you to load the optimal or failsafe default values for the BIOS items, and save or discard your changes to the BIOS items.

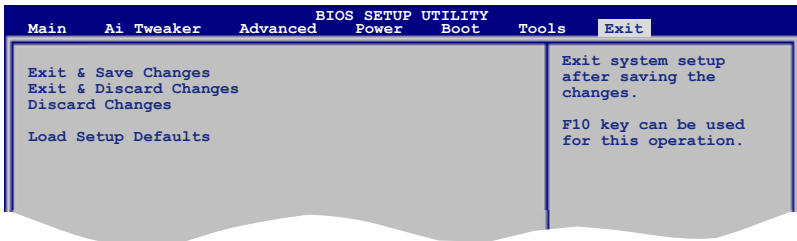

Pressing <Esc> does not immediately exit this menu. Select one of the options from this menu or <F10> from the legend bar to exit.

Exit & Save Changes

Once you are finished making your selections, choose this option from the Exit menu to ensure the values you selected are saved to the CMOS RAM. An onboard backup battery sustains the CMOS RAM so it stays on even when the PC is turned off. When you select this option, a confirmation window appears. Select **OK** to save changes and exit.



If you attempt to exit the Setup program without saving your changes, the program prompts you with a message asking if you want to save your changes before exiting. Press <Enter> to save the changes while exiting.

Exit & Discard Changes

Select this option only if you do not want to save the changes that you made to the Setup program. If you made changes to fields other than System Date, System Time, and Password, the BIOS asks for a confirmation before exiting.

Discard Changes

This option allows you to discard the selections you made and restore the previously saved values. After selecting this option, a confirmation appears. Select **OK** to discard any changes and load the previously saved values.

Load Setup Defaults

This option allows you to load the default values for each of the parameters on the Setup menus. When you select this option or if you press <F5>, a confirmation window appears. Select **OK** to load default values. Select **Exit & Save Changes** or make other changes before saving the values to the non-volatile RAM.

This chapter describes the contents of the support DVD that comes with the motherboard package.

3 Software support

3.1 Installing an operating system

This motherboard supports Windows® XP/64-bit XP/Vista/64-bit Vista operating systems (OS). Always install the latest OS version and corresponding updates to maximize the features of your hardware.



- Motherboard settings and hardware options vary. Use the setup procedures presented in this chapter for reference only. Refer to your OS documentation for detailed information.
- Ensure that you install the Windows® XP Service Pack2 or later versions before installing the drivers for better compatibility and system stability.

3.2 Support DVD information

The support DVD that came with the motherboard package contains the drivers, software applications, and utilities that you can install to avail all motherboard features.



The contents of the support DVD are subject to change at any time without notice. Visit the ASUS website(www.asus.com) for updates.

3.2.1 Running the support DVD

Place the support DVD to the optical drive. The DVD automatically displays the Drivers menu if Autorun is enabled in your computer.



Click an icon to display support DVD/motherboard information

Click an item to install



If Autorun is NOT enabled in your computer, browse the contents of the support DVD to locate the file ASSETUP.EXE from the BIN folder. Double-click the ASSETUP.EXE to run the DVD.

3.2.2 Drivers menu

The drivers menu shows the available device drivers if the system detects installed devices. Install the necessary drivers to activate the devices.



ASUS InstAll - Installation Wizard for Anti-Virus and Drivers Utility

Launches the ASUS installation wizard for anti-virus and drivers utility.

Norton Internet Security 2008

Installs the Norton Internet Security 2008.

Intel Chipset Driver Inf Update Program

Installs the Intel chipset driver inf update program.

Realtek RTL8111B/C LAN Drivers

Installs the Realtek LAN drivers.

VIA Audio Driver

Installs the VIA audio driver.

ASUS EPU - 4 Engine

Installs the ASUS EPU - 4 Engine driver and utility.

ASUS Express Gate Installer

Installs the ASUS Express Gate utility.

3.2.3 Utilities menu

The Utilities menu shows the applications and other software that the motherboard supports.



Click to display the next page



Click to return to the previous page

ASUS InstAll-Installation Wizard for Utilities

Installs all of the utilities through the Installation Wizard.

ASUS Update

The ASUS Update utility allows you to update the motherboard BIOS in Windows® environment. This utility requires an Internet connection either through a network or an Internet Service Provider (ISP).

ASUS PC Probe II

This smart utility monitors the fan speed, CPU temperature, and system voltages, and alerts you of any detected problems. This utility helps you keep your computer in healthy operating condition.

ASUS AI Suite

An innovative application to do overclocking, fan control, power saving and quiet thermal control.

Adobe Acrobat Reader 8

Installs Adobe Acrobat Reader that allows you to open, view and print documents in Portable Document Format (PDF).

Microsoft DirectX 9.0c

Installs the Microsoft® DirectX 9.0c driver. The Microsoft DirectX® 9.0c is a multimedia technology that enhances computer graphics and sound. DirectX® improves the multimedia features of your computer so you can enjoy watching TV and movies, capturing videos, or playing games in your computer. Visit the Microsoft website (www.microsoft.com) for updates.

Corel MediaOne Starter

Installs the Corel MediaOne Starter application to easily manage, edit share and protect your multimedia data.

CyberLink PowerBackup

Installs the CyberLink PowerBackup to back up and restore your data easily.

WinZip 11

Installs the Winzip utility for easy file-compression.

Ulead Burn Now

Installs the Ulead Burn. Now application for audio DVD, CD and data disc creation.

Ulead PhotoImpact 12 SE

Installs the PhotoImpact image editing software.

3.2.4 Manual menu

The Manual menu contains a list of supplementary user manuals. Click an item to open the folder of the user manual.



Most user manual files are in Portable Document Format (PDF). Install the Adobe® Acrobat® Reader from the Support DVD before opening a user manual file.



3.2.5 ASUS Contact information

Click the Contact tab to display the ASUS contact information. You can also find this information on the inside front cover of this user guide.

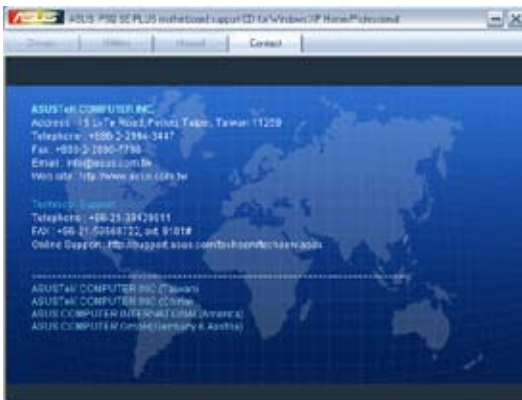

Technical support Form

Displays the ASUS Technical Support Request Form that you have to fill out when requesting technical support.

