

**P7F7-E WS**  
**Supercomputer**

**ASUS**<sup>®</sup>

**Motherboard**

E5403

First Edition  
February 2010

**Copyright © 2010 ASUSTeK COMPUTER INC. All Rights Reserved.**

No part of this manual, including the products and software described in it, may be reproduced, transmitted, transcribed, stored in a retrieval system, or translated into any language in any form or by any means, except documentation kept by the purchaser for backup purposes, without the express written permission of ASUSTeK COMPUTER INC. ("ASUS").

Product warranty or service will not be extended if: (1) the product is repaired, modified or altered, unless such repair, modification or alteration is authorized in writing by ASUS; or (2) the serial number of the product is defaced or missing.

ASUS PROVIDES THIS MANUAL "AS IS" WITHOUT WARRANTY OF ANY KIND, EITHER EXPRESS OR IMPLIED, INCLUDING BUT NOT LIMITED TO THE IMPLIED WARRANTIES OR CONDITIONS OF MERCHANTABILITY OR FITNESS FOR A PARTICULAR PURPOSE. IN NO EVENT SHALL ASUS, ITS DIRECTORS, OFFICERS, EMPLOYEES OR AGENTS BE LIABLE FOR ANY INDIRECT, SPECIAL, INCIDENTAL, OR CONSEQUENTIAL DAMAGES (INCLUDING DAMAGES FOR LOSS OF PROFITS, LOSS OF BUSINESS, LOSS OF USE OR DATA, INTERRUPTION OF BUSINESS AND THE LIKE), EVEN IF ASUS HAS BEEN ADVISED OF THE POSSIBILITY OF SUCH DAMAGES ARISING FROM ANY DEFECT OR ERROR IN THIS MANUAL OR PRODUCT.

SPECIFICATIONS AND INFORMATION CONTAINED IN THIS MANUAL ARE FURNISHED FOR INFORMATIONAL USE ONLY, AND ARE SUBJECT TO CHANGE AT ANY TIME WITHOUT NOTICE, AND SHOULD NOT BE CONSTRUED AS A COMMITMENT BY ASUS. ASUS ASSUMES NO RESPONSIBILITY OR LIABILITY FOR ANY ERRORS OR INACCURACIES THAT MAY APPEAR IN THIS MANUAL, INCLUDING THE PRODUCTS AND SOFTWARE DESCRIBED IN IT.

Products and corporate names appearing in this manual may or may not be registered trademarks or copyrights of their respective companies, and are used only for identification or explanation and to the owners' benefit, without intent to infringe.

# Contents

Notices.....	viii
Safety information .....	ix
About this guide .....	x
P7F7-E WS Supercomputerspecifications summary .....	xii

## Chapter 1: Product introduction

1.1	Welcome! .....	1-1
1.2	Package contents.....	1-1
1.3	Special features.....	1-2
1.3.1	Product highlights .....	1-2
1.3.2	ASUS Xtreme Design—Hybrid Processor .....	1-3
1.3.3	ASUS Hybrid Phase.....	1-3
1.3.4	ASUS Hybrid OS.....	1-4
1.3.5	ASUS Exclusive Features.....	1-4

## Chapter 2: Hardware information

2.1	Before you proceed .....	2-1
2.2	Motherboard overview.....	2-2
2.2.1	Motherboard layout.....	2-2
2.2.2	Layout contents.....	2-3
2.2.3	Placement direction .....	2-4
2.2.4	Screw holes .....	2-4
2.3	Central Processing Unit (CPU) .....	2-5
2.3.1	Installing the CPU .....	2-6
2.3.2	Installing the CPU heatsink and fan.....	2-9
2.3.3	Uninstalling the CPU heatsink and fan .....	2-10
2.4	System memory .....	2-11
2.4.1	Overview .....	2-11
2.4.2	Memory configurations.....	2-13
2.4.3	Installing a DIMM .....	2-27
2.4.4	Removing a DIMM .....	2-27
2.5	Expansion slots.....	2-28
2.5.1	Installing an expansion card .....	2-28
2.5.2	Configuring an expansion card .....	2-28
2.5.3	Interrupt assignments .....	2-29
2.5.4	PCI Express x1 slot.....	2-30
2.5.5	PCI Express 2.0 x16 slots.....	2-30

# Contents

- 2.6 Jumper ..... 2-31**
- 2.7 Connectors ..... 2-32**
  - 2.7.1 Rear panel connectors ..... 2-32
  - 2.7.2 Audio I/O connections ..... 2-33
  - 2.7.3 Internal connectors ..... 2-37
  - 2.7.4 Onboard switches ..... 2-46
- 2.8 Onboard LEDs ..... 2-48**
- 2.9 Starting up for the first time ..... 2-49**
- 2.10 Turning off the computer ..... 2-50**
  - 2.10.1 Using the OS shut down function ..... 2-50
  - 2.10.2 Using the dual function power switch ..... 2-50
  
- Chapter 3: BIOS setup**
- 3.1 Managing and updating your BIOS ..... 3-1**
  - 3.1.1 ASUS Update utility ..... 3-1
  - 3.1.2 ASUS EZ Flash 2 utility ..... 3-4
  - 3.1.3 BUPDATER utility ..... 3-5
  - 3.1.4 ASUS CrashFree BIOS 3 utility ..... 3-6
- 3.2 BIOS setup program ..... 3-7**
  - 3.2.1 BIOS menu screen ..... 3-8
  - 3.2.2 Menu bar ..... 3-8
  - 3.2.3 Navigation keys ..... 3-8
  - 3.2.4 Menu items ..... 3-9
  - 3.2.5 Submenu items ..... 3-9
  - 3.2.6 Configuration fields ..... 3-9
  - 3.2.7 Pop-up window ..... 3-9
  - 3.2.8 Scroll bar ..... 3-9
  - 3.2.9 General help ..... 3-9
- 3.3 Main menu ..... 3-10**
  - 3.3.1 System Time [xx:xx:xx] ..... 3-10
  - 3.3.2 System Date [Day xx/xx/xxxx] ..... 3-10
  - 3.3.3 Language [English] ..... 3-10
  - 3.3.4 SATA 1-6 ..... 3-11
  - 3.3.5 Storage Configuration ..... 3-13
  - 3.3.6 AHCI Configuration ..... 3-14
  - 3.3.7 System Information ..... 3-14



# Contents

<b>3.4</b>	<b>Ai Tweaker menu</b> .....	<b>3-15</b>
3.4.1	CPU Level Up [Auto].....	3-16
3.4.2	Ai Overclock Tuner [Auto].....	3-16
3.4.3	CPU Ratio Setting [Auto].....	3-16
3.4.4	Intel(R) SpeedStep (TM) Tech. [Enabled].....	3-17
3.4.5	Intel(R) TurboMode Tech [Enabled].....	3-17
3.4.6	Xtreme Phase Full Power Mode [Auto].....	3-17
3.4.7	DRAM Frequency [Auto].....	3-17
3.4.8	QPI Frequency [Auto].....	3-17
3.4.9	ASUS/3rd Party UI Priority [ASUS Utility].....	3-17
3.4.10	OC Tuner [Turbo Profile].....	3-18
3.4.11	Start auto tuning.....	3-18
3.4.12	DRAM Timing Control [Auto].....	3-18
3.4.13	CPU Differential Amplitude [Auto].....	3-19
3.4.14	CPU Clock Skew [Auto].....	3-19
3.4.15	CPU Voltage Mode [Offset].....	3-20
3.4.16	IMC Voltage [Auto].....	3-20
3.4.17	DRAM Voltage [Auto].....	3-20
3.4.18	CPU PLL Voltage [Auto].....	3-20
3.4.19	PCH Voltage [Auto].....	3-21
3.4.20	Load-Line Calibration [Auto].....	3-21
3.4.21	CPU Spread Spectrum [Auto].....	3-21
3.4.22	PCIE Spread Spectrum [Auto].....	3-21
<b>3.5</b>	<b>Advanced menu</b> .....	<b>3-22</b>
3.5.1	CPU Configuration.....	3-22
3.5.2	Uncore Configuration.....	3-25
3.5.3	Onboard Devices Configuration.....	3-26
3.5.4	USB Configuration.....	3-27
3.5.5	PCIPnP.....	3-28
3.5.6	Intel VT-d [Disabled].....	3-28
3.5.7	T.Probe [Disabled].....	3-28
<b>3.6</b>	<b>Power menu</b> .....	<b>3-29</b>
3.6.1	Suspend Mode [Auto].....	3-29
3.6.2	Repost Video on S3 Resume [No].....	3-29
3.6.3	ACPI 2.0 Support [Disabled].....	3-29

# Contents

3.6.6	APM Configuration .....	3-30
3.6.4	ACPI APIC Support [Enabled].....	3-30
3.6.5	EuP Ready [Disabled].....	3-30
3.6.7	Hardware Monitor .....	3-32
<b>3.7</b>	<b>Boot menu .....</b>	<b>3-34</b>
3.7.1	Boot Device Priority .....	3-34
3.7.2	Hard Disk Drives; CDROM Drives .....	3-34
3.7.3	Boot Settings Configuration .....	3-35
3.7.4	Security .....	3-36
<b>3.8</b>	<b>Tools menu .....</b>	<b>3-38</b>
3.8.1	ASUS O.C. Profile.....	3-38
3.8.2	AI NET 2.....	3-39
3.8.3	ASUS EZ Flash 2.....	3-40
3.8.4	Express Gate .....	3-40
<b>3.9</b>	<b>Exit menu .....</b>	<b>3-42</b>
 <b>Chapter 4: Software support</b>		
<b>4.1</b>	<b>Installing an operating system .....</b>	<b>4-1</b>
<b>4.2</b>	<b>Support DVD information .....</b>	<b>4-1</b>
4.2.1	Running the support DVD .....	4-1
4.2.2	Drivers menu.....	4-2
4.2.3	Utilities menu .....	4-4
4.2.4	Make disk menu.....	4-5
4.2.5	Manual menu .....	4-6
4.2.6	ASUS Contact information .....	4-6
4.2.7	Other information .....	4-7
<b>4.3</b>	<b>Software information .....</b>	<b>4-9</b>
4.3.1	ASUS PC Probe II.....	4-9
4.3.2	ASUS AI Suite.....	4-15
4.3.3	ASUS Fan Xpert .....	4-17
4.3.4	ASUS EPU-6 Engine .....	4-18
4.3.5	ASUS Express Gate .....	4-19
4.3.6	ASUS T.Probe.....	4-21
<b>4.4</b>	<b>ASUS Unique Overclocking Utility – TurboV EVO.....</b>	<b>4-22</b>
4.4.1	Using ASUS TurboV.....	4-22
4.4.2	Using ASUS TurboV Auto Tuning Mode.....	4-23
<b>4.5</b>	<b>ASUS GPU Boost .....</b>	<b>4-26</b>

# Contents

<b>4.6</b>	<b>RAID configurations .....</b>	<b>4-27</b>
4.6.1	RAID definitions .....	4-27
4.6.2	Installing Serial ATA hard disks .....	4-28
4.6.3	Setting the RAID item in BIOS .....	4-28
4.6.4	Intel® Matrix Storage Manager option ROM utility .....	4-28
<b>4.</b>	<b>Creating a RAID driver disk.....</b>	<b>4-32</b>
4.7.1	Creating a RAID driver disk without entering the OS....	4-32
4.7.2	Creating a RAID driver disk in Windows® .....	4-32
4.7.3	Installing the RAID driver during Windows® OS installation.....	4-33
4.7.4	Using a USB floppy disk drive.....	4-33
 <b>Chapter 5: Multiple GPU technology support</b>		
<b>5.1</b>	<b>ATI® CrossFireX™ technology .....</b>	<b>5-1</b>
5.1.1	Requirements.....	5-1
5.1.2	Before you begin.....	5-1
5.1.3	Installing CrossFireX graphics cards .....	5-2
5.1.4	Installing the device drivers.....	5-3
5.1.5	Enabling the ATI® CrossFireX™ technology .....	5-3
<b>5.2</b>	<b>NVIDIA® SLI™ technology .....</b>	<b>5-5</b>
5.2.1	Requirements.....	5-5
5.2.2	Installing two SLI-ready graphics cards .....	5-6
5.2.3	Installing three SLI-ready graphics cards.....	5-7
5.2.4	Installing the device drivers.....	5-8
5.2.5	Enabling the NVIDIA® SLI™ technology .....	5-8
<b>5.3</b>	<b>NVIDIA® CUDA™ technology .....</b>	<b>5-11</b>
5.3.1	Requirements.....	5-11
5.3.2	Installing CUDA-ready graphics cards .....	5-11

# Notices

## Federal Communications Commission Statement

This device complies with Part 15 of the FCC Rules. Operation is subject to the following two conditions:

- This device may not cause harmful interference, and
- This device must accept any interference received including interference that may cause undesired operation.

This equipment has been tested and found to comply with the limits for a Class B digital device, pursuant to Part 15 of the FCC Rules. These limits are designed to provide reasonable protection against harmful interference in a residential installation. This equipment generates, uses and can radiate radio frequency energy and, if not installed and used in accordance with manufacturer's instructions, may cause harmful interference to radio communications. However, there is no guarantee that interference will not occur in a particular installation. If this equipment does cause harmful interference to radio or television reception, which can be determined by turning the equipment off and on, the user is encouraged to try to correct the interference by one or more of the following measures:

- Reorient or relocate the receiving antenna.
- Increase the separation between the equipment and receiver.
- Connect the equipment to an outlet on a circuit different from that to which the receiver is connected.
- Consult the dealer or an experienced radio/TV technician for help.



---

The use of shielded cables for connection of the monitor to the graphics card is required to assure compliance with FCC regulations. Changes or modifications to this unit not expressly approved by the party responsible for compliance could void the user's authority to operate this equipment.

---

## Canadian Department of Communications Statement

This digital apparatus does not exceed the Class B limits for radio noise emissions from digital apparatus set out in the Radio Interference Regulations of the Canadian Department of Communications.

This class B digital apparatus complies with Canadian ICES-003.

## REACH

Complying with the REACH (Registration, Evaluation, Authorization, and Restriction of Chemicals) regulatory framework, we published the chemical substances in our products at ASUS website at <http://green.asus.com/english/REACH.htm>.

# Safety information

## Electrical safety

- To prevent electrical shock hazard, disconnect the power cable from the electrical outlet before relocating the system.
- When adding or removing devices to or from the system, ensure that the power cables for the devices are unplugged before the signal cables are connected. If possible, disconnect all power cables from the existing system before you add a device.
- Before connecting or removing signal cables from the motherboard, ensure that all power cables are unplugged.
- Seek professional assistance before using an adapter or extension cord. These devices could interrupt the grounding circuit.
- Ensure that your power supply is set to the correct voltage in your area. If you are not sure about the voltage of the electrical outlet you are using, contact your local power company.
- If the power supply is broken, do not try to fix it by yourself. Contact a qualified service technician or your retailer.

## Operation safety

- Before installing the motherboard and adding devices on it, carefully read all the manuals that came with the package.
- Before using the product, ensure all cables are correctly connected and the power cables are not damaged. If you detect any damage, contact your dealer immediately.
- To avoid short circuits, keep paper clips, screws, and staples away from connectors, slots, sockets and circuitry.
- Avoid dust, humidity, and temperature extremes. Do not place the product in any area where it may become wet.
- Place the product on a stable surface.
- If you encounter technical problems with the product, contact a qualified service technician or your retailer.



---

**DO NOT** throw the motherboard in municipal waste. This product has been designed to enable proper reuse of parts and recycling. This symbol of the crossed out wheeled bin indicates that the product (electrical and electronic equipment) should not be placed in municipal waste. Check local regulations for disposal of electronic products.

---



---

**DO NOT** throw the mercury-containing button cell battery in municipal waste. This symbol of the crossed out wheeled bin indicates that the battery should not be placed in municipal waste.

---

## About this guide

This user guide contains the information you need when installing and configuring the motherboard.

## How this guide is organized

This guide contains the following parts:

- **Chapter 1: Product introduction**  
This chapter describes the features of the motherboard and the new technology it supports.
- **Chapter 2: Hardware information**  
This chapter lists the hardware setup procedures that you have to perform when installing system components. It includes description of the switches, jumpers, and connectors on the motherboard.
- **Chapter 3: BIOS setup**  
This chapter tells how to change system settings through the BIOS Setup menus. Detailed descriptions of the BIOS parameters are also provided.
- **Chapter 4: Software support**  
This chapter describes the contents of the support DVD that comes with the motherboard package and the software.
- **Chapter 5: Multiple GPU technology support**  
This chapter describes how to install and configure multiple ATI® CrossFireX™ and NVIDIA® SLI™ graphics cards.

## Where to find more information

Refer to the following sources for additional information and for product and software updates.

1. **ASUS websites**  
The ASUS website provides updated information on ASUS hardware and software products. Refer to the ASUS contact information.
2. **Optional documentation**  
Your product package may include optional documentation, such as warranty flyers, that may have been added by your dealer. These documents are not part of the standard package.

## Conventions used in this guide

To ensure that you perform certain tasks properly, take note of the following symbols used throughout this manual.



**DANGER/WARNING:** Information to prevent injury to yourself when trying to complete a task.



**CAUTION:** Information to prevent damage to the components when trying to complete a task.



**IMPORTANT:** Instructions that you **MUST** follow to complete a task.



**NOTE:** Tips and additional information to help you complete a task.

## Typography

### **Bold text**

Indicates a menu or an item to select.

### *Italics*

Used to emphasize a word or a phrase.

### <Key>

Keys enclosed in the less-than and greater-than sign means that you must press the enclosed key.

Example: <Enter> means that you must press the Enter or Return key.

### <Key1+Key2+Key3>

If you must press two or more keys simultaneously, the key names are linked with a plus sign (+).

Example: <Ctrl+Alt+D>

### **Command**

Means that you must type the command exactly as shown, then supply the required item or value enclosed in brackets.

Example: At the DOS prompt, type the command line:

```
BUPDATER /iP7F7EWSSC.ROM
```

# P7F7-E WS Supercomputer specifications summary

<b>CPU</b>	LGA 1156 socket for Intel® Core™ i7/Core™ i5/Core™ i3/ Pentium® desktop Processors LGA 1156 socket for Intel 3400 series server processor * The Intel Turbo Boost Technology support depends on the CPU types. ** Refer to <a href="http://www.asus.com">www.asus.com</a> for Intel CPU support list
<b>Chipset</b>	Intel® 3450 Chipset Nvidia NF200*1
<b>Memory</b>	6 x DIMM, max. 16GB, DDR3 2000(O.C.)* /1333 /1066/ 800 MHz, non-ECC/ECC, un-buffered memory Dual channel architecture Support Intel Extreme Memory Profile (XMP) * Due to Intel spec definition, DIMMs of DDR3-1333 or above are supported by specific CPU models only. * Please load X.M.P in BIOS for hyper DIMM (DDR3 1333MHz or above) support.
<b>On-board VGA</b>	Multi-VGA output support: DVI-I and RGB ports Supports DVI with max. resolution 1920 x 1200 @ 60Hz Supports RGB with max. resolution 2048 x 1536 @ 75 Hz Maximum shared memory of 1748 MB
<b>Expansion Slots</b>	2 x PCIe 2.0 x16 (@ x16 or x8) 2 x PCIe 2.0 x16 (@ x8) 3 x PCIe x1 (@ x1)
<b>Multi-GPU Technology</b>	Supports NVIDIA® Geforce 3 way/2 way SLI™ technology Supports ATI® CrossFireX™ technology, up to Quad CrossFireX™
<b>CUDA support</b>	Up to 3 NVIDIA Tesla cards + 1 NVIDIA Quadro card Up to 4 NVIDIA Tesla cards (only for Clarkdale processor)
<b>Storage</b>	Intel® 3450 Chipset - 6 x SATA 150/300 - Intel® Matrix Storage supporting SATA RAID 0, 1, 10, and 5 Marvell® PCIe SATA6Gb/s controller: - 2 x SATA 6.0 Gb/s ports - Support SATA RAID 0 and 1
<b>LAN</b>	2 x Realtek 81112L Dual Gb LAN - Support teaming function
<b>USB</b>	NEC USB 3.0 controller - 2 x USB 3.0 ports (Blue, at back panel) Intel® 3450 Ibx Peak - 12 x USB 2.0 ports (6 ports at mid-board, 6 ports at back panel)

(continued on the next page)



# P7F7-E WS Supercomputer specifications summary

1394	LSI FW643E-02 controller supports 2 x 1394b ports and 1 x 1394a port
Audio	VIA VT2020, 10 channels High Definition Audio CODEC Multi-Streaming Jack-Sensing Front Panel Jack-Retasking Optical S/PDIF out ports at back I/O ASUS Noise-Filer
ASUS Special Features	ASUS Xtreme Design  ASUS Exclusive Overclocking Features - GPU Boost - TurboV EVO and Turbo Key  ASUS Xtreme Phase - 16+3 Phase Power Design  ASUS Exclusive Features - Express Gate - MemOK! - ASUS EPU  ASUS Quiet Thermal Solution - ASUS Fanless Design: Stack Cool 3+ - ASUS Fan Xpert  ASUS EZ DIY - ASUS Q-DIMM - ASUS Q-Connector - ASUS O.C. Profile - ASUS CrashFree BIOS 3 - ASUS EZ Flash 2 - ASUS MyLogo 2 - Multi-language BIOS
Workstation Unique Features	4 x PCIe x16 slots G.P. Diagnosis Card bundled Quick Gate:2 vertical USB 2.0 on board ASUS SASsaby series Cards support ASUS WS Diag. LED ASUS WS Heartbeat
BIOS Features	64 Mb flash ROM, AMI BIOS, Green, PnP, DMI v2.0, ACPI v2.0a, SMBIOS v 2.6; WOL/WOR by PME

(continued on the next page)

# P7F7-E WS Supercomputer specifications summary

<b>Back Panel I/O Ports</b>	PS/2 KB/MS port S/PDIF Out (Optical) 4 x USB 2.0/1.1 ports 2 x USB 3.0/2.0 ports 1 x IEEE1394a 2 x IEEE1394b 2 x LAN Connector 1 x DVI-I port 1 x 10-channel Audio I/O
<b>Internal I/O Connectors</b>	24-pin EATX Power connector 8-pin EATX +12V Power connector 4pin EZ_PLUG Power connector CPU fan with PWM control Chassis fan1 with Q-fan control Chassis fan2 with Q-fan control Chassis fan3 with Q-fan control PWR fan CD audio in 1 x AAFP connector 1 x COM port connector 3 x USB connectors support additional 6 USB ports 2 x USB 2.0/1.1 ports TPM header S/PDIF Out header 1 x MemOK! Button 20-pinfront panel connector
<b>Manageability</b>	WfM 2.0, DMI 2.0, WOL by PME, WOR by PME, PXE
<b>Form Factor</b>	ATX Form Factor, 12"x 9.6"(30.5cm x 24.5cm)

**\*Specifications are subject to change without notice.**

This chapter describes the motherboard features and the new technologies it supports.

# 1 Product introduction

# Chapter summary



- 1.1 Welcome! ..... 1-1
- 1.2 Package contents..... 1-1
- 1.3 Special features..... 1-2

## 1.1 Welcome!

Thank you for buying an ASUS P7F7-E WS Supercomputer motherboard!

The motherboard delivers a host of new features and latest technologies, making it another standout in the long line of ASUS quality motherboards!

Before you start installing the motherboard, and hardware devices on it, check the items in your package with the list below.

## 1.2 Package contents

Check your motherboard package for the following items.

Motherboard	ASUS P7F7-E WS Supercomputer
I/O modules	1 x 2-port USB 2.0 module
Cables	2 x Serial ATA 6.0 Gb/s signal cables 2 x Serial ATA power cables 6 x Serial ATA signal cables 1 x COM port cable
Accessories	1 x ASUS Q-Shield (I/O shield) 1 x ASUS Q-Connector Kit (USB, system panel; Retail version only) 1 x G.P. Diagnosis Card (Retail version only) 1 x ASUS SLI bridge 1 x ASUS 3-Way SLI bridge card
Application DVD	ASUS motherboard support DVD
Documentation	User guide



If any of the above items is damaged or missing, contact your retailer.

## 1.3 Special features

### 1.3.1 Product highlights

#### Green ASUS

This motherboard and its packaging comply with the European Union's Restriction on the use of Hazardous Substances (RoHS). This is in line with the ASUS vision of creating environment-friendly and recyclable products/packagings to safeguard consumers' health while minimizing the impact on the environment.

#### Intel® LGA1156 Clarkdale/Lynnfield Processor Ready

This motherboard supports the latest Intel® Clarkdale/Lynnfield processors in LGA1156 package, which has memory and PCI Express controller integrated to support 2-channel (6 DIMMs) DDR3 memory and 16 PCI Express 2.0 lanes, providing great graphics performance. Intel® Clarkdale/Lynnfield processor is one of the most powerful and energy efficient CPU in the world.

#### Intel® 3450 Ixex Peak

The Intel® 3450 Express Chipset is the latest one-chipset design to support the latest 1156 socket Intel® Core™ i7 / Core™ i5 / Core™ i3/ Pentium® processors. Intel 3450 provides improved performance by utilizing serial point-to-point links, allowing increased bandwidth and stability.

#### PCIe 2.0

##### *Double Speed; Double Bandwidth*

This motherboard supports the latest PCIe 2.0 devices for double speed and bandwidth that enhances system performance.

#### Dual-Channel DDR3 2000(O.C.) / 1600 / 1333 / 1066 / 800 support

The motherboard supports DDR3 memory that features data transfer rates of 2000(O.C.) / 1600 / 1333 / 1066 / 800 MHz to meet the higher bandwidth requirements of the latest 3D graphics, multimedia, and Internet applications. The dual-channel DDR3 architecture enlarges the bandwidth of your system memory to boost system performance.



---

The Clarkdale CPU supports memory data transfer rate up to 1600 (O.C.) and the Lynnfield CPU supports memory data transfer rate to 2000 (O.C.).

---

#### SATA 6Gb/s Support

##### **Experience the Future of Storage!**

Supporting next-generation Serial ATA (SATA) storage interface, this motherboard delivers up to 6.0Gb/s data transfer rates. Additionally, get enhanced scalability, faster data retrieval, double the bandwidth of current bus systems.

## **USB 3.0 Support**

### **10X Faster Data Rates!**

Experience ultra-fast data transfers at 4.8Gbps with USB 3.0—the latest connectivity standard. Built to connect easily with next generation components and peripherals, USB 3.0 transfers data 10X faster and is also backward compatible with USB 2.0 components.

## **1.3.2 ASUS Xtreme Design—Hybrid Processor**

### **TurboV EVO**

#### ***Ultimate O.C. Processor***

The ultimate O.C. processor satisfies every level of overclockers—from die-hard enthusiasts to beginners. Auto tuning intelligently pushes the system to the fastest clock speeds while maintaining stability. Turbo Key boosts performance with just one touch; while TurboV offers more options to advanced overclockers to achieve world O.C. record.

### **Auto Tuning**

#### ***Auto System Level Up***

Auto Tuning is an intelligent tool that automates overclocking to achieve a total system level up. This tool also provides stability testing. Even O.C. beginners can achieve extreme yet stable overclocking results with Auto Tuning!

## **1.3.3 ASUS Hybrid Phase**

### **T.Probe**

#### ***Leading Active Cooling Technology***

The T.Probe microchip detects and balances power phase loading and temperature in real-time. This feature optimizes the power phase functions, allowing components to run at lower temperatures and extending their lifespan.

### **16+3 Phase Power Design**

#### ***Unprecedented Innovation with the Best Quality Component for Best Performance***

The groundbreaking 16+3 phase VRM design is brought to the ASUS motherboards. 16+3 phase power design, 16-phase for vCore and extra 3-phase for Memory controller inside CPU can provide the highest power efficiency, and hence generates less heat to effectively enhance the overclocking capability. With the high quality power components such as low RDS (on) MOSFETs, Ferrite core chokes with lower hysteresis loss and 100% Japan-made high quality conductive polymer capacitors, ASUS 16+3 phase VRM design also ensure longer component life and minimum power loss.

## 1.3.4 ASUS Hybrid OS

### Express Gate

#### *Instant Online! Instant Fun!*

Express Gate is an ASUS exclusive OS that provides you with quick access to the Internet and key applications before entering the Windows® OS.

## 1.3.5 ASUS Exclusive Features

### MemOK!

#### *Any Memory is A-OK!*

Memory compatibility is among the top concerns during computer upgrades. Worry no more. MemOK! is the fastest memory booting solution today. This remarkable memory rescue tool requires nothing but a push of a button to patch memory issues and get your system up and running in no time. The technology is able to determine failsafe settings that can dramatically improve your system booting success.

### ASUS EPU

#### *System Level Energy Saving*

The new ASUS EPU—the world's first power saving engine, has been upgraded to a new 6 engine version, which provides total system power savings by detecting current PC loadings and intelligently moderating power in real-time. With auto phase switching for components (which includes the CPU, VGA card, memory, chipset, hard drives and CPU cooler / system fans), the EPU automatically provides the most appropriate power usage via intelligent acceleration and overclocking—helping save power and money.

### ASUS Quiet Thermal Solution

ASUS Quiet Thermal solution makes system more stable and enhances the overclocking capability.

#### **ASUS Fanless Design—Heat-pipe solution**

The Heat Pipe design effectively directs the heat generated by the vCore area to the heatsink near the back IO ports, where it can be carried away by existing airflow from CPU fan. The purpose of the innovative heat pipe design on this motherboard is that the groundbreaking fanless design does not have lifetime problems as a chipset fan does. The Heat Pipe design is the most reliable fanless thermal solution to date.



---

DO NOT uninstall the heat-pipe by yourself. Doing so may bend the tubing and affect the heat dissipation performance.

---



## **Fan Xpert**

### ***Active Quiet & Cool***

ASUS Fan Xpert intelligently allows users to adjust both the CPU and chassis fan speed according to different ambient temperature, which is caused by different climate conditions in different geographic regions and system loading. Built-in variety of useful profiles offer flexible controls of fan speed to achieve a quiet and cool environment.

## **ASUS Crystal Sound**

This feature can enhance speech-centric applications like Skype, online game, video conference and recording.

### **ASUS Noise Filter**

#### ***Eliminate background noise while recording***

This feature detects repetitive and stationary noises like computer fans, air conditioners, and other background noises then eliminates it in the incoming audio stream while recording.

### **DTS**

#### ***DTS Surround Sensation UltraPC***

DTS Surround Sensation UltraPC delivers exceptional 5.1 surround experience through the most common PC audio setups—your existing stereo speakers or headphones. In addition to virtual surround, “Bass enhancement” provides stronger low frequency bass sound, and “Voice clarification” provides clear human dialogue even with loud background sound. With these technologies, you may experience a better home-theater audio with ease.

## **ASUS EZ DIY**

ASUS EZ DIY feature collection provides you easy ways to install computer components, update the BIOS or back up your favorite settings.

### **ASUS Onboard Switch**

With an easy press during overclocking, the exclusive onboard switches allow gamers to effortless fine-tune the performance without having to short the pins!

### **ASUS Q-Design**

#### ***DIY quickly, DIY easily!***

ASUS Q-Design enhances your DIY experience. All of Q-LED, Q-DIMM, and Q-Slot design speed up and simplify the DIY process!

### **ASUS CrashFree BIOS 3**

The ASUS CrashFree BIOS 3 allows users to restore corrupted BIOS data from a USB flash disk containing the BIOS file.

### **ASUS Q-Connector**

#### ***Make connection quick and accurate!***

The ASUS Q-Connector allows you to connect or disconnect chassis front panel cables in one easy step with one complete module. This unique module eliminates the trouble of plugging in one cable at a time, making connection quick and accurate.

### **ASUS EZ-Flash 2**

#### ***Simply update BIOS from a USB flash drive before entering the OS***

EZ Flash 2 is a user-friendly BIOS update utility. Simply launch this tool and update BIOS from a USB flash drive before entering the OS. You can update your BIOS only in a few clicks without preparing an additional floppy diskette or using an OS-based flash utility.

### **ASUS O.C. Profile**

#### ***Conveniently restore or load multiple BIOS settings***

Freely share and distribute favorite overclocking settings. The motherboard features the ASUS O.C. Profile that allows users to conveniently store or load multiple BIOS settings. The BIOS settings can be stored in the CMOS or a separate file, giving users freedom to share and distribute their favorite overclocking settings.

### **ASUS MyLogo2™**

This feature allows you to convert your favorite photo into a 256-color boot logo for a more colorful and vivid image on your screen.

### **ASUS Multi-language BIOS**

The multi-language BIOS allows you to select the language of your choice from the available options. The localized BIOS setup menu helps you configure your system easier and faster.

This chapter lists the hardware setup procedures that you have to perform when installing system components. It includes description of the jumpers and connectors on the motherboard.

# Hardware 2 information

2.1	Before you proceed .....	2-1
2.2	Motherboard overview.....	2-2
2.3	Central Processing Unit (CPU) .....	2-5
2.4	System memory .....	2-11
2.5	Expansion slots.....	2-28
2.6	Jumper .....	2-31
2.7	Connectors .....	2-32
2.8	Onboard LEDs.....	2-48
2.9	Starting up for the first time.....	2-49
2.10	Turning off the computer.....	2-50

## 2.1 Before you proceed

Take note of the following precautions before you install motherboard components or change any motherboard settings.



- 
- Unplug the power cord from the wall socket before touching any component.
  - Use a grounded wrist strap or touch a safely grounded object or a metal object, such as the power supply case, before handling components to avoid damaging them due to static electricity.
  - Hold components by the edges to avoid touching the ICs on them.
  - Whenever you uninstall any component, place it on a grounded antistatic pad or in the bag that came with the component.
  - Before you install or remove any component, ensure that the ATX power supply is switched off or the power cord is detached from the power supply. Failure to do so may cause severe damage to the motherboard, peripherals, and/or components.
-

## 2.2 Motherboard overview

### 2.2.1 Motherboard layout

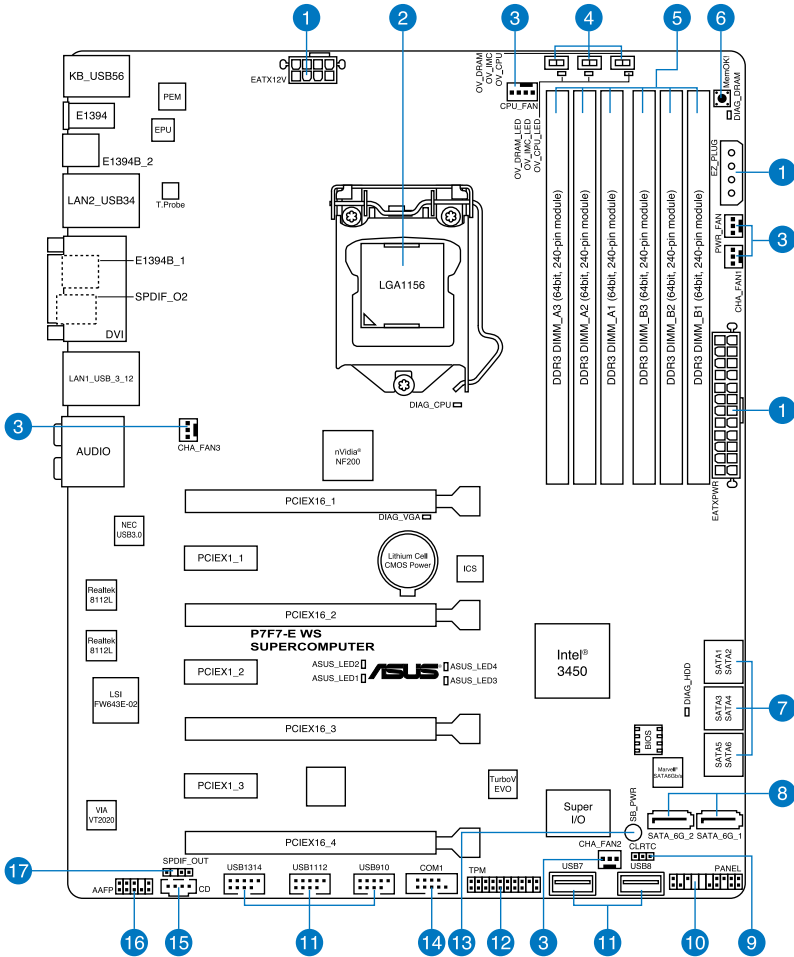

## 2.2.2 Layout contents

Connectors/Jumpers/Switches/Slots		Page
1.	Power connectors (24-pin EATXPWR, 8-pin EATX12V, 4-pin EZ_PLUG)	2-43
2.	LGA1156 CPU Socket	2-6
3.	CPU, chassis, and power fan connectors (4-pin CPU_FAN, 3-pin CHA_FAN1-3, 3-pin PWR_FAN)	2-42
4.	CPU / IMC / DRAM overvoltage setting switches (OV_DRAM; OV_IMC; OV_CPU)	2-47
5.	DDR3 DIMM slots	2-11
6.	MemOK! switch	2-46
7.	Serial ATA 3.0 Gb/s connectors (7-pin SATA 1-6)	2-37
8.	Marvell® Serial ATA 6.0 Gb/s connectors (7-pin STAT_6G_1/2)	2-38
9.	Clear RTC RAM (3-pin CLRTC)	2-31
10.	System panel connector (20-8 pin PANEL)	2-44
11.	USB connectors and ports (10-1 pin 10-1 pin USB910, USB1112, USB1314; A-Type USB7, USB8)	2-39
12.	TPM connector (20-1 pin TPM)	2-42
13.	Standby Power LED	2-48
14.	Serial port connector (10-1 pin COM1)	2-40
15.	Optical drive audio connector (4-pin CD)	2-41
16.	Front panel audio connector (10-1 pin AAFP)	2-41
17.	Digital audio connector (4-1 pin SPDIF_OUT)	2-40



Refer to **2.7 Connectors** for more information about rear panel connectors and internal connectors.

### 2.2.3 Placement direction

When installing the motherboard, ensure that you place it into the chassis in the correct orientation. The edge with external ports goes to the rear part of the chassis as indicated in the image below.

### 2.2.4 Screw holes

Place nine (9) screws into the holes indicated by circles to secure the motherboard to the chassis.



DO NOT overtighten the screws! Doing so can damage the motherboard.

Place this side towards the rear of the chassis

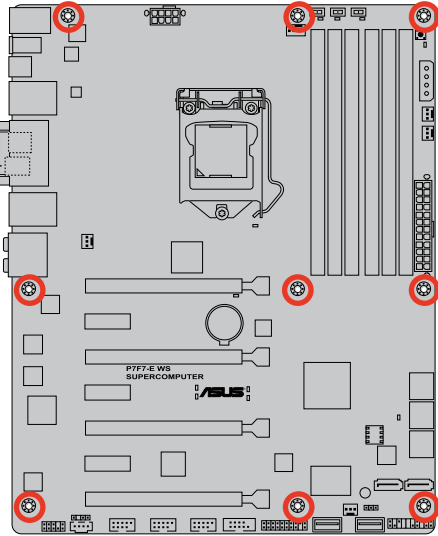



## 2.3 Central Processing Unit (CPU)

The motherboard comes with a surface mount LGA1156 socket designed for the Intel® Core™ i3/i5/i7 Processor.



- 
- Ensure that all power cables are unplugged before installing the CPU.
  - Connect the chassis fan cable to the CHA\_FAN3 connector to ensure system stability.
- 



- 
- Upon purchase of the motherboard, ensure that the PnP cap is on the socket and the socket contacts are not bent. Contact your retailer immediately if the PnP cap is missing, or if you see any damage to the PnP cap/socket contacts/motherboard components. ASUS will shoulder the cost of repair only if the damage is shipment/transit-related.
  - Keep the cap after installing the motherboard. ASUS will process Return Merchandise Authorization (RMA) requests only if the motherboard comes with the cap on the LGA1156 socket.
  - The product warranty does not cover damage to the socket contacts resulting from incorrect CPU installation/removal, or misplacement/loss/incorrect removal of the PnP cap.
-

### 2.3.1 Installing the CPU

To install a CPU:

1. Locate the CPU socket on the motherboard.

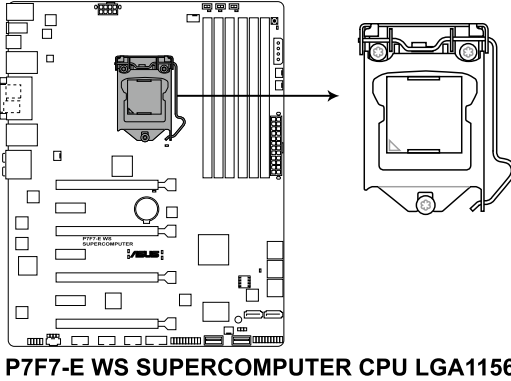

**P7F7-E WS SUPERCOMPUTER CPU LGA1156**

2. Press the load lever with your thumb (A), and then move it to the right (B) until it is released from the retention tab.



To prevent damage to the socket pins, do not remove the PnP cap unless you are installing a CPU.

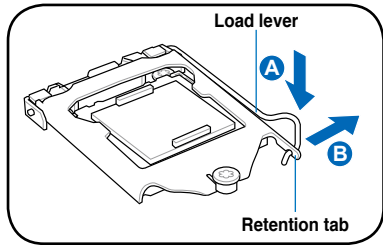

3. Lift the load lever in the direction of the arrow until the load plate is completely lifted.

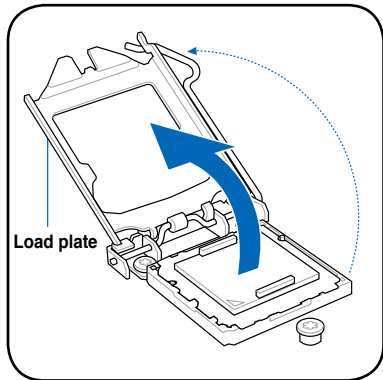

4. Remove the PnP cap from the CPU socket.

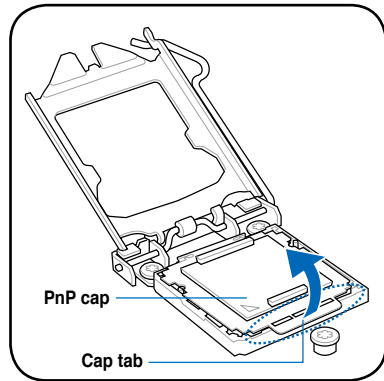

5. Position the CPU over the socket, ensuring that the gold triangle is on the bottom-left corner of the socket, and then fit the socket alignment keys into the CPU notches.



The CPU fits in only one correct orientation. **DO NOT** force the CPU into the socket to prevent bending the connectors on the socket and damaging the CPU!

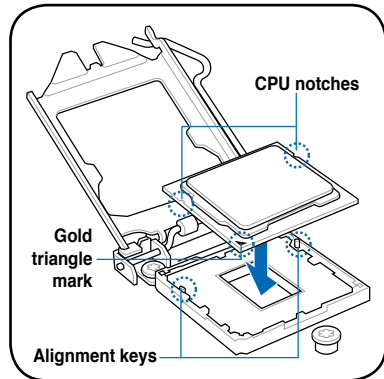

6. Apply some Thermal Interface Material to the exposed area of the CPU that the heatsink will be in contact with, ensuring that it is spread in an even thin layer.



Some heatsinks come with pre-applied thermal interface material. If so, skip this step.



The Thermal Interface Material is toxic and inedible. **DO NOT** eat it. If it gets into your eyes or touches your skin, wash it off immediately, and seek professional medical help.

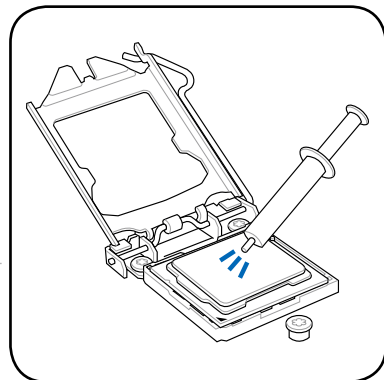

7. Close the load plate (A), and then push down the load lever (B), ensuring that the front edge of the load plate slides under the retention knob (C).

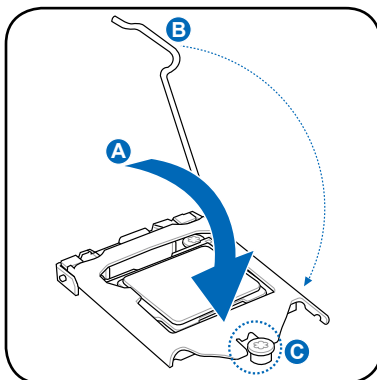

8. Insert the load lever under the retention tab.

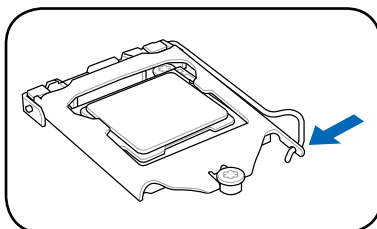

### 2.3.2 Installing the CPU heatsink and fan

The Intel® LGA1156 processor requires a specially designed heatsink and fan assembly to ensure optimum thermal condition and performance.



- When you buy a boxed Intel® processor, the package includes the CPU fan and heatsink assembly. If you buy a CPU separately, ensure that you use only Intel®-certified multi-directional heatsink and fan.
- Your Intel® LGA1156 heatsink and fan assembly comes in a push-pin design and requires no tool to install.
- Use an LGA1156-compatible CPU heatsink and fan assembly only. The LGA1156 socket is incompatible with the LGA775 and LGA1366 sockets in size and dimension.



If you purchased a separate CPU heatsink and fan assembly, ensure that the Thermal Interface Material is properly applied to the CPU heatsink or CPU before you install the heatsink and fan assembly.



Ensure that you have installed the motherboard to the chassis before you install the CPU fan and heatsink assembly.

To install the CPU heatsink and fan:

1. Place the heatsink on top of the installed CPU, ensuring that the four fasteners match the holes on the motherboard.
2. Push down two fasteners at a time in a diagonal sequence to secure the heatsink and fan assembly in place.

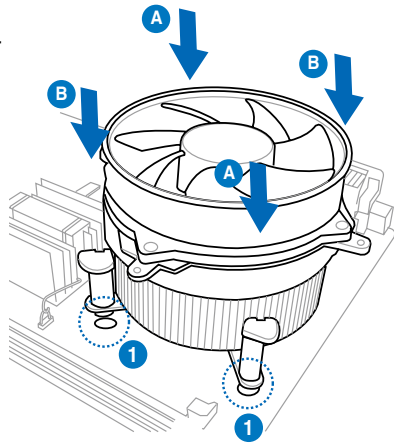
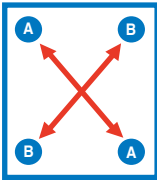

Orient the heatsink and fan assembly such that the CPU fan cable is closest to the CPU fan connector.

3. Connect the CPU fan cable to the connector on the motherboard labeled CPU\_FAN.

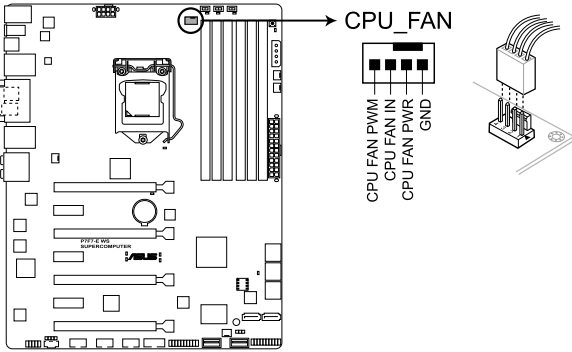

**P7F7-E WS SUPERCOMPUTER CPU fan connector**



DO NOT forget to connect the CPU fan connector! Hardware monitoring errors can occur if you fail to plug this connector.

### 2.3.3 Uninstalling the CPU heatsink and fan

To uninstall the CPU heatsink and fan:

1. Disconnect the CPU fan cable from the connector on the motherboard.
2. Rotate each fastener counterclockwise.
3. Pull up two fasteners at a time in a diagonal sequence to disengage the heatsink and fan assembly from the motherboard.

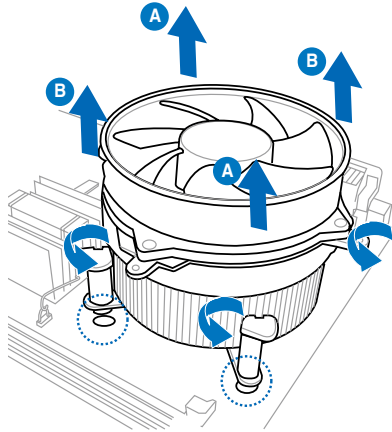
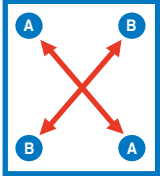

4. Carefully remove the heatsink and fan assembly from the motherboard.

## 2.4 System memory

### 2.4.1 Overview

The motherboard comes with six Double Data Rate 3 (DDR3) Dual Inline Memory Modules (DIMM) sockets.

A DDR3 module has the same physical dimensions as a DDR2 DIMM but is notched differently to prevent installation on a DDR2 DIMM socket. DDR3 modules are developed for better performance with less power consumption.

The figure illustrates the location of the DDR3 DIMM sockets:

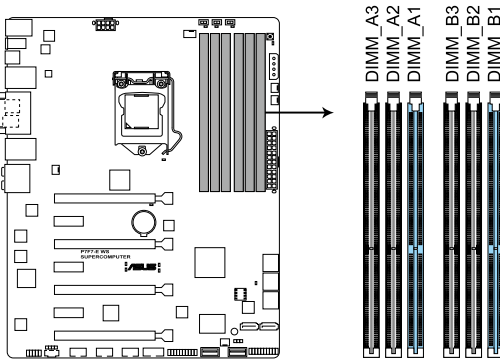

**P7F7-E WS SUPERCOMPUTER 240-pin DDR3 DIMM sockets**

### Memory population configuration

Dual Channel Memory configuration table for Lynnfield CPU						
	A3	A2	A1	B3	B2	B1
1 DIMM	—	—	—	—	—	SS/DS
1 DIMM	—	—	SS/DS	—	—	—
2 DIMMs	—	—	SS/DS	—	—	SS/DS
4 DIMMs	—	SS/DS	SS/DS	—	SS/DS	SS/DS
4 DIMMs	DS	—	DS	DS	—	DS
6 DIMMs	SS	SS	SS	SS	SS	SS

(SS = Single-sided; DS = Double sided; "—" = No memory)

Dual Channel Memory configuration table for Clarkdale CPU

	A3	A2	A1	B3	B2	B1
1 DIMM	—	—	—	—	—	SS/DS
1 DIMM	—	—	SS/DS	—	—	—
1 DIMMs	—	—	—	—	SS/DS	—
1 DIMMs	—	SS/DS	—	—	—	—
2 DIMMs	—	—	SS/DS	—	—	SS/DS
2 DIMMs	—	SS/DS	—	—	SS/DS	—
4 DIMMs	—	SS/DS	SS/DS	—	SS/DS	SS/DS

(SS = Single-sided; DS = Double sided; “—” = No memory)



## 2.4.2 Memory configurations

You may install 512MB, 1GB, 2GB and 4GB (total maximum 16GB) ECC and non-ECC unbuffered DDR3 DIMMs into the DIMM sockets.



- 
- You may install varying memory sizes in Channel A and Channel B. The system maps the total size of the lower-sized channel for the dual-channel configuration. Any excess memory from the higher-sized channel is then mapped for single-channel operation.
  - Due to Intel spec definition, X.M.P. DIMMs and DDR3-1600 are supported for one DIMM per channel only.
  - According to Intel CPU spec, DIMMs with voltage requirement over 1.65V may damage the CPU permanently. We recommend you install the DIMMs with the voltage requirement below 1.65V.
  - Always install DIMMs with the same CAS latency. For optimum compatibility, we recommend that you obtain memory modules from the same vendor.
  - Due to the memory address limitation on 32-bit Windows OS, when you install 4GB or more memory on the motherboard, the actual usable memory for the OS can be about 3GB or less. For effective use of memory, we recommend that you do any of the following:
    - Use a maximum of 3GB system memory if you are using a 32-bit Windows OS.
    - Install a 64-bit Windows OS when you want to install 4GB or more on the motherboard.For more details, refer to the Microsoft® support site at <http://support.microsoft.com/kb/929605/en-us>.
- 



- 
- The default memory operation frequency is dependent on its Serial Presence Detect (SPD), which is the standard way of accessing information from a memory module. Under the default state, some memory modules for overclocking may operate at a lower frequency than the vendor-marked value. To operate at the vendor-marked or at a higher frequency, refer to section **3.6 Advanced menu** for manual memory frequency adjustment.
  - For system stability, use a more efficient memory cooling system to support a full memory load (6 DIMMs) or overclocking condition.
-

## Lynnfield CPU

### P7F7-E WS Supercomputer Motherboard

#### Qualified Vendors Lists (QVL) DDR3-2000MHz capability

Part No.	Size	SS/DS	Timing	Voltage	DIMM socket support (Optional)			
					2	4	6	
CORSAIR	CMG4GX3M2A2000C8(XMP)	4GB(2 x 2GB)	DS	8-8-8-24	1.65	•		
Crucial	BL12864BE2009.8SFB3(EPP)	1GB	SS	9-9-9-28	2	•		
G.SKILL	F3-16000CL9D-4GBRH(XMP)	4GB(2 x 2GB)	DS	9-9-9-24	1.65	•		
G.SKILL	F3-16000CL9D-4GBTD(XMP)	4GB(2 x 2GB)	DS	9-9-9-24	1.65	•		
G.SKILL	F3-16000CL9T-6GBPS(XMP)	6GB(3 x 2GB)	DS	9-9-9-24	1.65	•		
GEIL	GU34GB2000C9DC(XMP)	4GB(2 x 2GB)	DS	9-9-9-28	2	•		
GEIL	GU34GB2000C9DC(XMP)	4GB(2 x 2GB)	DS	9-9-9-28	1.65	•		
GEIL	GE38GB2000C9QC(XMP)	8GB(4 x 2GB)	DS	9-9-9-28	1.65	•		
KINGSTON	KHX2000C8D3T1K3/3GX(XMP)	3GB(3 x 1GB)	SS	8	1.65	•		
KINGSTON	KHX2000C9D3T1K3/3GX(XMP)	3GB(3 x 1GB)	SS	9	1.65	•		
OCZ	OCZ3P20002GK(EPP)	2GB(2 x 1GB)	SS	9	1.9	•		
OCZ	OCZ3P2000EB2GK	2GB(2 x 1GB)	SS	9-8-8	1.8	•		
OCZ	OCZ3B2000LV6GK	6GB(3 x 2GB)	DS	7-8-7	1.65	•		
Patriot	PVT36G2000LLK(XMP)	6GB(3 x 2GB)	DS	8-8-8-24	1.65	•		

### P7F7-E WS Supercomputer Motherboard

#### Qualified Vendors Lists (QVL) DDR3-1866MHz capability

Part No.	Size	SS/DS	Timing	Voltage	DIMM socket support (Optional)			
					2	4	6	
CORSAIR	TR3X6G1866C9DVer4.1(XMP)	6GB(3 x 2GB)	DS	9-9-9-24	1.65	•		
G.SKILL	F3-15000CL9D-4GBRH (XMP)	4GB(2 x 2GB)	DS	9-9-9-24	1.65	•	•	
G.SKILL	F3-15000CL9D-4GBTD(XMP)	4GB(2 x 2GB)	DS	9-9-9-24	1.65	•	•	
KINGSTON	KHX1866C9D3T1K3/6GX(XMP)	6GB(3 x 2GB)	DS	9	1.65	•		
OCZ	OCZ3RPR1866C9LV3GK	3GB(3 x 1GB)	SS	9-9-9	1.65	•		
OCZ	OCZ3P1866LV4GK	4GB(2 x 2GB)	DS	9-9-9	1.65	•		
OCZ	OCZ3P1866C9LV6GK	6GB(3 x 2GB)	DS	9-9-9	1.65	•		
OCZ	OCZ3RPR1866C9LV6GK	6GB(3 x 2GB)	DS	9-9-9	1.65	•		
Super Talent	W1866UX2G8(XMP)	2GB(2 x 1GB)	SS	8-8-8-24	-	•		
Patriot	PVS32G1866LLK(XMP)	2GB(2 x 1GB)	SS	8-8-8-24	1.9	•		
Patriot	PVS32G1866LLK(XMP)	2GB(2 x 1GB)	SS	8-8-8-24	1.9	•		
Team	BoxP/N:TXD34096M1866HC7DC-L(TXD32048M1866HC7-L)(XMP)	4GB(2 x 2GB)	DS	7-7-7-21	1.65	•		

## P7F7-E WS Supercomputer Motherboard Qualified Vendors Lists (QVL) DDR3-1800MHz capability

Part No.	Size	SS/DS	Timing	Voltage	DIMM socket support (Optional)		
					2	4	6
KINGSTON	KHX1800C9D3T1K3/6GX(XMP)	6GB(3 x 2GB)	DS	-	1.65	•	•
OCZ	OCZ3P18002GK	2GB(2 x 1GB)	SS	8	-	•	
OCZ	OCZ3P18002GK	2GB(2 x 1GB)	SS	8	-	•	
Patriot	PVS32G1800LLKN(EPP)	2GB(2 x 1GB)	SS	8-8-8-20	1.9	•	

## P7F7-E WS Supercomputer Motherboard Qualified Vendors Lists (QVL) DDR3-1600MHz capability

Part No.	Size	SS/DS	Timing	Voltage	DIMM socket support (Optional)		
					2	4	6
A-DATA	AX3U1600GB2G9-AG(XMP)	4GB(2 x 2GB)	DS	9-9-9-24	1.65-1.85	•	•
A-DATA	AX3U1600XB2G7-EF(XMP)	4GB(2 x 2GB)	DS	7-7-7-20	1.75-1.85	•	
A-DATA	AD31600F002GMU(XMP)	6GB(3 x 2GB)	DS	7-7-7-20	1.75-1.85	•	
A-DATA	AX3U1600GB2G9-3G(XMP)	6GB(3 x 2GB)	DS	9-9-9-24	1.65-1.85	•	•
A-DATA	AX3U1600GB2G9-3G(XMP)	6GB(3 x 2GB)	DS	9-9-9-24	1.65-1.85	•	•
A-DATA	AX3U1600XB2G7-FF(XMP)	6GB(3 x 2GB)	DS	7-7-7-20	1.75-1.85	•	
CORSAIR	CMD4GX3M2A1600C8(XMP)	4GB(2 x 2GB)	DS	8-8-8-24	1.65	•	
CORSAIR	CMG4GX3M2A1600C7(XMP)	4GB(2 x 2GB)	DS	7-7-7-20	1.65	•	
CORSAIR	CMX4GX3M2A1600C9(XMP)	4GB(2 x 2GB)	DS	9-9-9-24	1.65	•	
CORSAIR	TR3X6G1600C8D	6GB(3 x 2GB)	DS	8-8-8-24	1.65	•	
CORSAIR	TR3X6G1600C9Ver2.1(XMP)	6GB(3 x 2GB)	DS	9-9-9-24	1.65	•	•
CORSAIR	CMD8GX3M4A1600C8(XMP)	8GB(4 x 2GB)	DS	8-8-8-24	1.65	•	•
CORSAIR	CMX8GX3M4A1600C9(XMP)	8GB(4 x 2GB)	DS	9-9-9-24	1.65	•	
Crucial	BL25664BN1608.16FF(XMP)	2GB	DS	8-8-8-24	1.65	•	•
G.SKILL	F3-12800CL7D-4GBECO(XMP)	4GB(2 x 2GB)	DS	7-8-7-24	-	•	•
G.SKILL	F3-12800CL7D-4GBRH(XMP)	4GB(2 x 2GB)	DS	7-7-7-24	1.65	•	
G.SKILL	F3-12800CL8D-4GBRM(XMP)	4GB(2 x 2GB)	DS	8-8-8-24	1.6	•	•
G.SKILL	F3-12800CL9D-4GBECO(XMP)	4GB(2 x 2GB)	DS	9-9-9-24	1.35	•	
G.SKILL	F3-12800CL8T-6GBP(XMP)	6GB(3 x 2GB)	DS	8-8-8-21	1.6-1.65	•	•
G.SKILL	F3-12800CL9T-6GBNQ	6GB(3 x 2GB)	DS	9-9-9-24	1.5-1.6	•	•
GEIL	GV34GB1600C8DC	4GB(2 x 2GB)	DS	8-8-8-28	1.6	•	•
KINGMAX	FLGE85F-B8MF7(XMP)	2GB	DS		-	•	•
KINGSTON	KHX1600C9D3K3/12GX(XMP)	12GB(3 x 4GB)	DS	-	1.65	•	•
KINGSTON	KHX1600C8D3K2/4GX(XMP)	4GB(2 x 2GB)	DS	8	1.65	•	•

KINGSTON	KHX1600C8D3K2/4GX(XMP)	4GB(2 x 2GB)	DS	8	1.65	•	•
KINGSTON	KHX1600C8D3T1K2/4GX(XMP)	4GB(2 x 2GB)	DS	8	1.65	•	•
KINGSTON	KHX1600C9D3K3/6GX(XMP)	6GB(3 x 2GB)	DS	9	1.65	•	•
OCZ	OCZ3OB1600LV4GK	4GB(2 x 2GB)	DS	9-9-9	1.65	•	
OCZ	OCZ3P1600EB4GK	4GB(2 x 2GB)	DS	7-7-6	1.8	•	
OCZ	OCZ3X16004GK(XMP)	4GB(2 x 2GB)	DS	7-7-7	1.9	•	•
OCZ	OCZ3G1600LV6GK	6GB(3 x 2GB)	DS	8-8-8	1.65	•	
OCZ	OCZ3X1600LV6GK(XMP)	6GB(3 x 2GB)	DS	8-8-8	1.65	•	•
OCZ	OCZ3X1600LV6GK(XMP)	6GB(3 x 2GB)	DS	8-8-8	1.65	•	
Super Talent	WP160UX4G8(XMP)	4GB(2 x 2GB)	DS	8	-	•	
Super Talent	WB160UX6G8(XMP)	6GB(3 x 2GB)	DS	-	-		•
Super Talent	WB160UX6G8(XMP)	6GB(3 x 2GB)	DS	8	-	•	•
Cell Shock	CS322271	2GB(2 x 1GB)	DS	7-7-7-14	1.7-1.9	•	
EK Memory	EKM324L28BP8-116(XMP)	4GB(2 x 2GB)	DS	9	-	•	
Elixir	M2Y2G64CB8HA9N-DG(XMP)	2GB	DS	-	-	•	
Mushkin	996657	4GB(2 x 2GB)	DS	7-7-7-20	-	•	
Mushkin	998659(XMP)	6GB(3 x 2GB)	DS	9-9-9-24	1.5-1.6	•	
PATRIOT	PGS34G1600LLKA	4GB(2 x 2GB)	DS	7-7-7-20	1.7	•	
Patriot	PVS34G1600LLK(XMP)	4GB(2 x 2GB)	DS	7-7-7-20	1.9	•	
Patriot	PVS34G1600LLKN	4GB(2 x 2GB)	DS	7-7-7-20	2.0	•	
Patriot	PVT36G1600ELK	6GB(3 x 2GB)	DS	9-9-9-24	1.65	•	•
Patriot	PVT36G1600LLK(XMP)	6GB(3 x 2GB)	DS	8-8-8-24	1.65	•	
Team	BoxP/N:TXD34096M1600HC6DC-L (TXD32048M1600HC6-L)(XMP)	4GB(2 x 2GB)	DS	6-7-6-18	1.65	•	•
A-DATA	AD31600G001GMU	1GB	SS	9-9-9-24	1.65-1.85	•	
A-DATA	AX3U1600PB1G8-2P	2GB(2 x 1GB)	SS	8-8-8-24	1.65-1.85	•	•
A-DATA	AD31600E001GMU	3GB(3 x 1GB)	SS	8-8-8-24	1.65-1.85	•	•
A-DATA	AX3U1600PB1G8-3P	3GB(3 x 1GB)	SS	8-8-8-24	1.65-1.85	•	•
CORSAIR	TR3X3G1600C8DVer2.1(XMP)	3GB(3 x 1GB)	SS	8-8-8-24	1.65	•	
Crucial	BL12864BA1608.8SFB(XMP)	1GB	SS	-	1.8	•	•
G.SKILL	F3-12800CL9D-2GBNQ	2GB(2 x 1GB)	SS	-	1.6	•	
G.SKILL	F3-12800CL9D-4GBRL	2GB(2 x 1GB)	SS	-	1.6	•	
OCZ	OCZ3P1600LV3GK	3GB(3 x 1GB)	SS	7-7-7	1.65	•	•

## P7F7-E WS Supercomputer Motherboard Qualified Vendors Lists (QVL) DDR3-1333MHz capability

Part No.	Size	SS/ DS	Chip Brand	Chip NO.	Timing	Voltage	DIMM socket support (Optional)		
							2	4	6
A-DATA	AD31333002GOU	2GB	DS	A-DATA	AD30908C8D-15IG	-	-	•	•
A-DATA	AD3U1333B2G9-2	2GB	DS	A-DATA	AD30908C8D-15IG	-	-	•	•
A-DATA	AX3U1333PB2G7-2P	4GB (2 x 2GB)	DS	-	-	7-7-7-20	1.65-1.85	•	•
A-DATA	AD3U1333C4G9-B	4GB	DS	Hynix	H5TQ2G83AFRH9C	1333-9-9- 9-24	-	•	•
A-DATA	AD31333E002G0U	6GB (3 x 2GB)	DS	-	-	7-7-7-20	1.65-1.85	•	•
A-DATA	AX3U1333PB2G7-3P	6GB (3 x 2GB)	DS	-	-	7-7-7-20	1.65-1.85	•	•
Apacer	78.A1GC6.9L1	2GB	DS	Apacer	AM5D5808DEWSBG	9	-	•	•
CORSAIR	CM3X1024-1333C9DHX	1GB	DS	-	-	-	1.1	•	
CORSAIR	Box P/N: TWIN3X2048-1333C9 (CM3X1024-1333C9) Ver1.1	2GB (2 x 1GB)	DS	-	-	9-9-9-24	1.70	•	
CORSAIR	CM3X2G1333C9	2GB	DS	-	-	9-9-9-24	1.5	•	•
CORSAIR	TR3X6G1333C9 (Ver.2.1)	6GB (3 x 2GB)	DS	-	-	9-9-9-24	1.5	•	
CORSAIR	CMX8GX3M4A1333C9	8GB (4 x 2GB)	DS	-	-	9-9-9-24	1.5	•	•
Crucial	BL25664BN1337.16FF(XMP)	2GB	DS	-	-	7-7-7-24	1.65	•	
Crucial	CT25664BA1339.16FF	2GB	DS	MICRON	D9KPT	9	-	•	•
Crucial	CT25664BA1339.16SFD	2GB	DS	MICRON	D9JNM	-	-	•	•
Crucial	CT25672BA1339.18FF	2GB	DS	MICRON	D9KPT(ECC)	9	-	•	•
Crucial	BL25664BA1336.16SFB1	4GB (2 x 2GB)	DS	NA	-	6-6-6-20	1.8	•	•
ELPIDA	EBJ21UE8BAW0-DJ-E	2GB	DS	ELPIDA	J1108BABG-DJ-E	9	-	•	
ELPIDA	EBJ21UE8BDF0-DJ-F	2GB	DS	ELPIDA	J1108BDSE-DJ-F	-	-	•	•
ELPIDA	EBJ21UE8EDF0-DJ-F	2GB	DS	ELPIDA	J1108EDSE-DJ-F	-	-	•	•
G.SKILL	F3-10666CL7T-6GBPK(XMP)	2GB	DS	-	-	7-7-7-18	1.5-1.6	•	•
G.SKILL	F3-10666CL7D-4GBPI(XMP)	4GB (2 x 2GB)	DS	-	-	7-7-7-21	1.5	•	•
G.SKILL	F3-10666CL7D-4GBRH(XMP)	4GB (2 x 2GB)	DS	-	-	7-7-7-21	1.5	•	•
G.SKILL	F3-10666CL8D- 4GBECO(XMP)	4GB (2 x 2GB)	DS	-	-	8-8-8-24	1.35	•	•
G.SKILL	F3-10666CL8D-4GBHK(XMP)	4GB (2 x 2GB)	DS	-	-	8-8-8-21	1.5-1.6	•	•
G.SKILL	F3-10666CL8D-4GBRM(XMP)	4GB (2 x 2GB)	DS	-	-	8-8-8-21	1.5-1.6	•	•
G.SKILL	F3-10666CL9T-6GBNQ	6GB (3 x 2GB)	DS	-	-	9-9-9-24	1.5	•	
GEIL	GG34GB1333C9DC	4GB (2 x 2GB)	DS	GEIL	GL1L128M88BA12N	9-9-9-24	1.3	•	•
GEIL	GV34GB1333C7DC	4GB (2 x 2GB)	DS	-	-	7-7-7-24	1.5	•	•

Hynix	HMT125U6BFR8C-H9	2GB	DS	Hynix	H5TQ1G83BFR	9	-	.	.
Hynix	HMT125U6BFR8C-H9	2GB	DS	Hynix	H5TQ1G83BFRH9C	9	-	.	.
KINGMAX	FLFE85F-B8KG9	2GB	DS	KingMax	KFB8FNGBF-ANX-15A	-	-	.	.
KINGSTON	KVR1333D3N9/2G	2GB	DS	Qimonda	IDSH1G-03A1F1C-13H	9	1.5	.	.
KINGSTON	KVR1333D3E9S/4G	4GB	DS	SAMSUNG	K4B2G0846B-HCH9	-	1.5	.	.
KINGSTON	KVR1333D3N9/4G	4GB	DS	SAMSUNG	K4B2G0846B-HCH9	9	1.5	.	.
MICRON	MT16JF25664AZ-1G4F1	2GB	DS	MICRON	D9KPT	9	-	.	.
MICRON	MT16JTF25664AZ-1G4F1	2GB	DS	MICRON	9FF22 D9KPT	9	-	.	.
MICRON	MT18JSF25672AZ-1G4F1	2GB	DS	MICRON	D9KPT(ECC)	9	-	.	.
OCZ	OCZ3P13332GK	1GB	DS	-	-	7-7-7-20	-	.	.
OCZ	OCZ3G1333LV4GK	4GB(2 x 2GB)	DS	-	-	8-8-8	1.65	.	.
OCZ	OCZ3P1333LV4GK	4GB(2 x 2GB)	DS	-	-	7-7-7	1.65	.	.
OCZ	OCZ3G1333LV6GK	6GB(3 x 2GB)	DS	-	-	9-9-9	1.65	.	.
OCZ	OCZ3P1333LV6GK	6GB(3 x 2GB)	DS	-	-	7-7-7	1.65	.	.
OCZ	OCZX1333LV6GK(XMP)	6GB(3 x 2GB)	DS	NA	-	8-8-8	1.6	.	.
PSC	AL8F8G73D-DG1	2GB	DS	PSC	A3P1GF3DGF	-	-	.	.
SAMSUNG	M378B5673DZ1-CH9	2GB	DS	SAMSUNG	K4B1G0846D	9	-	.	.
SAMSUNG	M378B5673EH1-CH9	2GB	DS	SAMSUNG	K4B1G0846E	-	-	.	.
SAMSUNG	M391B5673DZ1-CH9	2GB	DS	SAMSUNG	K4B1G0846D(ECC)	9	-	.	.
SAMSUNG	M378B5273BH1-CH9	4GB	DS	SAMSUNG	K4B2G0846B-HCH9	9	-	.	.
Asint	SLZ3128M8-EDJ	2GB	DS	Asint	DDRIII1208-DJ	-	-	.	.
Asint	SLZ3128M8-EDJE	2GB	DS	ELPIDA	J1108BASE-DJ-E	-	-	.	.
ASUS	N/A	1GB	DS	-	-	-	-	.	.
ATP	AQ56M64B8BJH9S	2GB	DS	SAMSUNG	K4B1G0846D	-	-	.	.
ATP	AQ56M72E8BJH9S	2GB	DS	SAMSUNG	K4B1G0846D(ECC)	-	-	.	.
BUFFALO	FSX1333D3G-2G	2GB	DS	-	-	-	-	.	.
EK Memory	EKM324L28BP8-113	4GB(2 x 2GB)	DS	-	-	9	-	.	.
Elixir	M2Y2G64CB8HC9N-CG	2GB	DS	-	-	-	-	.	.
Patriot	PVT36G1333ELK	6GB(3 x 2GB)	DS	-	-	9-9-9-24	1.65	.	.
Silicon Power	SP002GBLTU133S02	2GB	DS	S-POWER	I0YT3E0	9	-	.	.
UMAX	E41302GP0-73BDB	2GB	DS	UMAX	U2S24D30TP-13	-	-	.	.
A-DATA	AD3133301GOU	1GB	SS	A-DATA	AD30908C8D-15IG	-	-	.	.
CORSAIR	TR3X3G1333C9 (Ver2.1)	3GB(3 x 1GB)	SS	-	-	9-9-9-24	1.5	.	.

Crucial	CT12864BA1339.8FF	1GB	SS	MICRON	D9KPT	9	-	-	•	•	•
Crucial	CT12864BA1339.8SFD	1GB	SS	MICRON	MT8JF12864AY-1G4D1	-	-	-	•	•	
Crucial	CT12872BA1339.9FF	1GB	SS	MICRON	D9KPT(ECC)	9	-	-	•	•	
ELPIDA	EBJ10UE8BAW0-DJ-E	1GB	SS	ELPIDA	J1108BABG-DJ-E	9	-	-	•	•	•
ELPIDA	EBJ10UE8BDF0-DJ-F	1GB	SS	ELPIDA	J1108BDSE-DJ-F	-	-	-	•	•	
ELPIDA	EBJ10UE8EDF0-DJ-F	1GB	SS	ELPIDA	J1108EDSE-DJ-F	-	-	-	•	•	
G.SKILL	F3-10600CL7D-2GBPI	2GB(2 x 1GB)	SS	-	-	-	-	1.65	•		
G.SKILL	F3-10600CL8D-2GBHK	2GB(2 x 1GB)	SS	-	-	-	-	1.65	•	•	
Hynix	HMT112U6BFR8C-H9	1GB	SS	Hynix	H5TQ1G83BFR	9	-	-	•	•	•
KINGMAX	FLFD45F-B8KG9	1GB	SS	KingMax	KFB8FNGBF-ANX-15A	-	-	-	•		
KINGSTON	KVR1333D3N9/1G	1G	SS	Kingston	D128BJELD9U	-	-	1.5	•	•	
MICRON	MT8JTF12864AZ-1G4F1	1GB	SS	MICRON	9FF22 D9KPT	9	-	-	•	•	
MICRON	MT8JTF12864AZ-1G4F1	1GB	SS	MICRON	D9KPT	9	-	-	•	•	•
MICRON	MT9JSF12872AZ-1G4F1	1GB	SS	MICRON	D9KPT(ECC)	9	-	-	•	•	
OCZ	OCZ3RPX1333EB2GK	1GB	SS	-	-	-	-	-	•		
OCZ	OCZ3RPX1333EB2GK	2GB(2 x 1GB)	SS	NANYA	-	6-5-5	1.85	•			
OCZ	OCZ3G1333LV3GK	3GB(3 x 1GB)	SS	-	-	9-9-9	1.65	•			
OCZ	OCZ3P1333LV3GK	3GB(3 x 1GB)	SS	-	-	7-7-7	1.65	•	•		
PSC	AL7F8G73D-DG1	1GB	SS	PSC	A3P1GF3DGF	-	-	-	•	•	•
SAMSUNG	M378B2873DZ1-CH9	1GB	SS	SAMSUNG	K4B1G0846D	9	-	-	•	•	
SAMSUNG	M378B2873EH1-CH9	1GB	SS	SAMSUNG	K4B1G0846E	-	-	-	•	•	
SAMSUNG	M391B2873DZ1-CH9	1GB	SS	SAMSUNG	K4B1G0846D(ECC)	9	-	-	•	•	•
Super Talent	W1333UX2G8(XMP)	2GB(2 x 1GB)	SS	-	-	8	1.8	•	•	•	
Asint	SLY3128M8-EDJ	1GB	SS	Asint	DDRIII1208-DJ	-	-	-	•	•	
Asint	SLY3128M8-EDJE	1GB	SS	ELPIDA	J1108BASE-DJ-E	-	-	-	•	•	
ATP	AQ28M64A8BJH9S	1GB	SS	SAMSUNG	K4B1G0846E	-	-	-	•	•	
ATP	AQ28M72D8BJH9S	1GB	SS	SAMSUNG	K4B1G0846D(ECC)	-	-	-	•	•	•
BUFFALO	FSX1333D3G-1G	1GB	SS	-	-	-	-	-	•	•	
BUFFALO	FSH1333D3G-T3G(XMP)	3GB(3 x 1GB)	SS	-	-	7-7-20	-	-	•	•	•
Patriot	PDC32G1333LLK	1GB	SS	PATRIOT	-	7	1.7	•			
Silicon Power	SP001GBLTU1333S01	1GB	SS	NANYA	NT5CB128M8AN-CG	-	-	-	•	•	•
Silicon Power	SP001GBLTU1333S02	1GB	SS	S-POWER	I0YT3E0	9	-	-	•	•	

## P7F7-E WS Supercomputer Motherboard Qualified Vendors Lists (QVL) DDR3-1066MHz capability

Part No.	Size	SS/ DS	Chip Brand	Chip NO.	Timing	Voltage	DIMM socket support (Optional)		
							2	4	6
Crucial	CT25664BA1067.16FF	2GB	DS	MICRON	D9KPT	7	-	•	•
Crucial	CT25664BA1067.16SFD	2GB	DS	MICRON	D9JNL	7	-	•	•
Crucial	CT25672BA1067.18FF	2GB	DS	MICRON	D9KPT(ECC)	7	-	•	•
ELPIDA	EBJ11RD8BAFA-AE-E	1GB	DS	ELPIDA	J5308BASE-AC-E(ECC)	7	-	•	
ELPIDA	EBJ21UE8EDF0-AE-F	2GB	DS	ELPIDA	J1108EDSE-DJ-F	-	-	•	•
Hynix	HMT125U6AFP8C-G7N0	2GB	DS	HYNIX	H5TQ1G83AFP6G7C	7	-	•	•
Hynix	HYMT125U64ZNF8-G7	2GB	DS	HYNIX	HY5TQ1G831ZNF6G7	7	-	•	•
KINGSTON	KVR1066D3N7/2G	2GB	DS	KINGSTON	D1288JJEKAPGA7U	7	1.5	•	•
KINGSTON	KVR1066D3N7/2G	2GB	DS	ELPIDA	J1108BAGB-DJ-E	-	1.5	•	•
KINGSTON	KVR1066D3N7/4G	4GB	DS	SAMSUNG	K4B2G0846B-HCF8	-	1.5	•	•
MICRON	MT16JTF25664AY-1G1D1	2GB	DS	MICRON	7VD22	7	-	•	
MICRON	MT16JTF25664AZ-1G1F1	2GB	DS	MICRON	8ZF22 D9KPV	7	-	•	•
MICRON	MT16JTF25664AZ-1G1F1	2GB	DS	MICRON	D9KPT	7	-	•	•
MICRON	MT18JSF25672AZ-1G1F1	2GB	DS	MICRON	D9KPT(ECC)	7	-	•	•
SAMSUNG	M378B5273BH1-CF8	4GB	DS	SAMSUNG	K4B2G0846B-HCF8	8	1.5	•	•
Asint	SLZ3128M8-EAE	2GB	DS	Asint	DDRIII1208-AE	-	-	•	•
Elixir	M2Y2G64CB8HA9N-BE	2GB	DS	-	-	-	-	•	•
Elixir	M2Y2G64CB8HC5N-BE	2GB	DS	Elixir	N2CB1G80CN-BE	-	-	•	•
Elixir	M2Y2G64CB8HC9N-BE	2GB	DS	-	-	-	-	•	•
WINTEC	3DU3191A-10	1GB	DS	Qimonda	IDSH51-03A1F1C-10F	7	-	•	
Crucial	CT12864BA1067.8SFD	1GB	SS	MICRON	D9JNL	7	-	•	•
Crucial	CT12872BA1067.9FF	1GB	SS	MICRON	D9KPT(ECC)	7	-	•	•
ELPIDA	EBJ10UE8BAW0-AE-E	1GB	SS	ELPIDA	J1108BAGB-DJ-E	7	-	•	•
ELPIDA	EBJ10UE8EDF0-AE-F	1GB	SS	ELPIDA	J1108EDSE-DJ-F	-	-	•	•
Hynix	HMT112U6AFP8C-G7N0	1GB	SS	HYNIX	H5TQ1G83AFP6G7C	7	-	•	•
Hynix	HYMT112U64ZNF8-G7	1GB	SS	HYNIX	HY5TQ1G831ZNF6G7	7	-	•	
KINGSTON	KVR1066D3N7/1G	1GB	SS	KINGSTON	D1288JJEKAPA7U	7	1.5	•	•
MICRON	MT8JTF12864AY-1G1D1	1GB	SS	MICRON	7VD22	7	-	•	•
MICRON	MT8JTF12864AZ-1G1F1	1GB	SS	MICRON	8ZF22 D9KPV	7	-	•	•
MICRON	MT8JSF12872AZ-1G1F1	1GB	SS	MICRON	D9KPT(ECC)	7	-	•	•
Asint	SLY3128M8-EAE	1GB	SS	Asint	DDRIII1208-AE	-	-	•	
Crucial	CT12872BA1067.9FF	1GB	SS	MICRON	D9KPT(ECC)	7	-	•	•
ELPIDA	EBJ10UE8BAW0-AE-E	1GB	SS	ELPIDA	J1108BAGB-DJ-E	7	-	•	•
ELPIDA	EBJ10UE8EDF0-AE-F	1GB	SS	ELPIDA	J1108EDSE-DJ-F	-	-	•	•
Hynix	HMT112U6AFP8C-G7N0	1GB	SS	HYNIX	H5TQ1G83AFP6G7C	7	-	•	•



Hynix	HYMT112U64ZNF8-G7	1GB	SS	HYNIX	HY5TQ1G831ZNP-G7	7	-	•		
KINGSTON	KVR1066D3N7/1G	1GB	SS	KINGSTON	D1288JEKAPA7U	7	1.5	•	•	•
MICRON	MT8JTF12864AY-1G1D1	1GB	SS	MICRON	7VD22	7	-	•	•	•
MICRON	MT8JTF12864AZ-1G1F1	1GB	SS	MICRON	8ZF22 D9KPV	7	-	•	•	•
MICRON	MT8JTF12864AZ-1G1F1	1GB	SS	MICRON	D9KPT	7	-	•	•	•
MICRON	MT9JSF12872AZ-1G1F1	1GB	SS	MICRON	D9KPT(ECC)	7	-	•	•	•
Asint	SLY3128M8-EAE	1GB	SS	Asint	DDRIII1208-AE	-	-			•



### 6 DIMM Slots

- 2 DIMM: Supports two (2) modules inserted into slot A1 and B1 as one set of Dual-channel memory configuration
- 4 DIMM: Supports four (4) modules inserted into the blue slots (A1 and B1) and the black slot A2, A3 or B2, B3 as two sets of Dual-channel memory configuration.
- 6 DIMM: Supports six (6) modules inserted into both the blue slots and the black slots as two sets of Dual-channel memory configuration.

## Clarkdale CPU

### P7F7-E WS Supercomputer Motherboard Qualified Vendors Lists (QVL) DDR3-1600MHz capability

Part No.	Size	SS/DS	Timing	Voltage	DIMM socket support (Optional)			
					1	2	4	
A-DATA	AD31600G001GMU	1GB	SS	9-9-9-24	1.65-1.85	•	•	•
A-DATA	AX3U1600GB1G9-AG	2GB(2 x 1GB)	SS	9-9-9-24	1.65-1.85	•	•	•
A-DATA	AX3U1600GB1G9-3G	3GB(3 x 1GB)	SS	9-9-9-24	1.65-1.85	•	•	•
A-DATA	AX3U1600GB2G9-AG(XMP)	4GB(2 x 2GB)	DS	9-9-9-24	1.65-1.85	•	•	•
A-DATA	AX3U1600XB2G7-EF(XMP)	4GB(2 x 2GB)	DS	7-7-7-20	1.75-1.85	•	•	•
A-DATA	AD31600F002GMU(XMP)	6GB(3 x 2GB)	DS	7-7-7-20	1.75-1.85	•	•	•
A-DATA	AX3U1600GB2G9-3G(XMP)	6GB(3 x 2GB)	DS	9-9-9-24	1.65-1.85	•	•	•
A-DATA	AX3U1600GB2G9-3G(XMP)	6GB(3 x 2GB)	DS	9-9-9-24	1.65-1.85	•	•	•
A-DATA	AX3U1600GB2G9-3G	6GB(3 x 2GB)	DS	9-9-9-24	1.65-1.85	•	•	•
A-DATA	AX3U1600XB2G7-FF(XMP)	6GB(3 x 2GB)	DS	7-7-7-20	1.75-1.85	•	•	•
CORSAIR	TR3X3G1600C8DVer2.1(XMP)	3GB(3 x 1GB)	SS	8-8-8-24	1.65	•	•	
CORSAIR	CMG4GX3M2A1600C7(XMP)	4GB(2 x 2GB)	DS	7-7-7-20	1.65	•	•	•
CORSAIR	CMX4GX3M2A1600C9(XMP)	4GB(2 x 2GB)	DS	9-9-9-24	1.65	•	•	•
CORSAIR	TR3X6G1600C8DVer2.1(XMP)	6GB(3 x 2GB)	DS	8-8-8-24	1.65	•	•	
CORSAIR	TR3X6G1600C9Ver2.1(XMP)	6GB(3 x 2GB)	DS	9-9-9-24	1.65	•	•	•
CORSAIR	CMD8GX3M4A1600C8(XMP)	8GB(4 x 2GB)	DS	8-8-8-24	1.65	•	•	•
CORSAIR	CMX8GX3M4A1600C9(XMP)	8GB(4 x 2GB)	DS	9-9-9-24	1.65	•	•	•

Crucial	BL12864BA1608.8SFB(XMP)	1GB	SS	-	1.8	*	*	*
Crucial	BL25664BN1608.16FF(XMP)	2GB	DS	8-8-8-24	1.65	*	*	
G.SKILL	F3-12800CL9D-2GBNQ	2GB(2 x 1GB)	SS	-	1.6	*	*	*
G.SKILL	F3-12800CL9D-4GBRL	2GB(2 x 1GB)	SS	-	1.6	*	*	*
G.SKILL	F3-12800CL7D-4GBRH(XMP)	4GB(2 x 2GB)	DS	7-7-7-24	1.65	*		
G.SKILL	F3-12800CL8T-6GBPI(XMP)	6GB(3 x 2GB)	DS	8-8-8-21	1.6-1.65	*		*
G.SKILL	F3-12800CL9T-6GBNQ	6GB(3 x 2GB)	DS	9-9-9-24	1.5-1.6	*	*	*
GEIL	GV34GB1600C8DC	4GB(2 x 2GB)	DS	8-8-8-28	1.6	*	*	
KINGSTON	KHX1600C9D3K3/12GX(XMP)	12GB(3 x 4GB)	DS	-	1.65	*	*	
KINGSTON	KHX1600C8D3K2/4GX(XMP)	4GB(2 x 2GB)	DS	8	1.65	*	*	*
KINGSTON	KHX1600C8D3K2/4GX(XMP)	4GB(2 x 2GB)	DS	8	1.65	*	*	
KINGSTON	KHX1600C8D3T1K2/4GX(XMP)	4GB(2 x 2GB)	DS	8	1.65	*	*	*
KINGSTON	KHX1600C9D3K3/6GX(XMP)	6GB(3 x 2GB)	DS	9	1.65	*	*	*
OCZ	OCZ3G1600LV3GK	3GB(3 x 1GB)	SS	8-8-8	1.65	*	*	*
OCZ	OCZ3P1600LV3GK	3GB(3 x 1GB)	SS	7-7-7	1.65	*	*	*
OCZ	OCZ3P1600LV4GK	4GB(2 x 2GB)	DS	7-7-7	1.65	*		
OCZ	OCZ3X16004GK(XMP)	4GB(2 x 2GB)	DS	7-7-7	1.9	*	*	*
OCZ	OCZ3X1600LV4GK(XMP)	4GB(2 x 2GB)	DS	8-8-8	1.65	*	*	*
OCZ	OCZ3FXE1600C7LV6GK	6GB(3 x 2GB)	DS	7-7-7	1.65	*		
OCZ	OCZ3G1600LV6GK	6GB(3 x 2GB)	DS	8-8-8	1.65	*	*	*
OCZ	OCZ3X1600LV6GK(XMP)	6GB(3 x 2GB)	DS	8-8-8	1.65	*	*	*
OCZ	OCZ3X1600LV6GK(XMP)	6GB(3 x 2GB)	DS	8-8-8	1.65	*	*	*
Super Talent	WP160UX4G8(XMP)	4GB(2 x 2GB)	DS	8	-	*	*	
Super Talent	WP160UX4G9(XMP)	4GB(2 x 2GB)	DS	9	-	*	*	*
Super Talent	WB160UX6G8(XMP)	6GB(3 x 2GB)	DS	-	-	*		*
Super Talent	WB160UX6G8(XMP)	6GB(3 x 2GB)	DS	8	-	*	*	*
Cell Shock	CS322271	2GB(2 x 1GB)	DS	7-7-7-14	1.7-1.9	*	*	*
Elixir	M2Y2G64CB8HA9N-DG(XMP)	2GB	DS	-	-	*	*	*
Mushkin	996657	4GB(2 x 2GB)	DS	7-7-7-20	-	*	*	*
Mushkin	998659(XMP)	6GB(3 x 2GB)	DS	9-9-9-24	1.5-1.6	*	*	
Patriot	PVT33G1600ELK	3GB(3 x 1GB)	SS	9-9-9-24	1.65	*	*	*
PATRIOT	PGS34G1600LLKA	4GB(2 x 2GB)	DS	7-7-7-20	1.7	*	*	
Patriot	PVS34G1600ELK	4GB(2 x 2GB)	DS	9-9-9-24	1.8	*	*	
Patriot	PVS34G1600LLK(XMP)	4GB(2 x 2GB)	DS	7-7-7-20	1.9	*		
Patriot	PVS34G1600LLKN	4GB(2 x 2GB)	DS	7-7-7-20	2.0	*	*	
Patriot	PVT36G1600ELK	6GB(3 x 2GB)	DS	9-9-9-24	1.65	*	*	*
Patriot	PVT36G1600ELK	6GB(3 x 2GB)	DS	9-9-9-24	1.65	*	*	*
Patriot	PVT36G1600LLK(XMP)	6GB(3 x 2GB)	DS	8-8-8-24	1.65	*		

## P7F7-E WS Supercomputer Motherboard Qualified Vendors Lists (QVL) DDR3-1333MHz capability

Part No.	Size	SS/ DS	Chip Brand	Chip NO.	Timing	Voltage	DIMM socket support (Optional)			
							1	2	4	
A-DATA	AD3133301GOU	1GB	SS	A-DATA	AD30908C8D-15IG	-	-	•	•	•
A-DATA	AD31333002GOU	2GB	DS	A-DATA	AD30908C8D-15IG	-	-	•		
A-DATA	AD3U1333B2G9-2	2GB	DS	A-DATA	AD30908C8D-15IG	-	-	•		
A-DATA	AX3U1333PB2G7-2P	4GB(2 x 2GB)	DS	-	-	7-7-7-20	1.65-1.85	•	•	•
A-DATA	AD3U1333C4G9-B	4GB	DS	Hynix	H5TQ2G83AFRH9C	1333-9-9-9-24	-		•	•
A-DATA	AD31333E002GOU	6GB(3 x 2GB)	DS	-	-	7-7-7-20	1.65-1.85	•	•	•
A-DATA	AX3U1333PB2G7-3P	6GB(3 x 2GB)	DS	-	-	7-7-7-20	1.65-1.85	•	•	•
CORSAIR	TR3X3G1333C9 (Ver2.1)	3GB(3 x 1GB)	SS	-	-	9-9-9-24	1.5	•	•	•
CORSAIR	CM3X1024-1333C9DHX	1GB	DS	-	-	-	1.1	•	•	
CORSAIR	BoxP/N:TWIN3X2048-1333C9 (CM3X1024-1333C9)Ver1.1	2GB(2 x 1GB)	DS	-	-	9-9-9-24	1.70	•	•	•
CORSAIR	CM3X2G1333C9	2GB	DS	-	-	9-9-9-24	1.5	•	•	•
CORSAIR	TR3X6G1333C9 (Ver2.1)	6GB(3 x 2GB)	DS	-	-	9-9-9-24	1.5	•	•	
CORSAIR	CMX8GX3M4A1333C9	8GB(4 x 2GB)	DS	-	-	9-9-9-24	1.5	•	•	•
Crucial	CT12864BA1339.8FF	1GB	SS	MICRON	D9KPT	9	-	•	•	•
Crucial	CT12864BA1339.8SFD	1GB	SS	MICRON	MT&JF12864AY-1G4D1	-	-	•	•	•
Crucial	CT12872BA1339.9FF	1GB	SS	MICRON	D9KPT(ECC)	9	-	•	•	•
Crucial	BL25664BN1337.16FF(XMP)	2GB	DS	-	-	7-7-7-24	1.65	•	•	•
Crucial	CT25664BA1339.16FF	2GB	DS	MICRON	D9KPT	9	-	•	•	
Crucial	CT25664BA1339.16SFD	2GB	DS	MICRON	D9JNM	-	-	•	•	•
Crucial	CT25672BA1339.18FF	2GB	DS	MICRON	D9KPT(ECC)	9	-	•	•	•
Crucial	BL25664BA1336.16SFB1	4GB(2 x 2GB)	DS	NA	-	6-6-6-20	1.8	•	•	
ELPIDA	EBJ10UE8BAW0-DJ-E	1GB	SS	ELPIDA	J1108BABG-DJ-E	9	-	•	•	•
ELPIDA	EBJ10UE8BDF0-DJ-F	1GB	SS	ELPIDA	J1108BDSE-DJ-F	-	-	•	•	•
ELPIDA	EBJ10UE8EDF0-DJ-F	1GB	SS	ELPIDA	J1108EDSE-DJ-F	-	-	•	•	•
ELPIDA	EBJ21UE8BAW0-DJ-E	2GB	DS	ELPIDA	J1108BABG-DJ-E	9	-	•	•	•
ELPIDA	EBJ21UE8BDF0-DJ-F	2GB	DS	ELPIDA	J1108BDSE-DJ-F	-	-	•	•	•
ELPIDA	EBJ21UE8EDF0-DJ-F	2GB	DS	ELPIDA	J1108EDSE-DJ-F	-	-	•	•	•
G.SKILL	F3-10600CL7D-2GBPI	2GB(2 x 1GB)	SS	-	-	-	1.65	•	•	
G.SKILL	F3-10600CL8D-2GBHK	2GB(2 x 1GB)	SS	-	-	-	1.65	•	•	•
G.SKILL	F3-10666CL7T-6GBPK(XMP)	2GB	DS	-	-	7-7-7-18	1.5-1.6	•	•	•
G.SKILL	F3-10666CL7D-4GBPI(XMP)	4GB(2 x 2GB)	DS	-	-	7-7-7-21	1.5	•	•	•

G.SKILL	F3-10666CL7D-4GBRH(XMP)	4GB(2 x 2GB)	DS	-	-		7-7-7-21	1.5	*	*	*
G.SKILL	F3-10666CL8D-4GBHK(XMP)	4GB(2 x 2GB)	DS	-	-		8-8-8-21	1.5-1.6	*	*	*
GEIL	GG34GB1333C9DC	4GB(2 x 2GB)	DS	GEIL	GL1L128M88BA12N		9-9-9-24	1.3	*	*	*
Hynix	HMT112U6BFR8C-H9	1GB	SS	Hynix	H5TQ1G83BFR		9	-	*	*	*
Hynix	HMT125U6BFR8C-H9	2GB	DS	Hynix	H5TQ1G83BFR		9	-	*	*	*
Hynix	HMT125U6BFR8C-H9	2GB	DS	Hynix	H5TQ1G83BFRH9C		9	-	*	*	*
KINGSTON	KVR1333D3N9/2G	2GB	DS	Qimonda	IDS11G-03A1F1C-13H		9	1.5	*	*	*
KINGSTON	KVR1333D3N9/4G	4GB	DS	SAMSUNG	K4B2G0846B-HCH9		9	1.5	*	*	*
MICRON	MT8JTF12864AZ-1G4F1	1GB	SS	MICRON	9FF22 D9KPT		9	-	*	*	*
MICRON	MT16JTF25664AZ-1G4F1	2GB	DS	MICRON	9FF22 D9KPT		9	-	*	*	*
OCZ	OCZ3G1333LV3GK	3GB(3 x 1GB)	SS	-	-		9-9-9	1.65	*	*	
OCZ	OCZ3P1333LV3GK	3GB(3 x 1GB)	SS	-	-		7-7-7	1.65	*	*	*
OCZ	OCZ3P13332GK	1GB	DS	-	-		7-7-7-20	-	*		
OCZ	OCZ3G1333ULV4GK	4GB(2 x 2GB)	DS	-	-		8-8-8	1.65	*	*	
OCZ	OCZ3P13334GK	4GB(2 x 2GB)	DS	-	-		7	1.8	*		
OCZ	OCZ3G1333LV6GK	6GB(3 x 2GB)	DS	-	-		9-9-9	1.65	*	*	
OCZ	OCZX1333LV6GK(XMP)	6GB(3 x 2GB)	DS	NA	-		8-8-8	1.6	*	*	*
PSC	AL7F8G73D-DG1	1GB	SS	PSC	A3P1GF3DGF		-	-	*	*	*
PSC	AL8F8G73D-DG1	2GB	DS	PSC	A3P1GF3DGF		-	-	*	*	
SAMSUNG	M378B2873DZ1-CH9	1GB	SS	SAMSUNG	K4B1G0846D		9	-	*	*	*
SAMSUNG	M378B2873EH1-CH9	1GB	SS	SAMSUNG	K4B1G0846E		-	-	*	*	*
SAMSUNG	M391B2873DZ1-CH9	1GB	SS	SAMSUNG	K4B1G0846D(ECC)		9	-	*	*	*
SAMSUNG	M378B5673DZ1-CH9	2GB	DS	SAMSUNG	K4B1G0846D		9	-	*	*	*
SAMSUNG	M378B5673EH1-CH9	2GB	DS	SAMSUNG	K4B1G0846E		-	-	*	*	*
SAMSUNG	M391B5673DZ1-CH9	2GB	DS	SAMSUNG	K4B1G0846D(ECC)		9	-	*	*	*
SAMSUNG	M378B5273BH1-CH9	4GB	DS	SAMSUNG	K4B2G0846B-HCH9		9	-	*	*	*
Super Talent	W1333UX2GB(XMP)	2GB(2 x 1GB)	SS	-	-		8	1.8	*	*	*
Transcend	TS128MLK64V3U	1GB	SS	SAMSUNG	K4B1G0846D		9	-	*	*	*
Transcend	TS256MLK64V3U	2GB	DS	SAMSUNG	K4B1G0846D		9	-	*	*	*
Asint	SLY3128M8-EDJ	1GB	SS	Asint	DDRIII1208-DJ		-	-	*	*	*
Asint	SLY3128M8-EDJE	1GB	SS	ELPIDA	J1108BASE-DJ-E		-	-	*	*	*
Asint	SLZ3128M8-EDJ	2GB	DS	Asint	DDRIII1208-DJ		-	-	*	*	*
Asint	SLZ3128M8-EDJE	2GB	DS	ELPIDA	J1108BASE-DJ-E		-	-	*	*	*
ASUS	N/A	1GB	DS	-	-		-	-	*	*	
ATP	AQ28M64A8BJH9S	1GB	SS	SAMSUNG	K4B1G0846E		-	-	*	*	*

ATP	AQ28M72D8BJH9S	1GB	SS	SAMSUNG	K4B1G0846D(ECC)	-	-	•	•	•
ATP	AQ56M64B8BJH9S	2GB	DS	SAMSUNG	K4B1G0846D	-	-	•	•	•
ATP	AQ56M72E8BJH9S	2GB	DS	SAMSUNG	K4B1G0846D(ECC)	-	-	•	•	•
BUFFALO	FSH1333D3G-T3G(XMP)	3GB(3 x 1GB)	SS	-	-	7-7-7-20	-	•	•	•
Elixir	M2Y2G64CB8HA9N-CG	2GB	DS	-	-	-	-	•	•	•
Patriot	PDC32G1333LLK	1GB	SS	PATRIOT	-	7	1.7	•	•	•
Patriot	PVT33G1333ELK	3GB(3 x 1GB)	SS	-	-	9-9-9-24	1.65	•	•	•
Patriot	PVS34G1333ELK	4GB(2 x 2GB)	DS	-	-	9-9-9-24	1.5	•	•	•
Patriot	PVS34G1333LLK	4GB(2 x 2GB)	DS	-	-	7-7-7-20	1.7	•	•	•
Patriot	PVT36G1333ELK	6GB(3 x 2GB)	DS	-	-	9-9-9-24	1.65	•	•	□
Silicon Power	SP001GBLTU133S02	1GB	SS	S-POWER	I0YT3E0	9	-	•	•	•
Silicon Power	SP002GBLTU133S02	2GB	DS	S-POWER	I0YT3E0	9	-	•	•	•

## P7F7-E WS Supercomputer Motherboard Qualified Vendors Lists (QVL) DDR3-1067MHz capability

Part No.	Size	SS/DS	Chip Brand	Chip NO.	Timing	Voltage	DIMM socket support (Optional)			
							1	2	4	
Crucial	CT12864BA1067.8FF	1GB	SS	MICRON	D9KPT	7	-	•	•	•
Crucial	CT12864BA1067.8SFD	1GB	SS	MICRON	D9JNL	7	-	•	•	•
Crucial	CT12872BA1067.9FF	1GB	SS	MICRON	D9KPT(ECC)	7	-	•	•	•
Crucial	CT25664BA1067.16FF	2GB	DS	MICRON	D9KPT	7	-	•	•	•
Crucial	CT25664BA1067.16SFD	2GB	DS	MICRON	D9JNL	7	-	•	•	•
Crucial	CT25672BA1067.18FF	2GB	DS	MICRON	D9KPT(ECC)	7	-	•	•	•
ELPIDA	EBJ10UE8BAW0-AE-E	1GB	SS	ELPIDA	J1108BABG-DJ-E	7	-	•	•	•
ELPIDA	EBJ10UE8EDF0-AE-F	1GB	SS	ELPIDA	J1108EDSE-DJ-F	-	-	•	•	•
ELPIDA	EBJ11UD8BAFA-AG-E	1GB	DS	ELPIDA	J5308BASE-AC-E	8	-	•	•	•
ELPIDA	EBJ21UE8EDF0-AE-F	2GB	DS	ELPIDA	J1108EDSE-DJ-F	-	-	•	•	•
Hynix	HMT112U6AFP8C-G7N0	1GB	SS	HYNIX	H5TQ1G83AFP7C	7	-	•	•	•
Hynix	HYMT112U64ZNF8-G7	1GB	SS	HYNIX	HY5TQ1G831ZNFP-G7	7	-	•	•	•
Hynix	HMT125U6AFP8C-G7N0	2GB	DS	HYNIX	H5TQ1G83AFP7C	7	-	•	•	•
Hynix	HYMT125U64ZNF8-G7	2GB	DS	HYNIX	HY5TQ1G831ZNFP-G7	7	-	•	•	•
KINGSTON	KVR1066D3N7/1G	1GB	SS	KINGSTON	D1288JEKAPA7U	7	1.5	•	•	•
KINGSTON	KVR1066D3N7/2G	2GB	DS	KINGSTON	D1288JEKAPGA7U	7	1.5	•	•	•
KINGSTON	KVR1066D3N7/2G	2GB	DS	ELPIDA	J1108BABG-DJ-E	-	1.5	•	•	•

KINGSTON	KVR1066D3N7/4G	4GB	DS	SAMSUNG	K4B2G0846B-HCF8	-	1.5	•
MICRON	MT8JTF12864AY-1G1D1	1GB	SS	MICRON	7VD22	7	-	• •
MICRON	MT8JTF12864AZ-1G1F1	1GB	SS	MICRON	8ZF22 D9KPV	7	-	• • •
MICRON	MT16JTF25664AY-1G1D1	2GB	DS	MICRON	7VD22	7	-	• • • •
MICRON	MT16JTF25664AZ-1G1F1	2GB	DS	MICRON	8ZF22 D9KPV	7	-	• • • •
SAMSUNG	M378B5273BH1-CF8	4GB	DS	SAMSUNG	K4B2G0846B-HCF8	8	1.5	• • • •
Asint	SLY3128M8-EAE	1GB	SS	Asint	DDRIII1208-AE	-	-	• • • •
Asint	SLZ3128M8-EAE	2GB	DS	Asint	DDRIII1208-AE	-	-	• • • •
Elixir	M2Y2G64CB8HA9N-BE	2GB	DS	-	-	-	-	• • • •
Elixir	M2Y2G64CB8HC5N-BE	2GB	DS	Elixir	N2CB1G80CN-BE	-	-	• • • •
Elixir	M2Y2G64CB8HC9N-BE	2GB	DS	-	-	-	-	• • • •
WINTEC	3DU3191A-10	1GB	DS	Qimonda	IDSH51-03A1F1C-10F	7	-	• • • •



---

#### 4 DIMM Slots

- 1 DIMM: Supports one module inserted into slot A1 or B1 as single channel memory configuration.
  - 2 DIMMs: Supports two (2) modules inserted into slot A1 and B1 as one set of Dual-channel memory configuration.
  - 4 DIMMs: Supports four (4) modules inserted into the blue slots (A1 and B1) and the black slot A2, A3 or B2, B3 as two sets of Dual-channel memory configuration.
-

### 2.4.3 Installing a DIMM



Ensure to unplug the power supply before adding or removing DIMMs or other system components. Failure to do so may cause severe damage to both the motherboard and the components.

1. Unlock a DIMM socket by pressing the retaining clip outward.
2. Align a DIMM on the socket such that the notch on the DIMM matches the DIMM slot key on the socket.

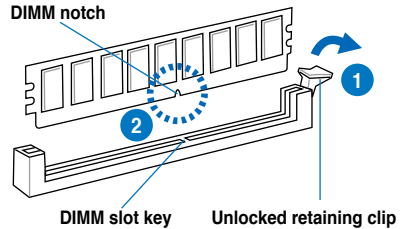

A DIMM is keyed with a notch so that it fits in only one direction. **DO NOT** force a DIMM into a socket in the wrong direction to avoid damaging the DIMM.

3. Hold the DIMM by both of its ends, then insert the DIMM vertically into the socket. Apply force to both ends of the DIMM simultaneously until the retaining clip snaps back into place, and the DIMM cannot be pushed in any further to ensure proper sitting of the DIMM.

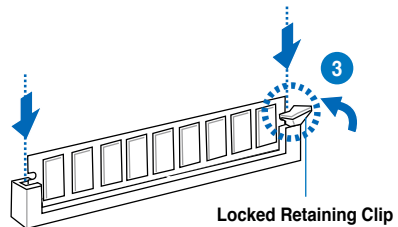

Always insert the DIMM into the socket **VERTICALLY** to prevent DIMM notch damage.

### 2.4.4 Removing a DIMM

1. Press the retaining clip outward to unlock the DIMM.
2. Remove the DIMM from the socket.

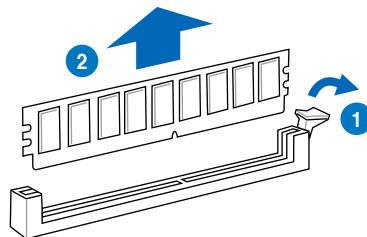

## 2.5 Expansion slots

In the future, you may need to install expansion cards. The following sub-sections describe the slots and the expansion cards that they support.



---

Ensure to unplug the power cord before adding or removing expansion cards. Failure to do so may cause you physical injury and damage motherboard components.

---

### 2.5.1 Installing an expansion card

To install an expansion card:

1. Before installing the expansion card, read the documentation that came with it and make the necessary hardware settings for the card.
2. Remove the system unit cover (if your motherboard is already installed in a chassis).
3. Remove the bracket opposite the slot that you intend to use. Keep the screw for later use.
4. Align the card connector with the slot and press firmly until the card is completely seated on the slot.
5. Secure the card to the chassis with the screw you removed earlier.
6. Replace the system cover.

### 2.5.2 Configuring an expansion card

After installing the expansion card, configure it by adjusting the software settings.

1. Turn on the system and change the necessary BIOS settings, if any. See Chapter 3 for information on BIOS setup.
2. Assign an IRQ to the card. Refer to the tables on the next page.
3. Install the software drivers for the expansion card.



---

When using PCI cards on shared slots, ensure that the drivers support “Share IRQ” or that the cards do not need IRQ assignments. Otherwise, conflicts will arise between the two PCI groups, making the system unstable and the card inoperable. Refer to the table on the next page for details.

---



## 2.5.3 Interrupt assignments

### Standard interrupt assignments

IRQ	Priority	Standard function
0	1	System Timer
1	2	Keyboard Controller
2	–	Redirect to IRQ#9
4	12	Communications Port (COM1)*
5	13	IRQ Holder for PCI Steering*
6	14	Reserved
7	15	Reserved
8	3	System CMOS/Real Time Clock
9	4	IRQ Holder for PCI Steering*
10	5	IRQ Holder for PCI Steering*
11	6	IRQ Holder for PCI Steering*
12	7	Reserved
13	8	Numeric Data Processor
14	9	Primary IDE Channel

\* These IRQs are usually available for PCI devices.

### IRQ assignments for this motherboard

	A	B	C	D	E	F	G	H
PCIEX16_1	shared	–	–	–	–	–	–	–
PCIEX16_2	–	shared	–	–	–	–	–	–
PCIEX16_3	–	–	shared	–	–	–	–	–
PCIEX16_4	–	–	–	shared	–	–	–	–
PCIEX1_1	–	–	–	shared	–	–	–	–
PCIEX1_2	–	–	shared	–	–	–	–	–
PCIEX1_3	shared	–	–	–	–	–	–	–
LAN1 (8112L)	–	–	–	shared	–	–	–	–
LAN2 (8112L)	–	shared	–	–	–	–	–	–
SATA 3G controller 1	–	–	–	–	–	shared	–	–
SATA 3G controller 2	–	–	–	–	–	shared	–	–
SATA 6G controller 1	–	–	shared	–	–	–	–	–
USB 2.0 controller 1	shared	–	–	–	–	–	–	–
USB 2.0 controller 2	–	–	–	–	–	–	–	shared
USB 3.0 controller 1	–	–	shared	–	–	–	–	–
1394 controller	–	–	shared	–	–	–	–	–
HD Audio	–	–	–	–	–	–	shared	–

## 2.5.4 PCI Express x1 slot

This motherboard supports PCI Express x1 network cards, SCSI cards and other cards that comply with the PCI Express specifications.



Install a PCIe x1 device to a PCIe x1 slot prior to a PCIe x16 slot.

## 2.5.5 PCI Express 2.0 x16 slots

This motherboard has four PCI Express 2.0 slots, two x8 link and two x8 or x16 link. These slots support VGA cards and various server class high performance add-on cards.

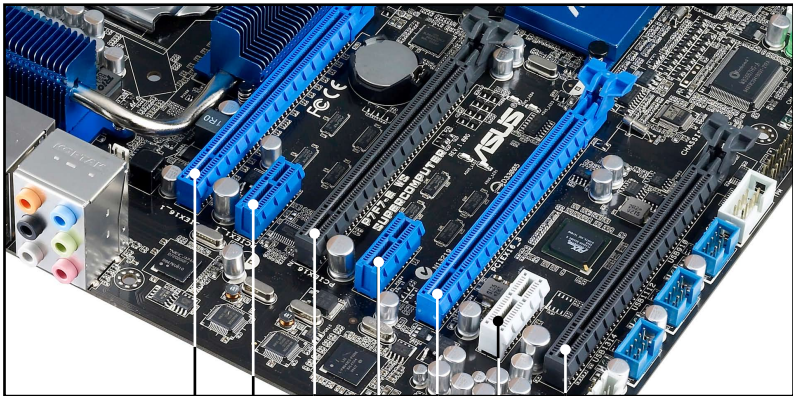

PCI Express 2.0 x16\_4 slot (x8 link)  
PCI Express x1\_3 slot  
PCI Express 2.0 x16\_3 slot (x8 or x16 link)  
PCI Express x1\_2 slot  
PCI Express 2.0 x16\_2 slot (x8 link)  
PCI Express x1\_1 slot  
PCI Express 2.0 x16\_1 slot (x8 or x16 link)



- When PCIe 2.0 x16\_2 and PCIe 2.0 x16\_4 slots are occupied, PCIe 2.0 x16\_1 and PCIe 2.0 x16\_3 will work at x8 link.
- In single VGA card mode, use first the PCIe 2.0 x16\_1 slot for a PCI Express x16 graphics card to get better performance.
- We recommend you use the PCIe 2.0 x16\_1, PCIe 2.0 x16\_2, and PCIe 2.0 x16\_3 slots for 3-way SLI, and the three slots will work at x8, x8 and x16 link respectively; the PCIe 2.0 x16\_1, PCIe 2.0 x16\_3 slots for two-way SLI, and both slots will work at x16 link.
- When using NVIDIA® CUDA™ Technology with a Quadro™ series graphics card and Tesla™ series computing processor cards, install the Quadro™ graphics card to PCIe 2.0 x16\_1 slot and the Tesla™ computing processor cards to PCIe 2.0 x16\_2, PCIe 2.0 x16\_3 and PCIe 2.0 x16\_4 slots.
- Connect a chassis fan to the motherboard connector labeled CHA\_FAN1/2/3 when using multiple graphics cards for better thermal environment. See page 2-42 for details.

## 2.6 Jumper

### Clear RTC RAM (3-pin CLRRTC)

This jumper allows you to clear the Real Time Clock (RTC) RAM in CMOS. You can clear the CMOS memory of date, time, and system setup parameters by erasing the CMOS RTC RAM data. The onboard button cell battery powers the RAM data in CMOS, which include system setup information such as system passwords.

To erase the RTC RAM

1. Turn OFF the computer and unplug the power cord.
2. Move the jumper cap from pins 1-2 (default) to pins 2-3. Keep the cap on pins 2-3 for about 5–10 seconds, then move the cap back to pins 1-2.
3. Plug the power cord and turn ON the computer.
4. Hold down the <Del> key during the boot process and enter BIOS setup to re-enter data.

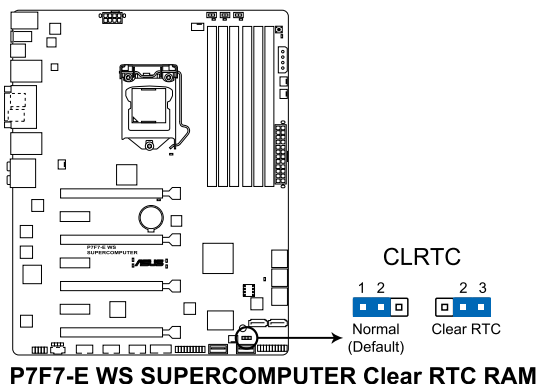

Except when clearing the RTC RAM, never remove the cap on CLRRTC jumper default position. Removing the cap will cause system boot failure!



- If the steps above do not help, remove the onboard battery and move the jumper again to clear the CMOS RTC RAM data. After the CMOS clearance, reinstall the battery.
- You do not need to clear the RTC when the system hangs due to overclocking. For system failure due to overclocking, use the C.P.R. (CPU Parameter Recall) feature. Shut down and reboot the system so the BIOS can automatically reset parameter settings to default values.
- Due to the chipset behavior, AC power off is required to enable C.P.R. function. You must turn off and on the power supply or unplug and plug the power cord before rebooting the system.

## 2.7 Connectors

### 2.7.1 Rear panel connectors

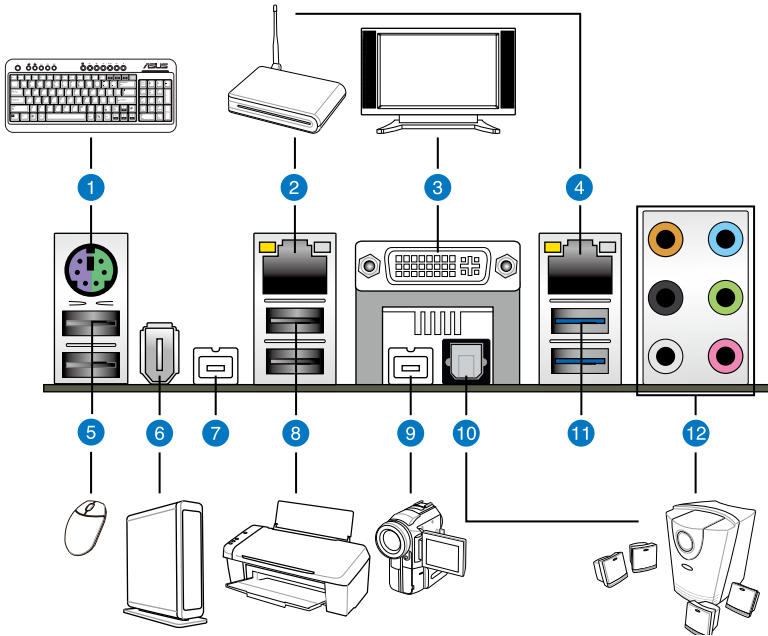

#### Rear panel connectors

1. PS/2 mouse/keyboard port (green/purple)	7. IEEE 1394b port
2. LAN (RJ-45) port*	8. USB 2.0 ports 3 and 4
3. DVI port	9. IEEE 1394b port
4. LAN (RJ-45) port*	10. Optical SPDIF_Out port
5. USB 2.0 ports 5 and 6	11. USB 3.0 ports 1 and 2
6. IEEE 1394a port	12. Audio I/O ports**

#### \* LAN port LED indications

Activity/Link	Speed LED	Description
OFF	OFF	Soft-off Mode
Yellow Blinking	OFF	During Power ON/OFF
Yellow Blinking	ORANGE	100 Mbps connection
Yellow Blinking	GREEN	1 Gbps connection

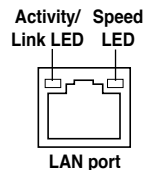

**\*\* Audio 2, 4, 6, 8, or 10-channel configuration**

Port	Headset 2-channel	4-channel	6-channel	8-channel	10-channel
Light Blue	Line In	Line In	Line In	Line In	Additional Side Speaker Out
Lime	Line Out	Front Speaker Out	Front Speaker Out	Front Speaker Out	Front Speaker Out
Pink	Mic In	Mic In	Mic In	Mic In	Mic In
Orange	–	–	Center/ Subwoofer	Center/ Subwoofer	Center/ Subwoofer
Black	–	Rear Speaker Out	Rear Speaker Out	Rear Speaker Out	Rear Speaker Out
Gray	–	–	–	Side Speaker Out	Side Speaker Out



Only Windows Vista or later version operating system supports 10-channel audio configuration.

**2.7.2 Audio I/O connections**

**Audio I/O ports**

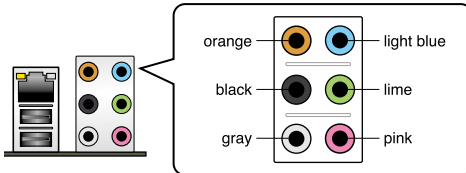

**Connect to Headphone and Mic**

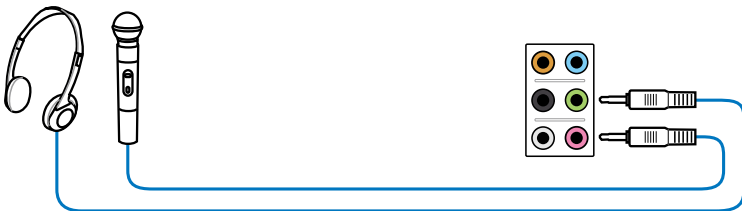

### Connect to Stereo Speakers

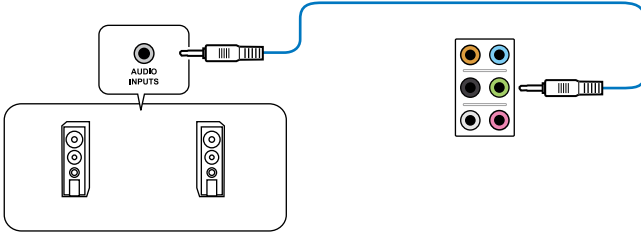

### Connect to 2.1 channel Speakers

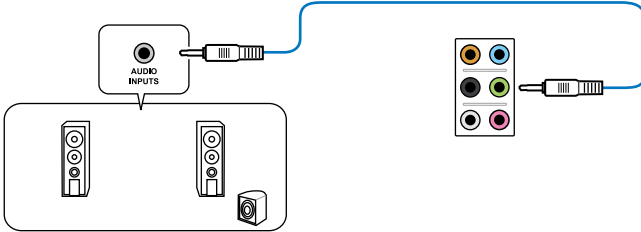

### Connect to 4.1 channel Speakers

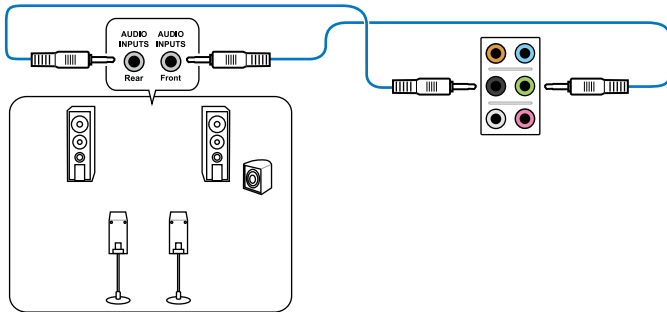

## Connect to 5.1 channel Speakers

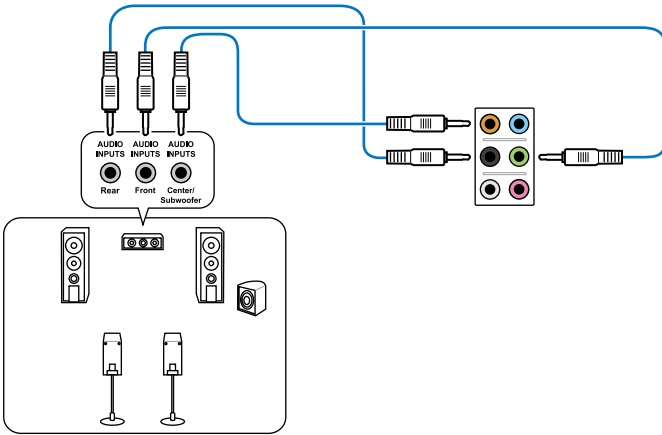

## Connect to 7.1 channel Speakers

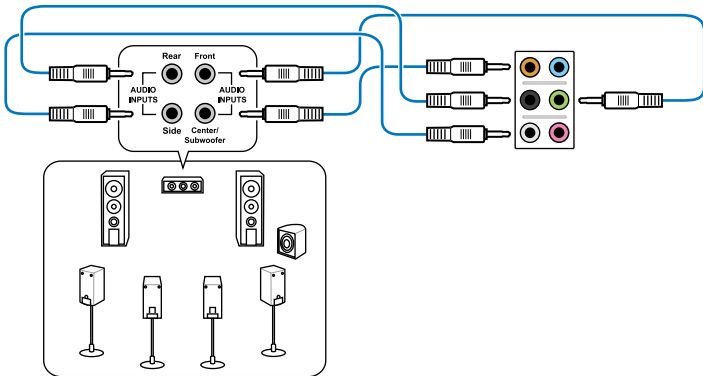

# Connect to 9.1-channel Speakers

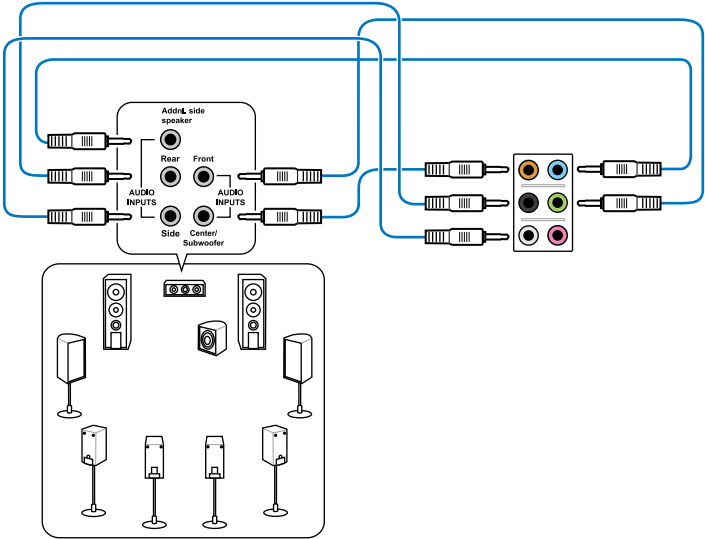



## 2.7.3 Internal connectors

### 1. Serial ATA 3.0 Gb/s connectors (7-pin SATA 1-6 [blue])

These connectors are for the Serial ATA signal cables for Serial ATA hard disk drives and optical disc drives.

If you installed Serial ATA hard disk drives, you can create a RAID 0, 1, 5, and 10 configuration with the Intel® Matrix Storage Technology through the onboard Intel® 3450 Ibx Peak.

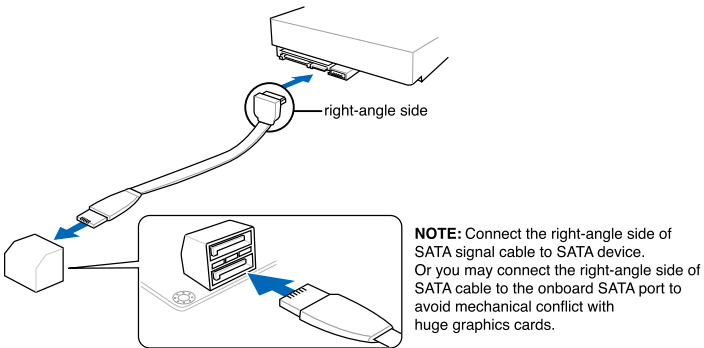
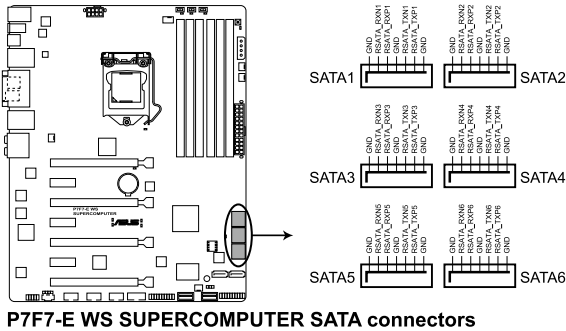

- These connectors are set to Standard IDE mode by default. In Standard IDE mode, you can connect Serial ATA boot/data hard disk drives to these connectors. If you intend to create a Serial ATA RAID set using these connectors, set the **Configure SATA as** item in the BIOS to [RAID]. See section **3.3.5 Storage Configuration** for details. Before creating a RAID set, refer to section **4.5 RAID Configuration**.
- You must install Windows® XP Service Pack 2 or later version before using Serial ATA hard disk drives. The Serial ATA RAID feature is available only if you are using Windows® XP SP2 or later version.
- When using hot-plug and NCQ, set the **Configure SATA as** in the BIOS to [AHCI]. See section **3.3.5 Storage Configuration** for details.

**2. Marvell® Serial ATA 6.0 Gb/s connectors (7-pin SATA\_6G\_1/2 [white])**

These connectors connect to Serial ATA 6.0 Gb/s hard disk drives via Serial ATA 6.0 Gb/s signal cables.

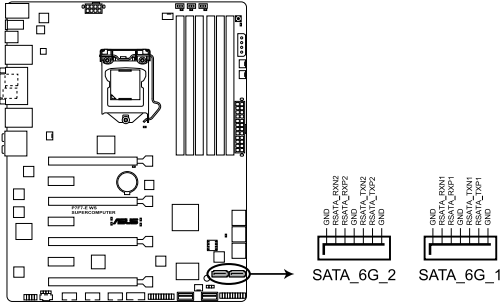

**P7F7-E WS SUPERCOMPUTER SATA\_6G connectors**



- These connectors are set to Standard IDE mode by default. In Standard IDE mode, you can connect Serial ATA data hard disk drives to these connectors.
- You must install Windows® XP Service Pack 2 or later versions before using Serial ATA hard disk drives.
- When using hot-plug and NCQ, set the **Marvell Controller** item in the BIOS to [AHCI Mode]. Refer to section **3.5.3 Onboard Devices Configuration** for details.

### 3. USB connectors and ports (10-1 pin USB910, USB1112, USB1314; A-Type USB7, USB8)

These connectors are for USB 2.0 ports. Connect the USB module cables to connectors USB 910, USB 1112, and USB1314, then install the modules to a slot opening at the back of the system chassis. These USB connectors comply with USB 2.0 specification that supports up to 480 Mbps connection speed.

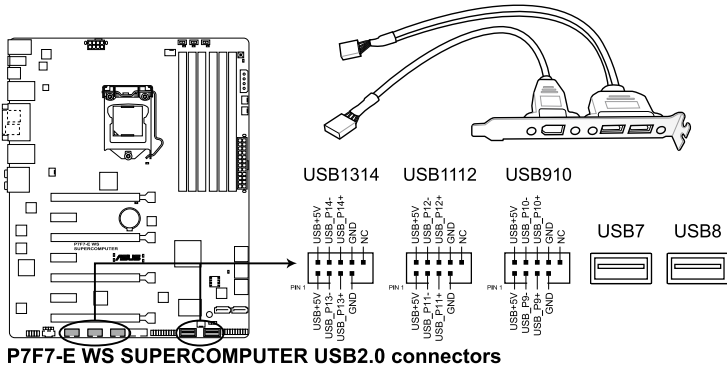

Never connect a 1394 cable to the USB connectors. Doing so will damage the motherboard!



You can connect the USB cable to ASUS Q-Connector (USB, blue) first, and then install the Q-Connector (USB) to the USB connector onboard.



The USB cable is purchased separately.

**4. Serial port connector (10-1 pin COM1)**

This connector is for a serial (COM) port. Connect the serial port module cable to this connector, then install the module to a slot opening at the back of the system chassis.

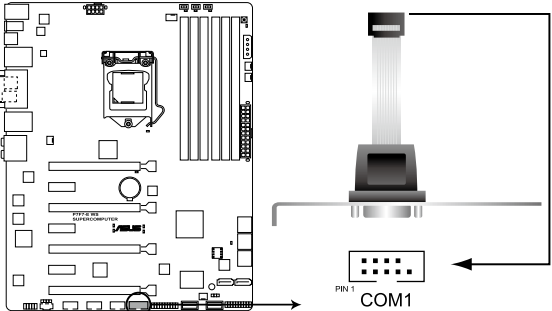

**P7F7-E WS SUPERCOMPUTER Serial port (COM1) connector**



---

The COM module is purchased separately.

---

**5. Digital audio connector (4-1 pin SPDIF\_OUT)**

This connector is for an additional Sony/Philips Digital Interface (S/PDIF) port(s). Connect the S/PDIF Out module cable to this connector, then install the module to a slot opening at the back of the system chassis.

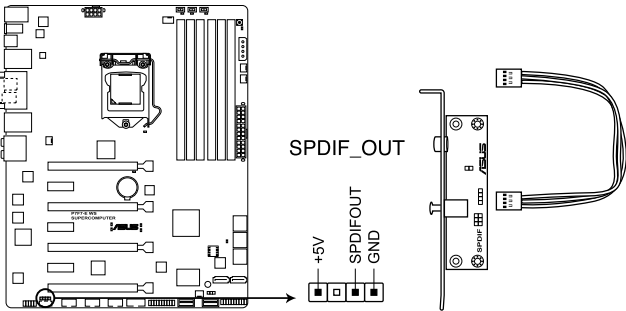

**P7F7-E WS SUPERCOMPUTER Digital audio connector**



---

The S/PDIF module is purchased separately.

---

## 6. Optical drive audio connector (4-pin CD)

These connectors allow you to receive stereo audio input from sound sources such as a CD-ROM, TV tuner, or MPEG card.

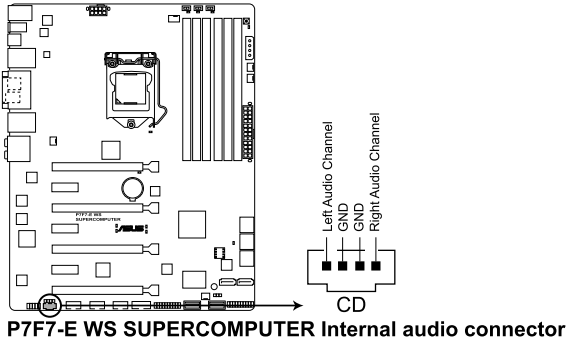

## 7. Front panel audio connector (10-1 pin AAFP)

This connector is for a chassis-mounted front panel audio I/O module that supports either HD Audio or legacy AC'97 audio standard. Connect one end of the front panel audio I/O module cable to this connector.

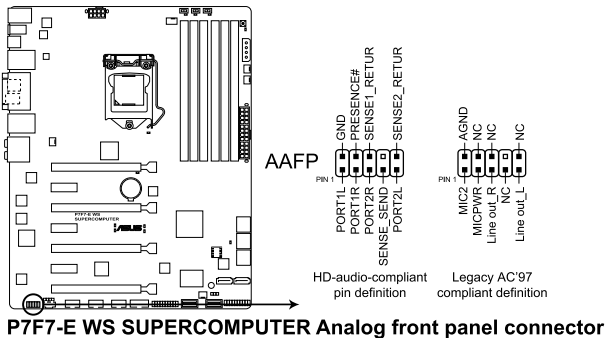

- We recommend that you connect a high-definition front panel audio module to this connector to avail of the motherboard's high-definition audio capability.
- If you want to connect a high-definition front panel audio module to this connector, set the **Front Panel Type** item in the BIOS setup to [HD Audio]; if you want to connect an AC'97 front panel audio module to this connector, set the item to [AC97]. By default, this connector is set to [HD Audio].

**8. CPU, chassis, and power fan connectors (4-pin CPU\_FAN, 3-pin CHA\_FAN1–3, 3-pin PWR\_FAN)**

The fan connectors support cooling fans of 350 mA–2000 mA (24 W max.) or a total of 1 A–7 A (84 W max.) at +12V. Connect the fan cables to the fan connectors on the motherboard, ensuring that the black wire of each cable matches the ground pin of the connector.



DO NOT forget to connect the fan cables to the fan connectors. Insufficient air flow inside the system may damage the motherboard components. These are not jumpers! DO NOT place jumper caps on the fan connectors!

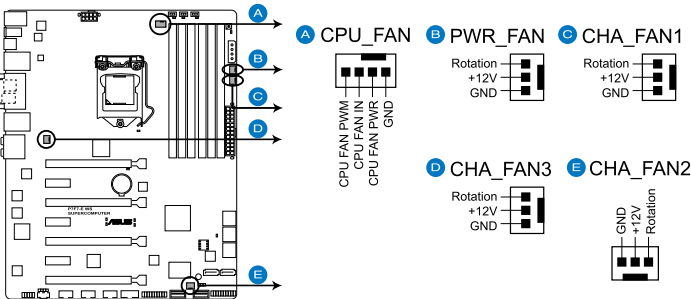

**P7F7-E WS SUPERCOMPUTER Fan connectors**

**9. TPM connector (20-1 pin TPM)**

This connector supports a Trusted Platform Module (TPM) system, which can securely store keys, digital certificates, passwords, and data. A TPM system also helps enhance network security, protects digital identities, and ensures platform integrity.

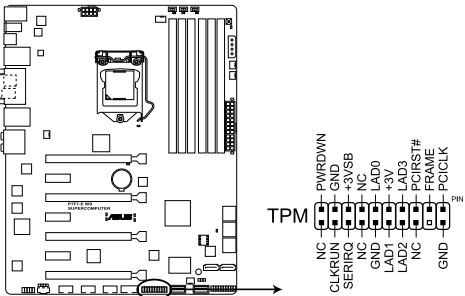

**P7F7-E WS SUPERCOMPUTER TPM connector**



The TPM module is purchased separately. Use the ASUS TPM module ONLY!

## 10. Power connectors

### (24-pin EATXPWR, 8-pin EATX12V, 4-pin EZ\_PLUG)

These connectors are for ATX power supply plugs. The power supply plugs are designed to fit these connectors in only one orientation. Find the proper orientation and push down firmly until the connectors completely fit.

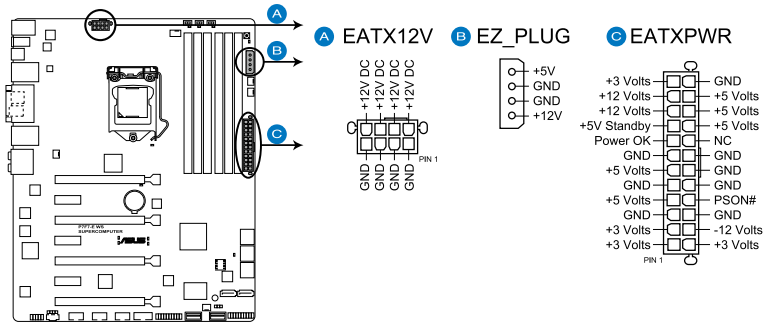

**P7F7-E WS SUPERCOMPUTER power connectors**



- Ensure to remove the cap on the EATX12V connector before connecting an 8-pin EPS +12V power plug.
- Use only an 8-pin EPS +12V power plug for the EATX12V connector.
- For a fully configured system, we recommend that you use a power supply unit (PSU) that complies with ATX 12 V Specification 2.0 (or later version) and provides a minimum power of 600 W.
- Do not forget to connect the 8-pin EATX12 V power plug; otherwise, the system will not boot.
- Remember to connect the EZ\_PLUG for a stabler +12V output when installing graphic cards that requires more than 18A on the +12V rail; otherwise, EATX12V connector might be overheated.
- Use of a PSU with a higher power output is recommended when configuring a system with more power-consuming devices. The system may become unstable or may not boot up if the power is inadequate.
- If you are uncertain about the minimum power supply requirement for your system, refer to the Recommended Power Supply Wattage Calculator at <http://support.asus.com/PowerSupplyCalculator/PSCalculator.aspx?SLanguage=en-us> for details.

## 11. System panel connector (20-8 pin PANEL)

This connector supports several chassis-mounted functions.

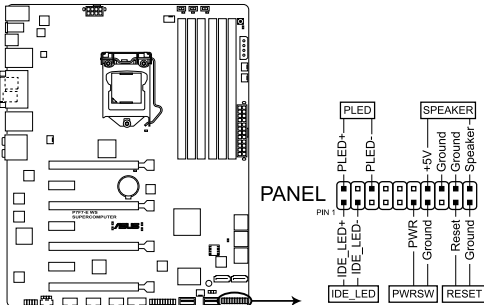

**P7F7-E WS SUPERCOMPUTER System panel connector**

- **System power LED (2-pin PLED)**

This 2-pin connector is for the system power LED. Connect the chassis power LED cable to this connector. The system power LED lights up when you turn on the system power, and blinks when the system is in sleep mode.

- **Hard disk drive activity LED (2-pin IDE\_LED)**

This 2-pin connector is for the HDD Activity LED. Connect the HDD Activity LED cable to this connector. The IDE LED lights up or flashes when data is read from or written to the HDD.

- **System warning speaker (4-pin SPEAKER)**

This 4-pin connector is for the chassis-mounted system warning speaker. The speaker allows you to hear system beeps and warnings.

- **ATX power button/soft-off button (2-pin PWRSW)**

This connector is for the system power button. Pressing the power button turns the system on or puts the system in sleep or soft-off mode depending on the BIOS settings. Pressing the power switch for more than four seconds while the system is ON turns the system OFF.

- **Reset button (2-pin RESET)**

This 2-pin connector is for the chassis-mounted reset button for system reboot without turning off the system power.



## 12. ASUS Q-Connector (system panel)

Use the ASUS Q-Connector to connect/disconnect the chassis front panel cables.

To install the ASUS Q-Connector:

1. Connect the front panel cables to the ASUS Q-Connector.

Refer to the labels on the Q-Connector to know the detailed pin definitions, and then match them to their respective front panel cable labels.



The labels on the front panel cables may vary depending on the chassis model.

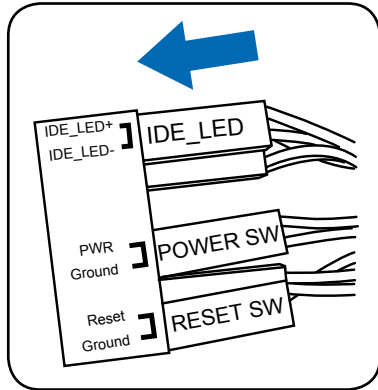

2. Install the ASUS Q-Connector to the system panel connector, ensuring the orientation matches the labels on the motherboard.

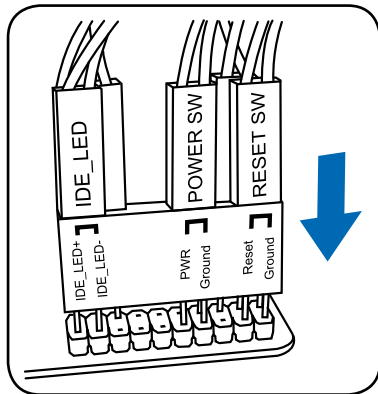

3. The front panel functions are now enabled. The figure shows the Q-Connector is properly installed on the motherboard.

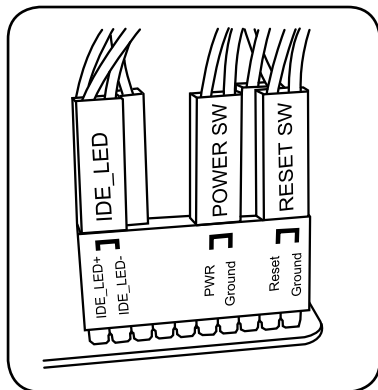

## 2.7.4 Onboard switches

Onboard switches allow you to fine-tune performance when working on a bare or open-case system. This is ideal for overclockers who continually change settings to enhance system performance.

### 1. MemOK! switch

Installing DIMMs that are incompatible with the motherboard may cause system boot failure, and the DIAG\_DRAM LED near the MemOK! switch lights continuously. Press and hold the MemOK! switch until the DIAG\_DRAM LED starts blinking to begin automatic memory compatibility tuning for successful boot.

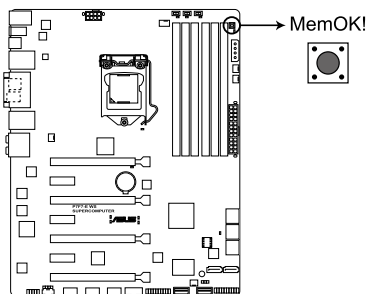

P7F7-E WS SUPERCOMPUTER MemOK! switch



- Refer to section **2.8 Onboard LEDs** for the exact location of the DIAG\_DRAM LED.
- The DIAG\_DRAM also lights when the DIMM is not properly installed. Turn off the system and reinstall the DIMM before using the MemOK! function.
- The MemOK! switch does not function under Windows™ OS environment.
- During the tuning process, the system loads and tests failsafe memory settings. It takes about 30 seconds for the system to test one set of failsafe settings. If the test fails, the system reboots and test the next set of failsafe settings. The blinking speed of the DIAG\_DRAM LED increases, indicating different test processes.
- Due to memory tuning requirement, the system automatically reboots when each timing set is tested. If the installed DIMMs still fail to boot after the whole tuning process, the DIAG\_DRAM LED lights continuously. Replace the DIMMs with ones recommended in the Memory QVL (Qualified Vendors Lists) in this user manual or on the ASUS website at [www.asus.com](http://www.asus.com).
- If you turn off the computer and replace DIMMs during the tuning process, the system continues memory tuning after turning on the computer. To stop memory tuning, turn off the computer and unplug the power cord for about 5–10 seconds.
- If your system fail to boot due to BIOS overclocking, press the MemOK! switch to boot and load BIOS default settings. A message will appear during POST reminding you that the BIOS has been restored to its default settings.
- We recommend that you download and update to the latest BIOS version from the ASUS website at [www.asus.com](http://www.asus.com) after using the MemOK! function.

## 2. CPU / IMC / DRAM overvoltage setting switches (OV\_DRAM, OV\_IMC, OV\_CPU)

These switches allow you to enable or disable the advanced CPU, Integrated Memory Controller (IMC), and DRAM overvoltage settings in BIOS. Read the following information before you change the switch settings.

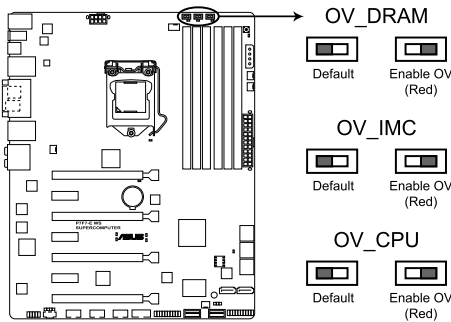

**P7F7-E WS SUPERCOMPUTER DRAM/ IMC/ CPU overvoltage setting**



The LED color indicates the voltage setting status of CPU, IMC and DRAM.

	OV_CPU	OV_IMC	OV_DRAM
Default	0.85V to 1.7V	up to 1.7V	up to 2.0V
Enable OV (red)	1.25V to 2.1V	up to 1.9V	up to 2.5V



- Before you change the switch settings for extra-high overvoltage ability, use the BIOS items first to adjust the desired CPU, IMC, and DRAM performance. Ensure your system functions well under the highest BIOS voltage settings before you change the setting of these three switches.
- DO NOT enable the OV\_CPU switch when you install a new CPU and have not booted for the first time. Doing so may cause the system to halt. For system failure due to the wrong setting of the OV\_CPU switch, shut down the computer and set the switch back to its default position.
- According to Intel CPU spec, DIMMs voltage below 1.65V is recommended to protect the CPU.
- The system may need a better cooling system (for example, a water-cooling system) to work stably under high voltage settings.

## 2.8 Onboard LEDs

### 1. POST State LEDs

POST State LEDs check key components (CPU, DRAM, VGA card, and HDD) in sequence during motherboard booting process. If an error is found, the LED next to the error device will continue lighting until the problem is solved. This user-friendly design provides an intuitive way to locate the root problem within seconds.

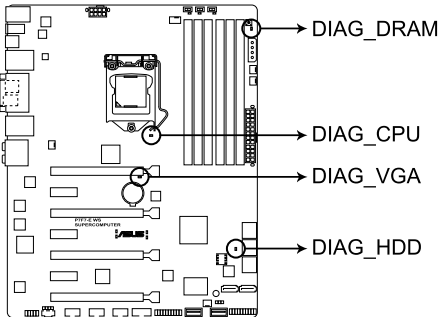

**P7F7-E WS SUPERCOMPUTER DIAG\_DRAM/ CPU/ VGA/ HDD LED**



You may disable the POST State LEDs in BIOS. Refer to section **3.7.3 Boot Setting Configuration** for details.

### 2. Standby power LED

The motherboard comes with a standby power LED that lights up to indicate that the system is ON, in sleep mode, or in soft-off mode. This is a reminder that you should shut down the system and unplug the power cable before removing or plugging in any motherboard component. The illustration below shows the location of the onboard LED.

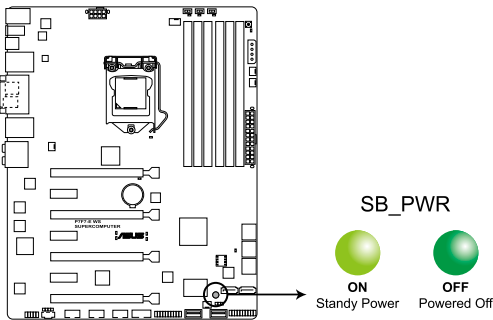

**P7F7-E WS SUPERCOMPUTER Onboard LED**

## 2.9 Starting up for the first time

1. After making all the connections, replace the system case cover.
2. Be sure that all switches are off.
3. Connect the power cord to the power connector at the back of the system chassis.
4. Connect the power cord to a power outlet that is equipped with a surge protector.
5. Turn on the devices in the following order:
  - a. Monitor
  - b. External SCSI devices (starting with the last device on the chain)
  - c. System power
6. After applying power, the system power LED on the system front panel case lights up. For systems with ATX power supplies, the system LED lights up when you press the ATX power button. If your monitor complies with “green” standards or if it has a “power standby” feature, the monitor LED may light up or switch between orange and green after the system LED turns on.

The system then runs the power-on self tests or POST. While the tests are running, the BIOS beeps (see BIOS beep codes table below) or additional messages appear on the screen. If you do not see anything within 30 seconds from the time you turned on the power, the system may have failed a power-on test. Check the jumper settings and connections or call your retailer for assistance.

BIOS Beep	Description
One short beep	VGA detected Quick boot set to disabled No keyboard detected
One continuous beep followed by two short beeps then a pause (repeated)	No memory detected
One continuous beep followed by three short beeps	No VGA detected
One continuous beep followed by four short beeps	Hardware component failure

7. At power on, hold down the <Delete> key to enter the BIOS Setup. Follow the instructions in Chapter 3.

## 2.10 Turning off the computer

### 2.10.1 Using the OS shut down function

If you are using Windows® Vista™ and Windows® 7:

1. Click the **Start** button then select **Shut Down**.
2. The power supply should turn off after Windows® shuts down.

If you are using Windows® XP:

1. Click the **Start** button then select **Turn Off Computer**.
2. Click the **Turn Off** button to shut down the computer.
3. The power supply should turn off after Windows® shuts down.

### 2.10.2 Using the dual function power switch

While the system is ON, pressing the power switch for less than four seconds puts the system to sleep mode or to soft-off mode, depending on the BIOS setting.

Pressing the power switch for more than four seconds lets the system enter the soft-off mode regardless of the BIOS setting. Refer to section **3.6 Power Menu** in Chapter 3 for details.

This chapter tells how to change the system settings through the BIOS Setup menus. Detailed descriptions of the BIOS parameters are also provided.

# BIOS setup **3**

3.1	Managing and updating your BIOS .....	3-1
3.2	BIOS setup program .....	3-7
3.3	Main menu .....	3-10
3.4	<b>Ai Tweaker menu</b> .....	3-15
3.5	Advanced menu .....	3-22
3.6	Power menu .....	3-29
3.7	Boot menu .....	3-34
3.8	Tools menu .....	3-38
3.9	Exit menu .....	3-42



## 3.1 Managing and updating your BIOS

The following utilities allow you to manage and update the motherboard Basic Input/Output System (BIOS) setup.

1. **ASUS Update** (Updates the BIOS in Windows® environment.)
2. **ASUS EZ Flash 2** (Updates the BIOS using a USB flash disk.)
3. **BUPDATER** (Updates the BIOS using a USB flash disk.)
4. **ASUS CrashFree BIOS 3 utility**: Restores the BIOS using the motherboard support DVD or a USB flash drive when the BIOS file fails or gets corrupted.

Refer to the corresponding sections for details on these utilities.



---

Save a copy of the original motherboard BIOS file to a USB flash drive in case you need to restore the BIOS in the future. Copy the original motherboard BIOS using the **ASUS Update** utility.

---

### 3.1.1 ASUS Update utility

The ASUS Update is a utility that allows you to manage, save, and update the motherboard BIOS in Windows® environment. The ASUS Update utility allows you to:

- Save the current BIOS file
- Download the latest BIOS file from the Internet
- Update the BIOS from an updated BIOS file
- Update the BIOS directly from the Internet, and
- View the BIOS version information.

This utility is available in the support DVD that comes with the motherboard package.



---

ASUS Update requires an Internet connection either through a network or an Internet Service Provider (ISP).

---

### Installing ASUS Update

To install ASUS Update:

1. Place the support DVD in the optical drive. The Drivers menu appears.
2. Click the Utilities tab, then click Install ASUS Update VX.XX.XX.
3. The ASUS Update utility is copied to your system.



Quit all Windows® applications before you update the BIOS using this utility.

## Updating the BIOS through the Internet

To update the BIOS through the Internet:

1. Launch the ASUS Update utility from the Windows® desktop by clicking **Start > Programs > ASUS > ASUSUpdate > ASUSUpdate**. The ASUS Update main window appears.

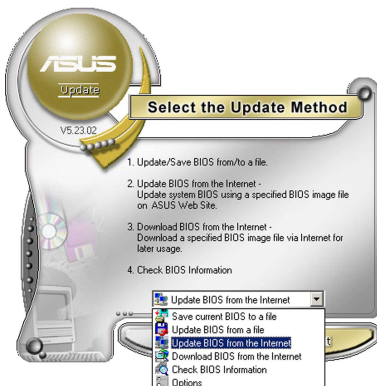
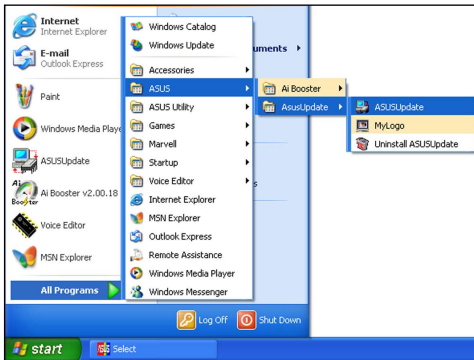

2. Select **Update BIOS** from the Internet option from the drop-down menu, then click **Next**.



3. Select the ASUS FTP site nearest you to avoid network traffic, or click **Auto Select**. Click **Next**.

- From the FTP site, select the BIOS version that you wish to download. Click **Next**.
- Follow the screen instructions to complete the update process.



The ASUS Update utility is capable of updating itself through the Internet. Always update the utility to avail all its features.

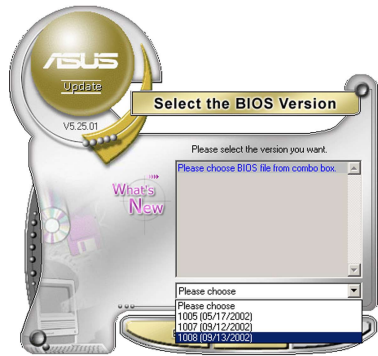

## Updating the BIOS through a BIOS file

To update the BIOS through a BIOS file:

- Launch the ASUS Update utility from the Windows® desktop by clicking **Start** > **Programs** > **ASUS** > **ASUSUpdate** > **ASUSUpdate**. The ASUS Update main window appears.
- Select **Update BIOS** from a file option from the drop-down menu, then click **Next**.

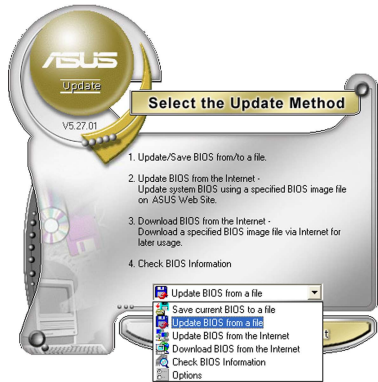

- Locate the BIOS file from the Open window, then click **Open**.
- Follow the screen instructions to complete the update process.

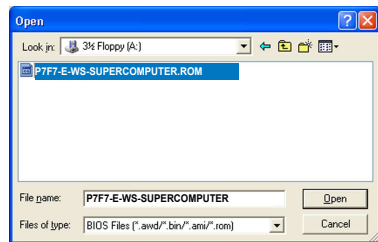

### 3.1.2 ASUS EZ Flash 2 utility

The ASUS EZ Flash 2 feature allows you to update the BIOS without having to use a DOS-based utility. The EZ Flash 2 utility is built in the BIOS chip so it is accessible by pressing <Alt> + <F2> during the Power-On Self Tests (POST).



Before you start using this utility, download the latest BIOS from the ASUS website at [www.asus.com](http://www.asus.com).

To update the BIOS using EZ Flash 2

1. Insert the USB flash disk that contains the latest BIOS file to the USB port, and then launch EZ Flash 2 in any of these two ways:
  - Press <Alt> + <F2> during POST to display the following.
  - Enter the BIOS setup program. Go to the **Tools** menu to select **EZ Flash 2** and press <Enter> to enable it.

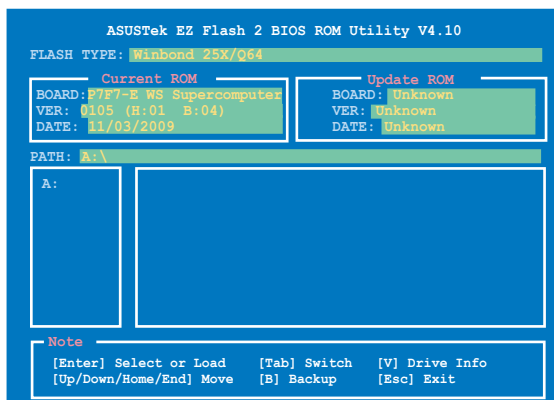

2. Press <Tab> to switch between drives until the correct BIOS file is found. When found, EZ Flash 2 performs the BIOS update process and automatically reboots the system when done.



- This function can support devices such as a USB flash disk with FAT 32/16 format and single partition only.
- DO NOT shut down or reset the system while updating the BIOS to prevent system boot failure!



Ensure to load the BIOS default settings to ensure system compatibility and stability. Select the **Load Setup Defaults** item under the **Exit** menu. See section **3.9 Exit Menu** for details.

### 3.1.3 BUPDATER utility



The succeeding BIOS screens are for reference only. The actual BIOS screen displays may not be the same as shown.

The BUPDATER utility allows you to update the BIOS file in DOS environment using a bootable USB flash disk drive with the updated BIOS file.

#### Updating the BIOS file

To update the BIOS file using the BUPDATER utility:

1. Visit the ASUS website at [www.asus.com](http://www.asus.com) and download the latest BIOS file for the motherboard. Save the BIOS file to a bootable USB flash disk drive.
2. Copy the BUPDATER utility (BUPDATER.exe) from the ASUS support website at [support.asus.com](http://support.asus.com) to the bootable USB flash disk drive.
3. Boot the system in DOS mode, then at the prompt, type:

```
BUPDATER /i [filename] .ROM
```

where [filename] is the latest or the original BIOS file on the bootable USB flash disk drive, then press <Enter>.

```
A:\>BUPDATER /i [file name] .ROM
```

The utility verifies the file, then starts updating the BIOS file.

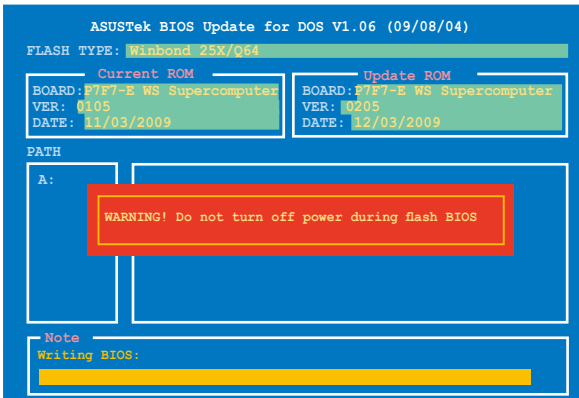

**DO NOT** shut down or reset the system while updating the BIOS to prevent system boot failure!

5. The utility returns to the DOS prompt after the BIOS update process is completed. Reboot the system from the hard disk drive.

```
The BIOS update is finished! Please restart your system.  
C:\>
```

### 3.1.4 ASUS CrashFree BIOS 3 utility

The ASUS CrashFree BIOS 3 utility is an auto recovery tool that allows you to restore the BIOS file when it fails or gets corrupted during the updating process. You can restore a corrupted BIOS file using the motherboard support DVD or a USB flash drive that contains the BIOS file.



---

The BIOS file in the motherboard support DVD may be older than the BIOS file published on the ASUS official website. If you want to use the newer BIOS file, download the file at [support.asus.com](http://support.asus.com) and save it to a USB flash drive.

---

## Recovering the BIOS

To recover the BIOS

1. Turn on the system.
2. Insert the motherboard support DVD to the optical drive, or the USB flash drive containing the BIOS file to the USB port.
3. The utility automatically checks the devices for the BIOS file. When found, the utility reads the BIOS file and starts flashing the corrupted BIOS file.
4. Turn off the system after the utility completes the updating process and power on again.
5. The system requires you to enter BIOS Setup to recover BIOS setting. To ensure system compatibility and stability, we recommend that you press <F2> to load default BIOS values.



---

**DO NOT** shut down or reset the system while recovering the BIOS! Doing so can cause system boot failure!

---

## 3.2 BIOS setup program

This motherboard supports two programmable firmware chips that you can update using the provided utility described in section **3.1 Managing and updating your BIOS**.

Use the BIOS Setup program when you are installing a motherboard, reconfiguring your system, or prompted to “Run Setup.” This section explains how to configure your system using this utility.

Even if you are not prompted to use the Setup program, you can change the configuration of your computer in the future. For example, you can enable the security password feature or change the power management settings. This requires you to reconfigure your system using the BIOS Setup program so that the computer can recognize these changes and record them in the CMOS RAM of the firmware chip.

The firmware chip on the motherboard stores the Setup utility. When you start up the computer, the system provides you with the opportunity to run this program. Press <Del> during the Power-On Self-Test (POST) to enter the Setup utility; otherwise, POST continues with its test routines.

If you wish to enter Setup after POST, restart the system by pressing <Ctrl+Alt+Delete>, or by pressing the reset button on the system chassis. You can also restart by turning the system off and then back on. Do this last option only if the first two failed.

The Setup program is designed to make it as easy to use as possible. Being a menu-driven program, it lets you scroll through the various sub-menus and make your selections from the available options using the navigation keys.



- 
- The default BIOS settings for this motherboard apply for most conditions to ensure optimum performance. If the system becomes unstable after changing any BIOS settings, load the default settings to ensure system compatibility and stability. Select the **Load Setup Defaults** item under the Exit Menu. See section **3.9 Exit Menu**.
  - The BIOS setup screens shown in this section are for reference purposes only, and may not exactly match what you see on your screen.
  - Visit the ASUS website at [www.asus.com](http://www.asus.com) to download the latest BIOS file for this motherboard.
-

### 3.2.1 BIOS menu screen

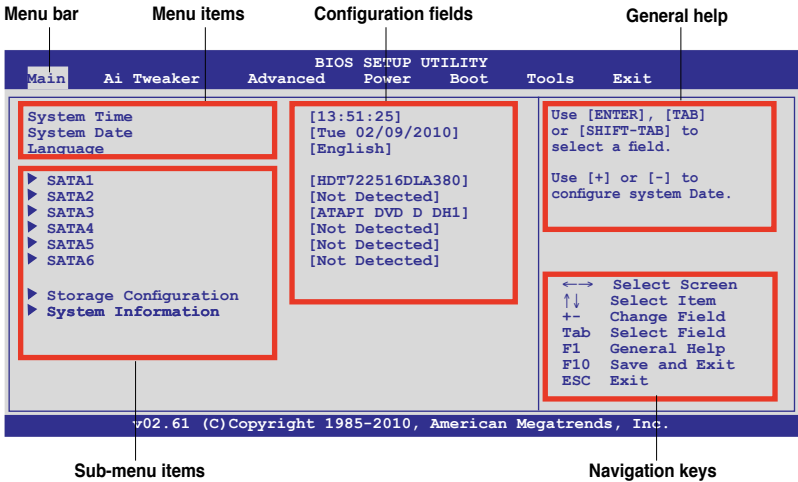

### 3.3.2 Menu bar

The menu bar on top of the screen has the following main items:

<b>Main</b>	For changing the basic system configuration
<b>Ai Tweaker</b>	For changing the overclocking settings
<b>Advanced</b>	For changing the advanced system settings
<b>Power</b>	For changing the advanced power management (APM) configuration
<b>Boot</b>	For changing the system boot configuration
<b>Tools</b>	For configuring options for special functions
<b>Exit</b>	For selecting the exit options and loading default settings

### 3.2.3 Navigation keys

At the bottom right corner of a menu screen are the navigation keys for that particular menu. Use the navigation keys to select items in the menu and change the settings.



Some of the navigation keys differ from one screen to another.



### 3.2.4 Menu items

The highlighted item on the menu bar displays the specific items for that menu. For example, selecting Main shows the Main menu items.

The other items (Advanced, Power, Boot, and Exit) on the menu bar have their respective menu items.

### 3.2.5 Submenu items

A solid triangle before each item on any menu screen means that the item has a submenu. To display the submenu, select the item and press <Enter>.

### 3.2.6 Configuration fields

These fields show the values for the menu items. If an item is user-configurable, you can change the value of the field opposite the item. You cannot select an item that is not user-configurable.

A configurable field is enclosed in brackets, and is highlighted when selected. To change the value of a field, select it then press <Enter> to display a list of options. Refer to **3.2.7 Pop-up window**.

### 3.2.7 Pop-up window

Select a menu item then press <Enter> to display a pop-up window with the configuration options for that item.

### 3.2.8 Scroll bar

A scroll bar appears on the right side of a menu screen when there are items that do not fit on the screen. Press the Up/Down arrow keys or <Page Up> / <Page Down> keys to display the other items on the screen.

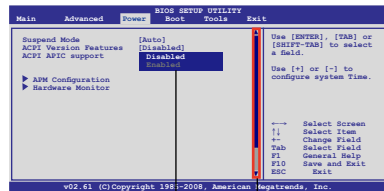

Scroll bar  
Pop-up window

### 3.2.9 General help

At the top right corner of the menu screen is a brief description of the selected item.

### 3.3 Main menu

When you enter the BIOS Setup program, the Main menu screen appears, giving you an overview of the basic system information.



Refer to section 3.2.1 **BIOS menu screen** for information on the menu screen items and how to navigate through them.



The default values of the following items vary depending on the CPU and memory modules you install on the motherboard.

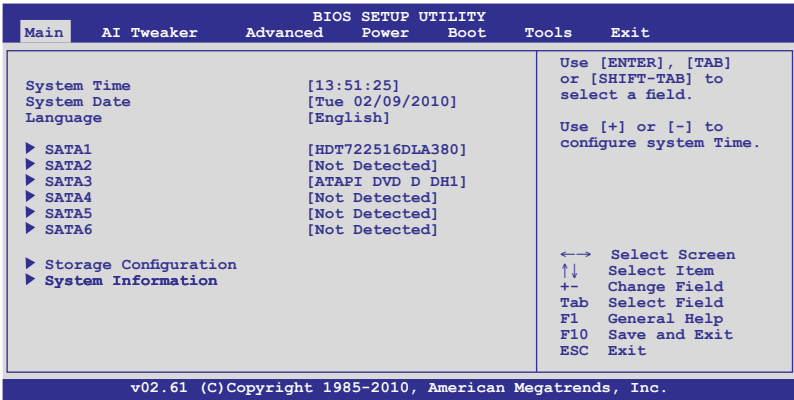

#### 3.3.1 System Time [xx:xx:xx]

Allows you to set the system time.

#### 3.3.2 System Date [Day xx/xx/xxxx]

Allows you to set the system date.

#### 3.3.3 Language [English]

Allows you to choose the BIOS language version from the options.

Configuration options: [繁體中文] [簡體中文] [日本語] [Français] [Deutsch] [English]

### 3.3.4 SATA 1-6

While entering Setup, the BIOS automatically detects the presence of IDE/SATA devices. There is a separate submenu for each IDE/SATA device. Select a device item then press <Enter> to display the SATA device information.

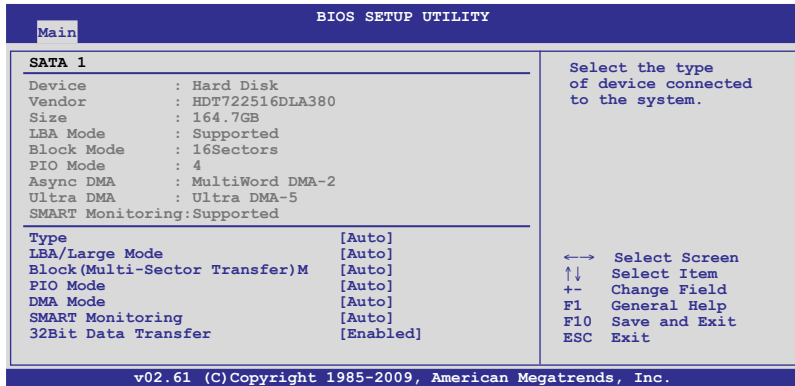

The BIOS automatically detects the values opposite the dimmed items (Device, Vendor, Size, LBA Mode, Block Mode, PIO Mode, Async DMA, Ultra DMA, and SMART monitoring). These values are not user-configurable. These items show N/A if no IDE device is installed in the system.

#### Type [Auto]

Allows you to select the type of SATA drive installed.

[Not Installed] Select this option if no SATA drive is installed.

[Auto] Allows automatic selection of the appropriate SATA device type.

[CDROM] Select this option if you are specifically configuring a CD-ROM drive.

[ARMD] Select [ARMD] (ATAPI Removable Media Device) if your device is either a ZIP, LS-120, or MO drive.

#### LBA/Large Mode [Auto]

Enables or disables the LBA (Logical Block Addressing) mode.

[Auto] Select [Auto] to enable the LBA mode (Logical Block Addressing mode) if the device supports this mode, and if the device was not previously formatted with LBA mode disabled.

[Disabled] Disables this function.

### **Block (Multi-Sector Transfer) M [Auto]**

Enables or disables data multi-sectors transfers.

[Auto] When set to [Auto], the data transfer from and to the device occurs in multiple sectors at a time if the device supports multi-sector transfer feature.

[Disabled] When set to [Disabled], the data transfer from and to the device occurs one sector at a time.

### **PIO Mode [Auto]**

[Auto] Allows automatic selection of the PIO (Programmed input/output) modes, which correspond to different data transfer rates.

[0] [1] [2] [3] [4] Set the PIO mode to Mode 0, 1, 2, 3, or 4.

### **DMA Mode [Auto]**

DMA (Direct Memory Access) allows your computer to transfer data to and from the hardware devices installed with much less CPU overhead.

The DMA mode consists of SDMA (single-word DMA), MDMA (multi-word DMA), and UDMA (Ultra DMA). Setting to [Auto] allows automatic selection of the DMA mode.

### **SMART Monitoring [Auto]**

[Auto] Allows automatic selection of the S.M.A.R.T (Smart Monitoring, Analysis, and Reporting Technology).

[Enabled] Enables the S.M.A.R.T feature.

[Disabled] Disables the S.M.A.R.T feature.

### **32Bit Data Transfer [Enabled]**

[Enabled] Sets the IDE/SATA controller to combine two 16-bit reads from the hard disk into a single 32-bit double word transfer to the processor. This makes more efficient use of the PCI bus as fewer transactions are needed for the transfer of a particular amount of data.

[Disabled] Disables this function.

### 3.3.5 Storage Configuration

The Storage Configuration menu allows you to configure your storage devices. Select an item then press <Enter> to display the submenu.

BIOS SETUP UTILITY	
Main	
<b>Storage Configuration</b>	
SATA Configuration [Enhanced]	
Configure SATA as [IDE]	
Hard Disk Write Protect [Disabled]	
IDE Detect Time Out (Sec) [35]	
	<b>Options</b>
	Disabled
	Compatible
	Enhanced

#### SATA Configuration [Enhanced]

Configuration options: [Disabled] [Compatible] [Enhanced]

##### *Configure SATA as [IDE]*

Sets the configuration for the Serial ATA connectors supported by the PCH chip. Configuration options: [IDE] [RAID] [AHCI]



- If you want to use the Serial ATA hard disk drives as Parallel ATA physical storage devices, keep the default setting [IDE].
- If you want the Serial ATA hard disk drives to use the Advanced Host Controller Interface (AHCI), set this item to [AHCI]. The AHCI allows the onboard storage driver to enable advanced Serial ATA features that increases storage performance on random workloads by allowing the drive to internally optimize the order of commands.
- If you want to create a RAID 0, RAID 1, RAID 5, RAID 10, or the Intel® Matrix Storage Technology configuration from the Serial ATA hard disk drives, set this item to [RAID].

#### SB RAID Boot ROM [Auto]

This item appears only you set **Configure SATA as** to [RAID]

Configuration options: [Auto] [Enabled] [Disabled]

#### Hard Disk Write Protect [Disabled]

Disables or enables device write protection. This will be effective only if the device is accessed through BIOS. Configuration option: [Disabled] [Enabled]

#### IDE Detect Time Out (Sec) [35]

Selects the time out value for detecting ATA/ATAPI devices. Configuration options: [0] [5] [10] [15] [20] [25] [30] [35]

### 3.3.6 AHCI Configuration

This menu is the section for AHCI configuration. It appears only when you set the item **Configure SATA as** from the sub-menu of **SATA Configuration** to **[AHCI]**.

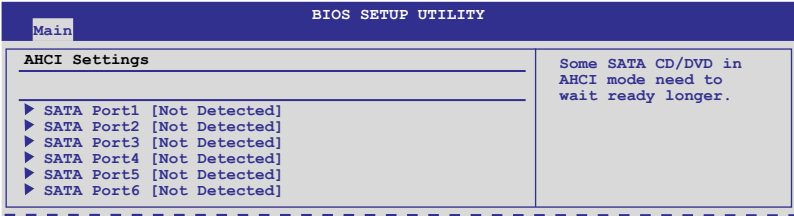

### SATA Port1–6 [XXXX]

Displays the status of auto-detection of SATA devices.

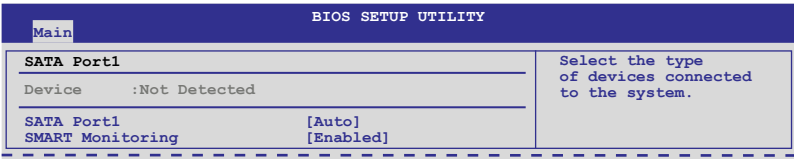

#### *SATA Port1 [Auto]*

Allows you to select the type of device connected to the system.

Configuration options: [Auto] [Not Installed]

#### *SMART Monitoring [Enabled]*

Allows you to set the Self-Monitoring, Analysis and Reporting Technology.

Configuration options: [Disabled] [Enabled]

### 3.3.7 System Information

This menu gives you an overview of the general system specifications. The BIOS automatically detects the BIOS information, CPU specification, and system memory in this menu.



The displayed memory size may differ according to the installed CPU.

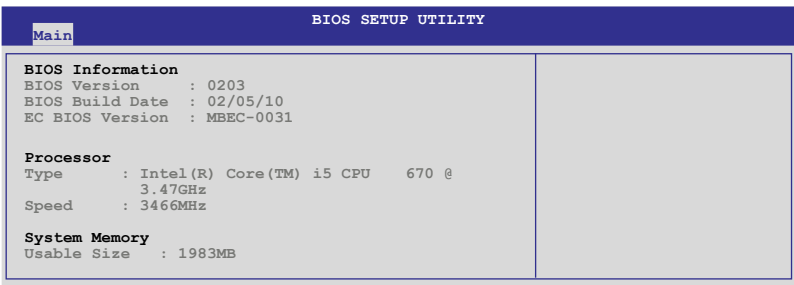

## 3.4 Ai Tweaker menu

The Ai Tweaker menu items allow you to configure overclocking-related items.



Take caution when changing the settings of the **Ai Tweaker** menu items. Incorrect field values can cause the system to malfunction.



The default values of the following items vary depending on the CPU and memory modules you install on the motherboard.

BIOS SETUP UTILITY	
Main	Ai Tweaker
<b>Configure System Performance Settings</b>	
Target CPU Frequency: 2793MHz Target DRAM Frequency: 1333MHz	
CPU Level Up	[Auto]
-----	
Ai Overclock Tuner	[Auto]
CPU Ratio Setting	[22.0]
Intel (R) SpeedStep(TM) Tech	[Enabled]
Intel (R) TurboMode tech	[Enabled]
Xtreme Phase Full Power Mode	[Auto]
DRAM Frequency	[Auto]
QPI Frequency	[Auto]
ASUS/3rd Party UI Priority	[ASUS Utility]
OC Tuner	[Turbo Profile]
Start auto tuning	
▶ DRAM Timing Control	

Warning: this function belongs to overclocking, and it may cause instability.  
Select a CPU level, and the rest will be auto-adjusted. If you want to adjust more, set Ai Overclock Tuner to Manual after you select a CPU level.

←→ Select Screen  
↑↓ Select Item  
+ - Change Field  
F1 General Help  
F10 Save and Exit  
ESC Exit

v02.61 (C) Copyright 1985-2009, American Megatrends, Inc.

Scroll down to display the following items:

CPU Differential Amplitude	[Auto]
CPU Clock Skew	[Auto]
***** Please key in numbers directly! *****	
CPU Voltage Mode	[Offset]
Offset Voltage	[Auto]
Current CPU Core Voltage	[ 1.200V]
IMC Voltage	[Auto]
Current IMC Voltage	[ 1.106V]
DRAM Voltage	[Auto]
Current DRAM Voltage	[ 1.506V]
CPU PLL Voltage	[Auto]
Current CPU PLL Voltage	[ 1.896V]
PCH Voltage	[Auto]
Current PCH Voltage	[ 1.050V]
*****	
Load-Line Calibration	[Auto]
CPU Spread Spectrum	[Auto]
PCIe Spread Spectrum	[Auto]

←→ Select Screen  
↑↓ Select Item  
+ - Change Option  
F1 General Help  
F10 Save and Exit  
ESC Exit

v02.61 (C) Copyright 1985-2009, American Megatrends, Inc.

### 3.4.1 CPU Level Up [Auto]

Allows you to select a CPU level, and the related parameters will be automatically adjusted according to the selected CPU level. If you want to manually configure the settings in detail, set **Ai Overclock Tuner** to [Manual] after selecting a CPU level. Configuration options: [Auto] [i3-530-2.93G] [i3-540-3.06G] [i5-650-3.2G]



---

The available configuration options differ by the installed CPU.

---

### 3.4.2 Ai Overclock Tuner [Auto]

Allows selection of CPU overclocking options to achieve desired CPU internal frequency. Select either one of the preset overclocking configuration options:

<b>Manual</b>	Allows you to individually set overclocking parameters.
<b>Auto</b>	Loads the optimal settings for the system.
<b>D.O.C.P</b>	Overclocks DRAM frequency by adjusting BCLK frequency.
<b>X.M.P.</b>	If you install memory module(s) supporting the eXtreme Memory Profile (X.M.P.) Technology, choose this item to set the profile(s) supported by your memory module(s) for optimizing the system performance.
<b>CPU Level Up</b>	CPU Level Up



---

The configuration options for the following sub-item vary depending on the DIMMs you install on the motherboard.

---

#### *DRAM O.C. Profile [DDR3-1600MHz]*

This item appears only when you set the **Ai Overclock Tuner** item to [D.O.C.P.] and allows you to select a DRAM O.C. profile, which applies different settings to DRAM frequency, DRAM timing and DRAM voltage. Configuration options: [DDR3-1600MHz] [DDR3-1800MHz] [DDR3-1866MHz]

#### *eXtreme Memory Profile [Disabled]*

This item appears only when you set the **Ai Overclock Tuner** item to [X.M.P.] and allows you to select the X.M.P. mode supported by your memory module. Configuration options: [High Performance] [High Frequency]



---

To obtain the best performance of the X.M.P. DIMM or 1600MHz DIMM, install only one DIMM on each memory channel.

---

### 3.4.3 CPU Ratio Setting [Auto]

Allows you to adjust the ratio between CPU Core Clock and BCLK Frequency. Use the <+> and <-> keys to adjust the value. The valid value ranges differently according to your CPU model.



### 3.4.4 Intel(R) SpeedStep (TM) Tech. [Enabled]

Allows you to use the Enhanced Intel SpeedStep® Technology (EIST).

[Enabled] Enables the EIST function.

[Disabled] Disables this function.

### 3.4.5 Intel(R) TurboMode Tech [Enabled]

This item appears only if you set the **Ratio CMOS Setting** item to [Auto]. Turbo mode allows processor cores to run faster than marked frequency in specific condition. Configuration options: [Disabled] [Enabled]

### 3.4.6 Xtreme Phase Full Power Mode [Auto]

Enable this item to ensure the best CPU O.C. performance.

Configuration options: [Auto] [Enabled]



---

The following item appears only when you set the **Ai Overclock Tuner** item to [Manual], [D.O.C.P.] or [X.M.P.].

---

### BCLK Frequency [XXX]

Allows you to adjust the Internal Base Clock (BCLK). Use the <+> and <-> keys to adjust the value. You can also type the desired value using the numeric keypad. The values range from 80 to 500.

### 3.4.7 DRAM Frequency [Auto]

Allows you to set the DDR3 operating frequency.

Configuration options: [Auto] [DDR3-800MHz] [DDR3-1066MHz] [DDR3-1333MHz] [DDR3-1600MHz]



---

The **DRAM Frequency** configuration options vary with the **BCLK Frequency** item settings.

---



---

Selecting a very high DRAM frequency may cause the system to become unstable! If this happens, revert to the default setting.

---

### 3.4.8 QPI Frequency [Auto]

Configuration options: [Auto] [4270MHz] [4800MHz]

### 3.4.9 ASUS/3rd Party UI Priority [ASUS Utility]

Allows you to decide the priority of overclocking utilities. When you set this item to [ASUS Utility], other third party overclocking utilities may not function fully and vice versa. Configuration options: [ASUS Utility] [3rd Party Utility]

### 3.4.10 OC Tuner [Turbo Profile]

Set an auto-adjustment limit value for OC Tuner Utility.

Configuration options: [Good Performance] [Better Performance] [Turbo Profile]

### 3.4.11 Start auto tuning

Press the <ENTER> key to start automatic system overclocking. The OC Tuner Utility automatically adjust system parameters and reboots several times for the best overclocking result. DO NOT shut down the power before the auto-adjustment completes.

### 3.4.12 DRAM Timing Control [Auto]

The items in this menu allow you to set the DRAM timing control features.



---

The configuration options for some of the following items vary depending on the DIMMs you install on the motherboard.

---

#### 1st Information: 9-9-9-24-4-74-10-5-20

The values vary depending on your settings of the following sub-items:

##### DRAM CAS# Latency [Auto]

Configuration options: [Auto] [3 DRAM Clock] [4 DRAM Clock] – [10 DRAM Clock] [11 DRAM Clock]

##### DRAM RAS# to CAS# Delay [Auto]

Configuration options: [Auto] [3 DRAM Clock] [4 DRAM Clock] – [9 DRAM Clock] [10 DRAM Clock]

##### DRAM RAS# PRE Time [Auto]

Configuration options: [Auto] [3 DRAM Clock] [4 DRAM Clock] – [9 DRAM Clock] [10 DRAM Clock]

##### DRAM RAS# ACT Time [Auto]

Configuration options: [Auto] [3 DRAM Clock] [4 DRAM Clock] – [32 DRAM Clock] [31 DRAM Clock]

##### DRAM RAS# to RAS# Delay [Auto]

Configuration options: [Auto] [1 DRAM Clock] – [7 DRAM Clock]

##### DRAM REF Cycle Time [Auto]

Configuration options: [Auto] [48 DRAM Clock] [60 DRAM Clock] [72 DRAM Clock] [82 DRAM Clock] [88 DRAM Clock] [90 DRAM Clock] [100 DRAM Clock] [110 DRAM Clock] [114 DRAM Clock] [118 DRAM Clock] [122 DRAM Clock] [126 DRAM Clock] [130 DRAM Clock] [134 DRAM Clock] [138 DRAM Clock]

DRAM WRITE Recovery Time [Auto]

Configuration options: [Auto] [1 DRAM Clock] – [15 DRAM Clock]

DRAM READ to PRE Time [Auto]

Configuration options: [Auto] [3 DRAM Clock] – [15 DRAM Clock]

DRAM FOUR ACT WIN Time [Auto]

Configuration options: [Auto] [1 DRAM Clock] – [15 DRAM Clock]

DRAM Timing Mode [Auto]

Configuration options: [Auto] [1N] [2N]

DRAM WRITE to READ Delay(DR) [Auto]

Configuration options: [Auto] [1 DRAM Clock] – [8 DRAM Clock]

DRAM WRITE to READ Delay(SR) [Auto]

Configuration options: [Auto] [10 DRAM Clock] – [22 DRAM Clock]

DRAM READ to WRITE Delay(S/D) [Auto]

Configuration options: [Auto] [2 DRAM Clock] – [14 DRAM Clock]

DRAM READ to READ Delay(DR) [Auto]

Configuration options: [Auto] [2 DRAM Clock] – [9 DRAM Clock]

DRAM READ to READ Delay(SR) [Auto]

Configuration options: [Auto] [4 DRAM Clock] [6 DRAM Clock]

DRAM WRITE to WRITE Delay(DR) [Auto]

Configuration options: [Auto] [2 DRAM Clock] – [9 DRAM Clock]

DRAM WRITE to WRITE Delay(SR) [Auto]

Configuration options: [Auto] [4 DRAM Clock] [6 DRAM Clock]

### **3.4.13 CPU Differential Amplitude [Auto]**

Different AMP might enhance BCLK overclocking ability.

Configuration options: [Auto] [700mV] [800mV] [900mV] [1000mV]

### **3.4.14 CPU Clock Skew [Auto]**

Adjusting this item may help enhancing BCLK overclocking ability. You may need to adjust the **NB Clock Skew** item at the same time.

Configuration options: [Auto] [Normal] [Delay 100ps]–[Delay 1500ps]



---

The following ten (10) items are adjusted by typing the desired values using the numeric keypad and press the <Enter> key. You can also use the <+> and <-> keys to adjust the value. To restore the default setting, type [auto] using the keyboard and press the <Enter> key.

---

### 3.4.15 CPU Voltage Mode [Offset]

Allows you to set the CPU Voltage Mode. Different sub-items appear according to the **CPU Voltage Mode** item setting. Configuration options: [Offset] [Manual]

#### *Offset Voltage [Auto]*

This item appears only when you set the **CPU Voltage Mode** item to [Offset] and allows you to set the Offset voltage. The values range from 0.00625V to 0.50000V with a 0.00625V interval.

#### *Offset Sign [-]*

This item appears only when you set the **Offset Voltage** item to a value other than [Auto].

[+] To offset the voltage by a positive value.

[-] To offset the voltage by a negative value.

#### *Fixed Voltage [Auto]*

This item appears only when you set the **CPU Voltage Mode** item to [Manual] and allows you to set a fixed CPU voltage. The values range from 0.85V to 2.10V\* with a 0.00625V interval.



---

Refer to the CPU documentation before setting the CPU Vcore voltage. Setting a high VCore voltage may damage the CPU permanently, and setting a low VCore voltage may make the system unstable.

---

### 3.4.16 IMC Voltage [Auto]

Allows you to set the CPU Integrated Memory Controller voltage. The values range from 1.1V to 1.97\* with a 0.00625V interval.

### 3.4.17 DRAM Voltage [Auto]

Allows you to set the DRAM voltage. The values range from 1.5V to 2.5V\* with a 0.0125V interval.



---

According to Intel CPU spec, DIMMs with voltage requirement over 1.65V may damage the CPU permanently. We recommend you install the DIMMs with the voltage requirement below 1.65V.

---

### 3.4.18 CPU PLL Voltage [Auto]

Allows you to set the CPU PLL voltage. The values range from 1.8V to 2.1V with a 0.1V interval.

### 3.4.19 PCH Voltage [Auto]

Allows you to set the Platform Controller Hub voltage. The values range from 1.05V to 1.15V with a 0.10V interval.

### 3.4.20 Load-Line Calibration [Auto]

- [Auto] Automatic configuration.
- [Disabled] Follow Intel specifications.
- [Enabled] Improve CPU VDroop directly.

### 3.4.21 CPU Spread Spectrum [Auto]

- [Auto] Automatic configuration.
- [Disabled] Enhances the BCLK overclocking ability.
- [Enabled] Sets to [Enabled] for EMI control.

### 3.4.22 PCIE Spread Spectrum [Auto]

- [Auto] Automatic configuration.
- [Disabled] Enhances the PCIE overclocking ability.
- [Enabled] Sets to [Enabled] for EMI control.

## 3.5 Advanced menu

The Advanced menu items allow you to change the settings for the CPU and other system devices.



The default values of the following items vary depending on the CPU and memory modules you install on the motherboard.

The screenshot shows the BIOS Setup Utility with the 'Advanced' tab selected. The menu options are: CPU Configuration, Uncore Configuration, Onboard Devices Configuration, USB Configuration, and PCI/PnP. Below these, 'Intel VT-d' and 'T.Probe' are both set to [Disabled]. A legend on the right explains navigation: left/right arrows for screen selection, up/down for item selection, Enter for sub-screen, F1 for help, F10 for save and exit, and ESC for exit. The footer reads 'v02.61 (C) Copyright 1985-2009, American Megatrends, Inc.'

### 3.5.1 CPU Configuration

The items in this menu show the CPU-related information that the BIOS automatically detects.



The items shown in this screen may be different due to the CPU you installed.

The screenshot shows the BIOS Setup Utility with the 'Advanced' tab selected, displaying the 'Configure advanced CPU settings' screen. It lists CPU details: Manufacturer: Intel, Brand String: Intel(R) Core(TM) CPU 870, Frequency: 2.80GHz, BCLK Speed: 133MHz, Cache L1: 256 KB, Cache L2: 1024 KB, Cache L3: 8192 KB, Ratio Status: Unlocked (Min:09, Max:21), Ratio Actual Value: 21, and CPUID: 20651. Below this, several settings are listed: Ratio CMOS Setting [Auto], C1E Support [Enabled], Hardware Prefetcher [Enabled], Adjacent Cache Line Prefetch [Enabled], Max CPUID Value Limit [Disabled], and Intel(R) Virtualization Tech [Enabled]. A legend on the right explains navigation: left/right arrows for screen selection, up/down for item selection, Enter for sub-screen, F1 for help, F10 for save and exit, and ESC for exit. The footer reads 'v02.61 (C) Copyright 1985-2009, American Megatrends, Inc.'

Scroll down to display the following items:

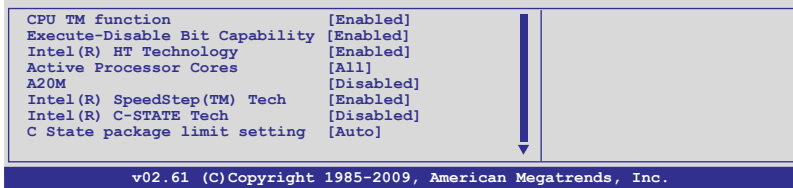

### **CPU Ratio Setting [Auto]**

Allows you to adjust the ratio between CPU Core Clock and BCLK Frequency. Use the <+> and <-> keys to adjust the value. The valid value ranges differently according to your CPU model.

### **C1E Support [Enabled]**

[Enabled] Enables the C1E support function. This item should be enabled in order to enable the Enhanced Halt State.

[Disabled] Disables this function.

### **Hardware Prefetcher [Enabled]**

[Enabled] Enables the Hardware Prefetcher function. This item should be enabled in order to enable the L2 cache (MLC) Streamer Prefetcher for tuning performance of the specific application.

[Disabled] Disables this function.

### **Adjacent Cache Line Prefetcher [Enabled]**

[Enabled] Enables the Adjacent Cache Line Prefetcher function. This item should be enabled in order to enable the L2 cache (MLC) Spatial Prefetcher for tuning performance of the specific application.

[Disabled] Disables this function.

### **Max CPUID Value Limit [Disabled]**

[Enabled] Allows legacy operating systems to boot even without support for CPUs with extended CPUID functions.

[Disabled] Disables this function.

### **Intel(R) Virtualization Tech [Enabled]**

[Enabled] Allows a hardware platform to run multiple operating systems separately and simultaneously, enabling one system to virtually function as several systems.

[Disabled] Disables this function.

### **CPU TM function [Enabled]**

- [Enabled] Enables the overheated CPU to throttle its clock speed to cool down.
- [Disabled] Disables this function.

### **Execute Disable Bit Capability [Enabled]**

- [Enabled] Enables the No-Execution Page Protection Technology.
- [Disabled] Forces the XD feature flag to always return to zero (0).

### **Intel(R) HT Technology [Enabled]**

- [Enabled] Enables the Intel Hyper-Threading Technology.
- [Disabled] Only one thread per activated CPU core is enabled.

### **Active Processor Cores [All]**

- [All] Activate all CPU cores in the processor package.
- [1] Activate only 1 CPU core in the processor package.
- [2] Activate 2 CPU cores in the processor package.

### **A20M [Disabled]**

- [Enabled] Legacy OSes and APs may need this function enabled.
- [Disabled] Disables this function.

### **Intel(R) SpeedStep (TM) Tech [Enabled]**

- [Enabled] The CPU speed is controlled by the operating system.
- [Disabled] The CPU runs at its default speed.

### **Intel(R) C-STATE Tech [Enabled]**

- [Enabled] Allows the CPU to save more power under idle mode. Enable this item only when you install a C-State Technology-supported CPU.
- [Disabled] Disables this function.

### **C State package limit setting [Auto]**

This item appears only when you set the **Intel(R) C-STATE Tech** item to [Enabled]. We recommend that you set this item to [Auto] for BIOS to automatically detect the C-State mode supported by your CPU.

Configuration options: [Auto] [C1] [C3] [C6]



### 3.5.2 Uncore Configuration

The Uncore Configuration menu allows you to change the advanced chipset settings.

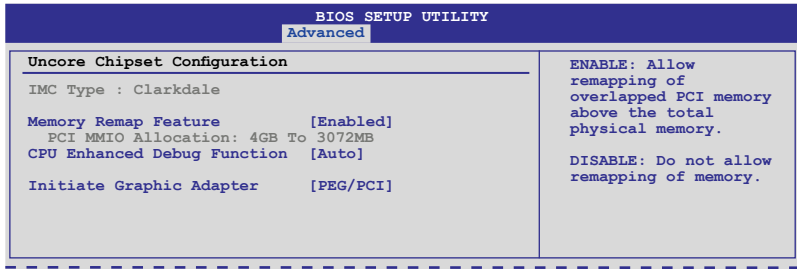

#### Memory Remap Feature [Enabled]

[Disabled] Do not allow remapping of memory.

[Enabled] Allows for the segment of system memory that was previously overwritten by PCI devices to be remapped above the total physical memory.

#### CPU Enhanced Debug Function [Auto]

[Auto] Enables Intel Enhanced Debug if the CPU supports this function.

[Enabled] Supports Intel Enhanced Debug.

[Disabled] Disables Intel Enhanced Debug and frees some memory.

#### Initiate Graphic Adapter [PEG/PCI]

Configuration options: [iGPU] [PCI/iGPU] [PCI/PEG] [PEG/iGPU] [PEG/PCI]

### 3.5.3 Onboard Devices Configuration

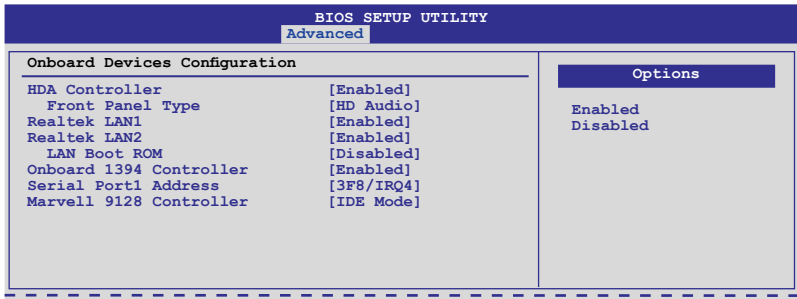

#### HDA Controller [Enabled]

[Enabled] Enables the High Definition Audio Controller.

[Disabled] Disables the controller.

#### *Front Panel Type [HD Audio]*

[AC97] Set the front panel audio connector (AAFP) mode to legacy AC'97.

[HD Audio] Set the front panel audio connector (AAFP) mode to high-definition audio.

#### Realtek LAN1/2 [Enabled]

[Enabled] Enables Realtek LAN Controller 1/2.

[Disabled] Disables Realtek LAN Controller 1/2.

#### *LAN Boot ROM [Disabled]*

This item appears only when you enable the previous item(s).

[Disabled] Disables Realtek LAN Boot ROM.

[Enabled] Enables Realtek LAN Boot ROM.

#### Onboard 1394 Controller [Enabled]

[Enabled] Enables the onboard 1394 Controller.

[Disabled] Disables the controller.

#### Serial Port1 Address [3F8/IRQ4]

Allows you to select the Serial Port1 base address.

Configuration options: [Disabled] [3F8/IRQ4] [2F8/IRQ3] [3E8/IRQ4] [2E8/IRQ3]

#### Marvell 9128 Controller [IDE Mode]

Allows you to select the Marvell 9128 controller operate mode.

Configuration options: [Disabled] [IDE Mode] [AHCI Mode]



You have to manually install the Marvell RAID Utility (MRU) when this item is set to [IDE Mode].

### 3.5.4 USB Configuration

The items in this menu allows you to change the USB-related features. Select an item then press <Enter> to display the configuration options.

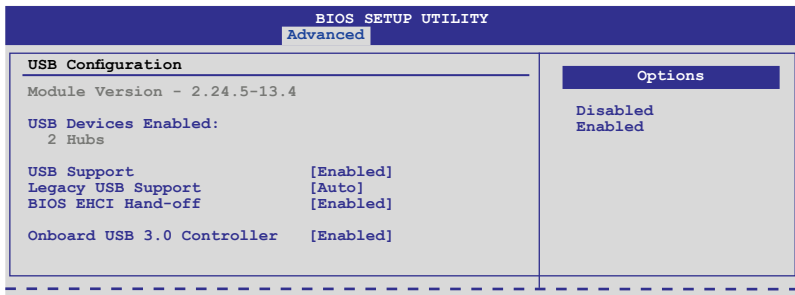

The **USB Devices Enabled** item shows the auto-detected values. If no USB device is detected, the item shows None.

#### USB Support [Enabled]

[Enabled] Enables the USB Host Controllers.

[Disabled] Disables the controllers.



The following items appear only when you set **USB Functions** to [Enabled].

#### Legacy USB Support [Auto]

[Auto] Allows the system to detect the presence of USB devices at startup. If detected, the USB controller legacy mode is enabled. If no USB device is detected, the legacy USB support is disabled.

[Enabled] Enables the support for USB devices on legacy operating systems (OS).

[Disabled] Disables the function.

#### BIOS EHCI Hand-off [Enabled]

[Enabled] Enables the support for operating systems without an EHCI hand-off feature.

[Disabled] Disables the function.

#### Onboard USB 3.0 Controller [Enabled]

[Enabled] Enables the USB 3.0 function.

[Disabled] Disables the function.

### 3.5.5 PCIPnP

The PCIPnP menu items allow you to change the advanced settings for PCI/PnP devices.



Take caution when changing the settings of the PCI PnP menu items. Incorrect field values can cause the system to malfunction.

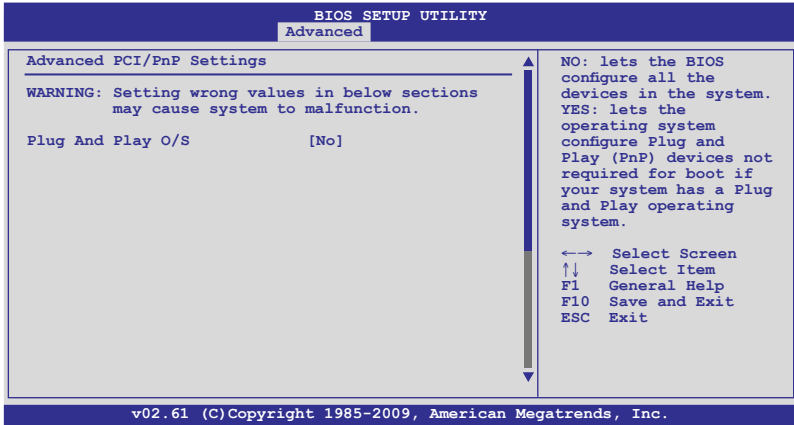

#### Plug And Play O/S [No]

- [Yes] When set to [Yes] and if you install a Plug and Play operating system, the operating system configures the Plug and Play devices not required for boot.
- [No] When set to [No], BIOS configures all the devices in the system.

### 3.5.6 Intel VT-d [Disabled]

- [Disabled] Disables the Intel Virtualization Technology for Directed I/O.
- [Enabled] Enables the Intel Virtualization Technology for Directed I/O.

### 3.5.7 T.Probe [Disabled]

- [Disabled] Disables the T.Probe Functions.
- [Enabled] Enables the T.Probe Functions.

## 3.6 Power menu

The Power menu items allow you to change the settings for the Advanced Power Management (APM). Select an item then press <Enter> to display the configuration options.



The default values of the following items vary depending on the CPU and memory modules you install on the motherboard.

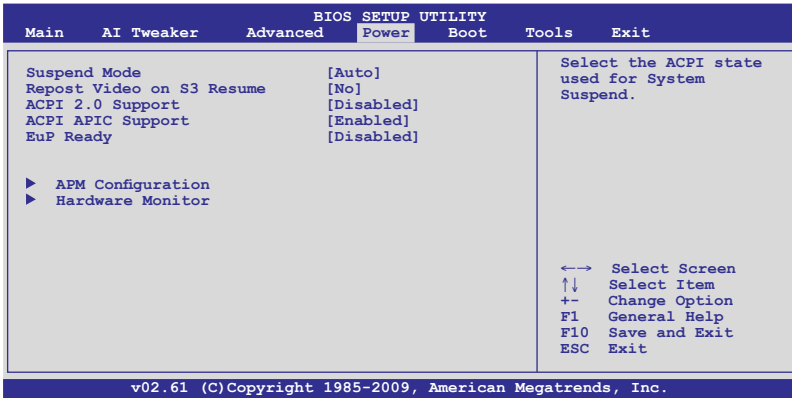

### 3.6.1 Suspend Mode [Auto]

Allows you to select the Advanced Configuration and Power Interface (ACPI) state to be used for system suspend.

[S1 (POS) only] Sets the ACPI suspend mode to S1/POS (Power On Suspend).

[S3 only] Sets the ACPI suspend mode to S3/STR (Suspend To RAM).

[Auto] The system automatically configures the ACPI suspend mode.

### 3.6.2 Repost Video on S3 Resume [No]

Determines whether to invoke VGA BIOS POST on S3/STR resume.

[No] When set to [No], the system will not invoke VGA BIOS POST on S3/STR resume.

[Yes] When set to [Yes], the system invokes VGA BIOS POST on S3/STR resume.

### 3.6.3 ACPI 2.0 Support [Disabled]

[Disabled] When set to [Disabled], the system will not add additional tables as per ACPI 2.0 specifications.

[Enabled] When set to [Enabled], the system adds additional tables as per ACPI 2.0 specifications.

### 3.6.4 ACPI APIC Support [Enabled]

Allows you to enable or disable the Advanced Configuration and Power Interface (ACPI) support in the Advanced Programmable Interrupt Controller (APIC).

[Disabled] When set to [Disabled], the system disable the Advanced Configuration and Power Interface (ACPI) support in the Advanced Programmable Interrupt Controller (APIC).

[Enabled] When set to [Enabled], the ACPI APIC table pointer is included in the RSDT pointer list.

### 3.6.5 EuP Ready [Disabled]

[Disabled] Disables the Energy Using Products (EuP) Ready function.

[Enabled] Allows BIOS to switch off some power at S5 state to get system ready for the EuP requirement. When set to [Enabled], power for WOL, WO\_USB, audio and onboard LEDs will be switched off at S5 state.

### 3.6.6 APM Configuration

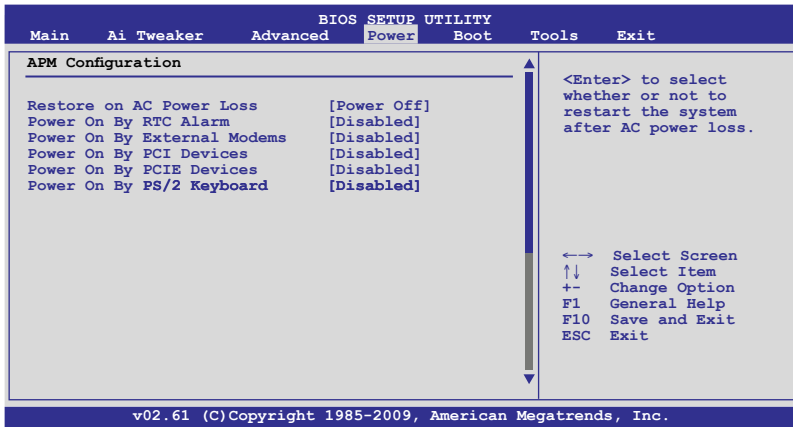

#### Restore On AC Power Loss [Power Off]

[Power Off] The system goes into off state after an AC power loss.

[Power On] The system goes into on state after an AC power loss.

[Last State] The system goes into either off or on state, whatever the system state was before the AC power loss.

### **Power On By RTC Alarm [Disabled]**

- [Disabled] Disables RTC to generate a wake event.
- [Enabled] When set to [Enabled], the items **RTC Alarm Date (Days) / System Time** will become user-configurable with set values.

### **Power On By External Modems [Disabled]**

- [Disabled] Disables to power up the computer when the external modem receives a call while the computer is in Soft-off mode.
- [Enabled] The computer could be powered up when the external modem receives a call while the computer is in Soft-off mode.



---

The computer cannot receive or transmit data until the computer and applications are fully running. Thus, connection cannot be made on the first try. Turning an external modem off and then back on while the computer is off causes an initialization string that turns the system power on.

---

### **Power On By PCI Devices [Disabled]**

- [Disabled] Disables the PME to wake up from S5 by PCI devices.
- [Enabled] Allows you to turn on the system through a PCI LAN or modem card. This feature requires an ATX power supply that provides at least 1A on the +5VSB lead.

### **Power On By PCIE Devices [Disabled]**

Allows you to enable or disable the PCIE devices to generate a wake event.

- [Disabled] Disables the PCIE devices to generate a wake event.
- [Enabled] Enables the PCIE devices to generate a wake event.

### **Power On By PS/2 Keyboard [Disabled]**

- [Disabled] Disables the Power On by a PS/2 keyboard.
- [Space Bar] Sets <Space Bar> on the PS/2 keyboard to turn on the system. This feature requires an ATX power supply that provides at least 1A on the +5VSB lead.
- [Ctrl-Esc] Sets <Ctrl>+<Esc> on the PS/2 keyboard to turn on the system. This feature requires an ATX power supply that provides at least 1A on the +5VSB lead.
- [Power Key] Sets <Power Key> on the PS/2 keyboard to turn on the system. This feature requires an ATX power supply that provides at least 1A on the +5VSB lead.

### 3.6.7 Hardware Monitor

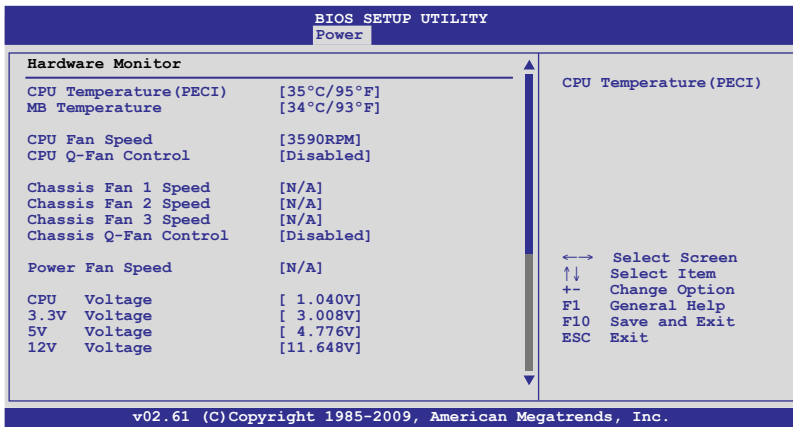

#### CPU/MB Temperature [xxx°C/xxx°F]

The onboard hardware monitor automatically detects and displays the CPU and motherboard temperatures. Select **Ignored** if you do not wish to display the detected temperatures.

#### CPU Fan Speed [xxxxRPM] or [Ignored] / [N/A] Chassis Fan 1/2/3 Speed [xxxxRPM] or [Ignored] / [N/A] Power Fan Speed [xxxxRPM] or [Ignored] / [N/A]

The onboard hardware monitor automatically detects and displays the CPU, chassis, and power fan speed in rotations per minute (RPM). If the fan is not connected to the motherboard, the field shows **N/A**. Select **Ignored** if you do not wish to display the detected speed.

#### CPU Q-Fan Control [Disabled]

- [Disabled] Disables the CPU Q-Fan control feature.
- [Enabled] Enables the CPU Q-Fan control feature.

#### *CPU Fan Profile [Standard]*

This item appears only when you enable the **CPU Q-Fan Control** feature and allows you to set the appropriate performance level of the CPU fan.

- [Standard] Sets to [Standard] to make the CPU fan automatically adjust depending on the CPU temperature.
- [Silent] Sets to [Silent] to minimize the fan speed for quiet CPU fan operation.
- [Turbo] Set to [Turbo] to achieve maximum CPU fan speed.
- [Manual] Set to [Manual] to manually adjust the CPU temperature and fan speed.



**CPU Upper Temperature [70°C/158°F]**

Allows you to set the maximum CPU temperature upper limit. When the CPU temperature reaches the limit, the CPU fan will run at the maximum duty cycle.

Configuration options: [40°C/104°F] [50°C/122°F] [60°C/140°F] [70°C/158°F] [80°C/176°F] [90°C/194°F]

**CPU Fan Max. Duty Cycle [100%]**

Allows you to set the maximum CPU fan duty cycle. When the CPU temperature reaches the limit, the CPU fan will run at the maximum duty cycle.

Configuration options: [20%] [30%] [40%] [50%] [60%] [70%] [80%] [90%] [100%]

**CPU Fan Min. Duty Cycle [20%]**

Allows you to set the minimum CPU fan duty cycle when the CPU temperature is 40°C/104°F or lower.

Configuration options: [20%] [30%] [40%] [50%] [60%] [70%] [80%] [90%] [100%]

**Chassis Q-Fan Control [Disabled]**

[Disabled] Disables the Chassis Q-Fan control feature.

[Enabled] Enables the Chassis Q-Fan control feature.

***Chassis Fan Profile [Standard]***

This item appears only when you enable the **Chassis Q-Fan Control** feature and allows you to set the appropriate performance level of the chassis fan.

[Standard] Sets to [Standard] to make the chassis fan automatically adjust depending on the chassis temperature.

[Silent] Sets to [Silent] to minimize the fan speed for quiet chassis fan operation.

[Turbo] Set to [Turbo] to achieve maximum chassis fan speed.

**CPU Voltage, 3.3V Voltage, 5V Voltage, 12V Voltage**

The onboard hardware monitor automatically detects the voltage output through the onboard voltage regulators. Select **Ignored** if you do not want to detect this item.

## 3.7 Boot menu

The Boot menu items allow you to change the system boot options. Select an item then press <Enter> to display the sub-menu.



The default values of the following items vary depending on the CPU and memory modules you install on the motherboard.

BIOS SETUP UTILITY						
Main	Ai Tweaker	Advanced	Power	Boot	Tools	Exit
<b>Boot Settings</b>						
▶ Boot Device Priority						
▶ Boot Settings Configuration						
▶ Security						
		Specifies the Boot Device Priority sequence.				
		A virtual floppy disk drive (Floppy Drive B: ) may appear when you set the CD-ROM drive as the first boot device.				
		←→ Select Screen ↑↓ Select Item Enter Go to Sub Screen F1 General Help F10 Save and Exit ESC Exit				
v02.61 (C) Copyright 1985-2009, American Megatrends, Inc.						

### 3.7.1 Boot Device Priority

BIOS SETUP UTILITY	
Boot	
<b>Boot Device Priority</b>	
1st Boot Device	[Hard Drive]
2nd Boot Device	[Removable Dev.]
3rd Boot Device	[ATAPI CD-ROM]
Specifies the boot sequence from the available devices.	
A device enclosed in parenthesis has been disabled in the corresponding type menu.	
←→ Select Screen ↑↓ Select Item Enter Go to Sub Screen F1 General Help F10 Save and Exit ESC Exit	
v02.61 (C) Copyright 1985-2009, American Megatrends, Inc.	

#### 1st–xth Boot Device [xxx Drive]

These items specify the boot device priority sequence from the available devices. The number of device items that appears on the screen depends on the number of devices installed in the system. Configuration options: [xxx Drive] [Disabled]

### 3.7.2 Hard Disk Drives; CDROM Drives

These two items appear only when you install more than two hard disk drives or optical drives to you system. These items allows you to specify the boot priority sequence of the hard disk drives or the optical drives.

### 3.7.3 Boot Settings Configuration

BIOS SETUP UTILITY	
Boot	
<b>Boot Settings Configuration</b>	
Quick Boot	[Enabled]
Full Screen Logo	[Enabled]
AddOn ROM Display Mode	[Force BIOS]
Bootup Num-Lock	[On]
Wait for 'F1' if Error	[Enabled]
Hit 'DEL' Message Display	[Enabled]
POST State LEDs	[Enabled]
Allows BIOS to skip certain tests while booting. This will decrease the time needed to boot the system.	

#### Quick Boot [Enabled]

Allows you to enable or disable the **Quick Boot** function.

[Disabled] When set to [Disabled], BIOS performs all the POST items.

[Enabled] When set to [Enabled], BIOS skips some power on self tests (POST) while booting to decrease the time needed to boot the system.

#### Full Screen Logo [Enabled]

This allows you to enable or disable the full screen logo display feature.

[Enabled] Enables the full screen logo display feature.

[Disabled] Disables the full screen logo display feature.



Set this item to [Enabled] to use the ASUS MyLogo2™ feature.

#### AddOn ROM Display Mode [Force BIOS]

Sets the display mode for option ROM.

[Force BIOS]

[Keep Current] .

#### Bootup Num-Lock [On]

Allows you to select the power-on state for the NumLock.

[On] Sets the power-on state of the NumLock to [On].

[Off] Sets the power-on state of the NumLock to [Off].

#### Wait for 'F1' If Error [Enabled]

When set to [Enabled], the system waits for the <F1> key to be pressed when error occurs.

#### Hit 'DEL' Message Display [Enabled]

When set to [Enabled], the system displays the message "Press DEL to run Setup" during POST.

## POST State LEDs [Enabled]

[Enabled] Turn on onboard device LEDs in the order of the device POST sequence.

[Disabled] Disables this function.

### 3.7.4 Security

The Security menu items allow you to change the system security settings. Select an item then press <Enter> to display the configuration options.

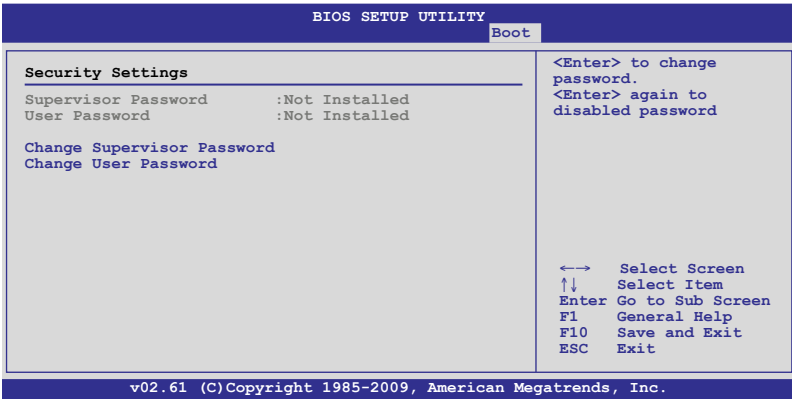

#### Change Supervisor Password

Select this item to set or change the supervisor password. The Supervisor Password item on top of the screen shows the default **Not Installed**. After you set a password, this item shows Installed.

To set a Supervisor Password:

1. Select the **Change Supervisor Password** item and press <Enter>.
2. From the password box, type a password composed of at least six letters and/or numbers, then press <Enter>.
3. Confirm the password when prompted.

The message **Password Installed** appears after you successfully set your password.

To change the supervisor password, follow the same steps as in setting a user password.

To clear the supervisor password, select the **Change Supervisor Password** then press <Enter>. The message **Password Uninstalled** appears.



If you forget your BIOS password, you can clear it by erasing the CMOS Real Time Clock (RTC) RAM. See section **2.6 Jumper** for information on how to erase the RTC RAM.

After you have set a supervisor password, the other items appear to allow you to change other security settings.

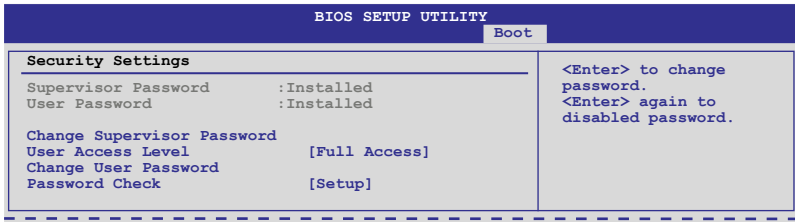

### User Access Level [Full Access]

This item allows you to select the access restriction to the Setup items.

Configuration options: [No Access] [View Only] [Limited] [Full Access]

[No Access] prevents user access to the Setup utility.

[View Only] allows access but does not allow change to any field.

[Limited] allows changes only to selected fields, such as Date and Time.

[Full Access] allows viewing and changing all the fields in the Setup utility.

### Change User Password

Select this item to set or change the user password. The **User Password** item on top of the screen shows the default **Not Installed**. After you set a password, this item shows Installed.

To set a User Password:

1. Select the **Change User Password** item and press <Enter>.
2. On the password box that appears, type a password composed of at least six letters and/or numbers, then press <Enter>.
3. Confirm the password when prompted.

The message **Password Installed** appears after you set your password successfully.

To change the user password, follow the same steps as in setting a user password.

### Password Check [Setup]

When set to [Setup], BIOS checks for user password when accessing the Setup utility. When set to [Always], BIOS checks for user password both when accessing Setup and booting the system. Configuration options: [Setup] [Always]

## 3.8 Tools menu

The Tools menu items allow you to configure options for special functions. Select an item then press <Enter> to display the sub-menu.

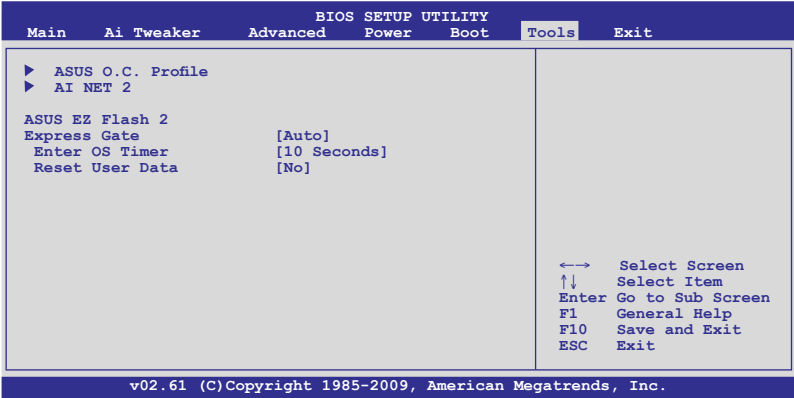

### 3.8.1 ASUS O.C. Profile

This item allows you to store or load multiple BIOS settings.

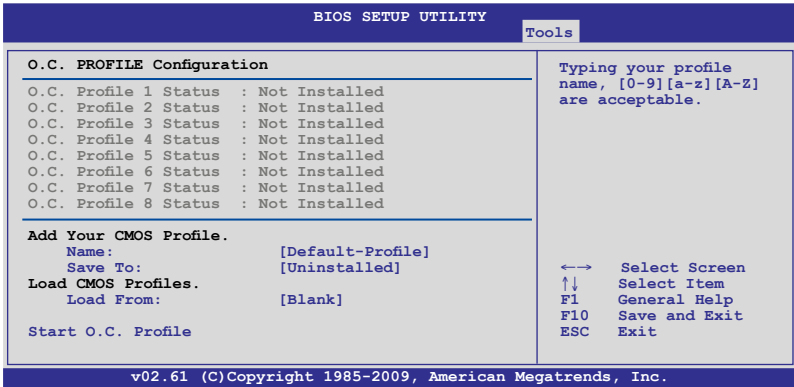

#### Add Your CMOS Profile

Allows you to save the current BIOS file to the BIOS Flash. In the Name sub-item, type your profile name and press <Enter>, and then choose a profile number to save your CMOS settings in the Save to sub-item.

#### Load CMOS Profiles

Allows you to load the previous BIOS settings saved in the BIOS Flash. Press <Enter>, and choose a profile to load.

## Start O.C. Profile

Allows you to run the utility to save and load CMOS. Press <Enter> to run the utility.

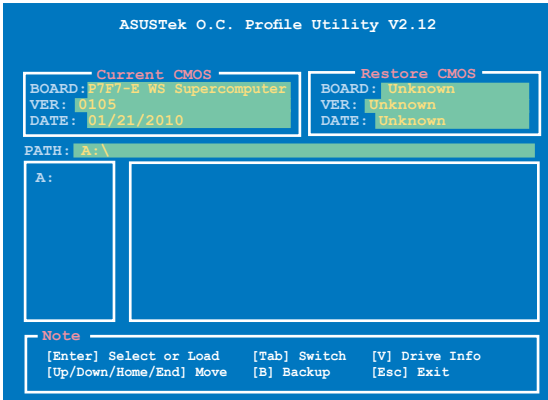

- This function supports devices such as a USB flash disk (FAT 32/16 format) or a floppy disk with single partition only.
- DO NOT shut down or reset the system while updating the BIOS to prevent the system boot failure!
- We recommend that you update the BIOS file only coming from the same memory/CPU configuration and BIOS version.
- Only the CMO file can be loaded.

## 3.8.2 AI NET 2

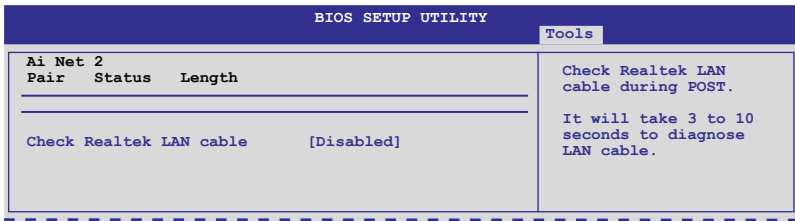

### Check Realtek LAN cable [Disabled]

Enables or disables checking of the LAN cable during the Power-On Self-Test (POST). Configuration options: [Disabled] [Enabled]

### 3.8.3 ASUS EZ Flash 2

Allows you to run ASUS EZ Flash 2. When you press <Enter>, a confirmation message appears. Use the left/right arrow key to select between [Yes] or [No], then press <Enter> to confirm your choice.



---

For more details, refer to **section 3.1.2 ASUS EZ Flash 2 utility**.

---

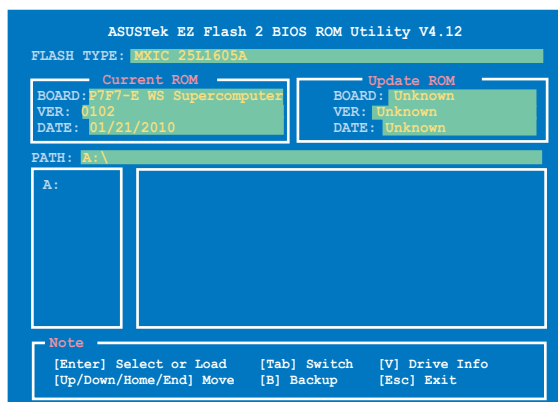

### 3.8.4 Express Gate

Allows you to enable or disable the ASUS Express Gate feature. The ASUS Express Gate feature is a unique instant-on environment that provides quick access to the Internet browser and Skype. Configuration options: [Enabled] [Disabled] [Auto]

#### *Enter OS Timer [10 Seconds]*

Sets countdown duration that the system waits at the Express Gate's first screen before starting Windows or other installed OS. Choose [Prompt User] to stay at the first screen of Express Gate for user action.

Configuration options: [Prompt User] [1 second] [3 seconds] [5 seconds] [10 seconds] [15 seconds] [20 seconds] [30 seconds]



Reset User Data [No]

Allows you to clear Express Gate's user data.

[Reset] When setting this item to [Reset], ensure that you save the setting to the BIOS so that the user data will be cleared the next time you enter the Express Gate. User data includes the Express Gate's settings as well as any personal information stored by the web browser such as bookmarks, cookies, browsing history. This is useful in the rare case where corrupt settings prevent the Express Gate environment from launching properly.

[No] Set to [No] to disable the Reset User Data function when entering the Express Gate.



---

The first time wizard will run again when you enter the Express Gate environment after clearing its settings.

---

# 3.9 Exit menu

The Exit menu items allow you to load the optimal or failsafe default values for the BIOS items, and save or discard your changes to the BIOS items.

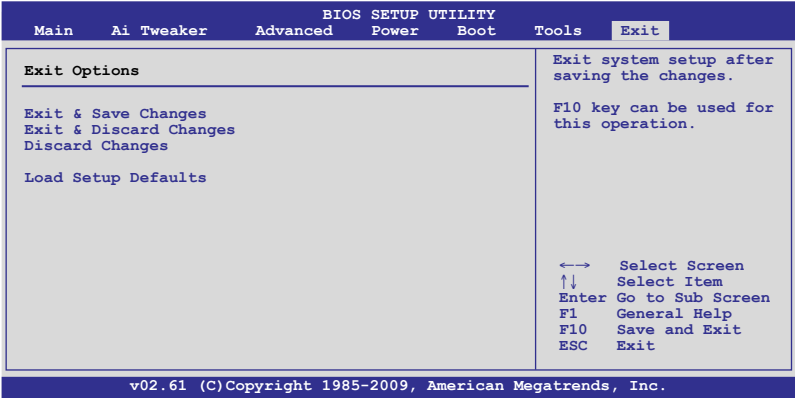

Pressing <Esc> does not immediately exit this menu. Select one of the options from this menu or <F10> from the legend bar to exit.

## Exit & Save Changes

Once you are finished making your selections, choose this option from the Exit menu to ensure the values you selected are saved to the CMOS RAM. An onboard backup battery sustains the CMOS RAM so it stays on even when the PC is turned off. When you select this option, a confirmation window appears. Select YES to save changes and exit.



If you attempt to exit the Setup program without saving your changes, the program prompts you with a message asking if you want to save your changes before exiting. Press <Enter> to save the changes while exiting.

## Exit & Discard Changes

Select this option only if you do not want to save the changes that you made to the Setup program. If you made changes to fields other than System Date, System Time, and Password, the BIOS asks for a confirmation before exiting.

## Discard Changes

This option allows you to discard the selections you made and restore the previously saved values. After selecting this option, a confirmation appears. Select YES to discard any changes and load the previously saved values.

## Load Setup Defaults

This option allows you to load the default values for each of the parameters on the Setup menus. When you select this option or if you press <F5>, a confirmation window appears. Select YES to load default values. Select Exit & Save Changes or make other changes before saving the values to the non-volatile RAM.

This chapter describes the contents of the support DVD that comes with the motherboard package and the software.

# 4 Software support

4.1	Installing an operating system .....	4-1
4.2	Support DVD information .....	4-1
4.3	Software information .....	4-9
4.4	ASUS Unique Overclocking Utility—TurboV EVO.....	4-22
4.5	ASUS GPU Boost .....	4-26
4.6	RAID configurations .....	4-27
4.7	Creating a RAID driver disk.....	4-32

## 4.1 Installing an operating system

This motherboard supports Windows XP/Vista/Win7 operating systems (OS). Always install the latest OS version and corresponding updates to maximize the features of your hardware.



- Motherboard settings and hardware options vary. Use the setup procedures presented in this chapter for reference only. Refer to your OS documentation for detailed information.
- Ensure that you install Windows® XP Service Pack 2 or later versions before installing the drivers for better compatibility and system stability.

## 4.2 Support DVD information

The support DVD that came with the motherboard package contains the drivers, software applications, and utilities that you can install to avail all motherboard features.



The contents of the support DVD are subject to change at any time without notice. Visit the ASUS website at [www.asus.com](http://www.asus.com) for updates.

### 4.2.1 Running the support DVD

Place the support DVD to the optical drive. The DVD automatically displays the Drivers menu if Autorun is enabled in your computer.

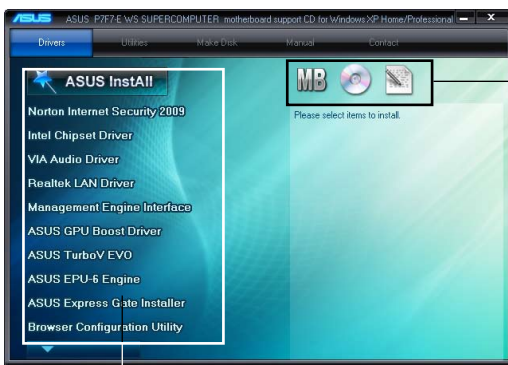

Click an icon to display support DVD/motherboard information

Click an item to install



If Autorun is NOT enabled in your computer, browse the contents of the support DVD to locate the file ASSETUP.EXE from the BIN folder. Double-click the ASSETUP.EXE to run the DVD.

## 4.2.2 Drivers menu

The drivers menu shows the available device drivers if the system detects installed devices. Install the necessary drivers to activate the devices.



Click to display the next screen



Click to display the previous screen

### Norton Internet Security 2009

Installs NIS 2009.

### Intel Chipset Driver

Installs the Intel® chipset drivers.

**VIA Audio Driver**

Installs the VIA® audio Driver.

**Management Engine Interface**

Installs the management Engine Interface.

**Realtek LAN Driver**

Installs the Realtek® Gigabit Ethernet Driver.

**ASUS GPU Booster Driver**

Installs the ASUS GPU Booster driver.

**ASUS TurboV EVO**

Installs ASUS TurboV EVO, the advanced overclocking tool for extreme O.C. record.

**ASUS EPU-6 Engine**

Installs ASUS EPU-6 Engine driver and utility.

**ASUS Express Gate Installer**

Installs ASUS Express Gate.

**Browser Configuration Utility**

Installs the browser configuration utility.

**Marvell 9128 AHCI Driver**

Installs Marvell 9128 AHCI driver.

**USB 3.0 Host Controller Driver**

Installs the USB 3.0 controller driver.

**USB 2.0 Driver**

Installs the USB 2.0 driver.

### 4.2.3 Utilities menu

The Utilities menu shows the applications and other software that the motherboard supports.



#### ASUS Update

The ASUS Update utility allows you to update the motherboard BIOS in Windows® environment. This utility requires an Internet connection either through a network or an Internet Service Provider (ISP).

#### ASUS PC Probe II

This smart utility monitors the fan speed, CPU temperature, and system voltage, and alerts you of any detected problems. This utility helps you keep your computer in healthy operating condition.

#### ASUS AI Suite

Installs the ASUS AI Suite.

#### Realtek Teaming Utility

Installs Realtek Teaming Utility.

#### Adobe Reader 9

Installs the Adobe® Reader that allows you to open, view, and print documents in Portable Document Format (PDF).

#### Marvell RAID Utility

Installs Marvell RAID utility.

#### Microsoft DirectX 9.0c

Installs Microsoft DirectX 9.0c.



## ASUS T Probe

Installs ASUS T Probe.

### 4.2.4 Make disk menu

The Make disk menu contains items to create the Intel and Marvell RAID driver disk.

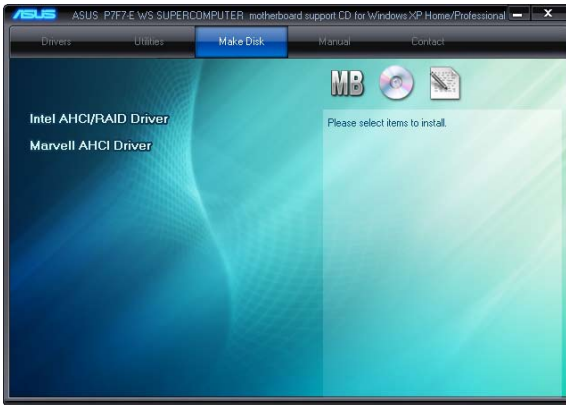

#### Intel AHCI/RAID Driver

Allows you to create an AHCI/RAID Driver disk.

#### Marvell AHCI Driver

Installs Marvell AHCI Driver.

## 4.2.5 Manual menu

The Manuals menu contains a list of supplementary user manuals. Click an item to open the folder of the user manual.



Most user manual files are in Portable Document Format (PDF). Install the Adobe® Acrobat® Reader from the Utilities menu before opening a user manual file.

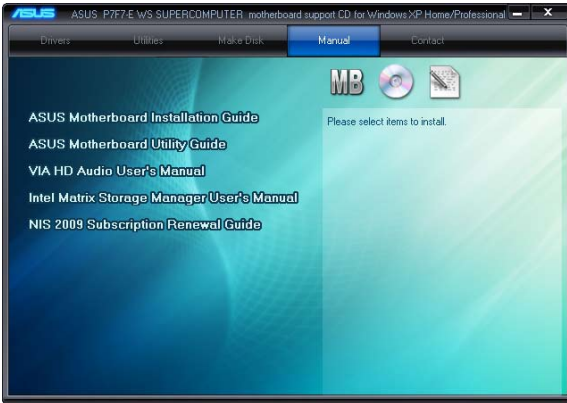

## 4.2.6 ASUS Contact information

Click the Contact tab to display the ASUS contact information. You can also find this information on the inside front cover of this user guide.

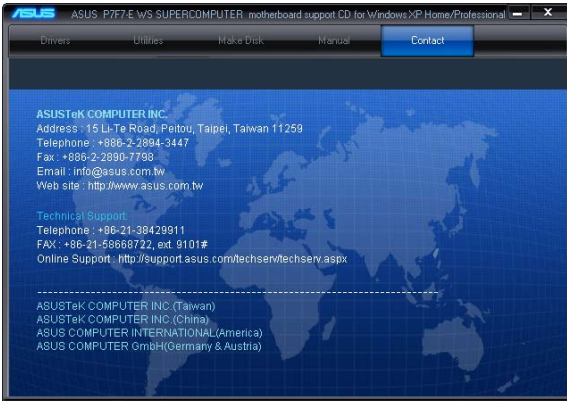

## 4.2.7 Other information

The icons on the top right corner of the screen give additional information on the motherboard and the contents of the support DVD. Click an icon to display the specified information.

### Motherboard Info

Displays the general specifications of the motherboard.

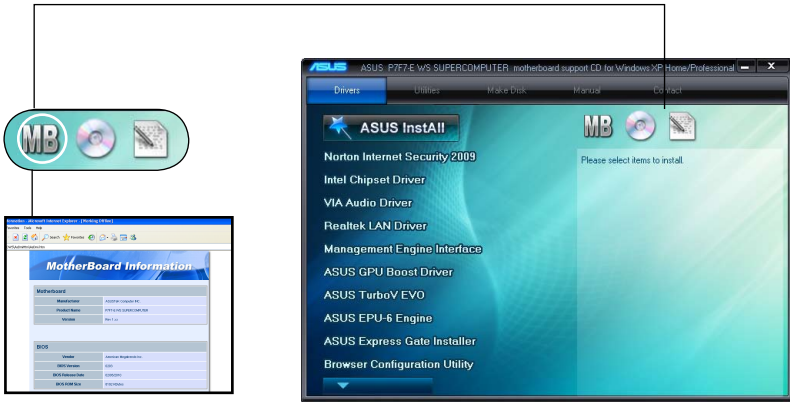

### Browse this DVD

Displays the support DVD contents in graphical format.

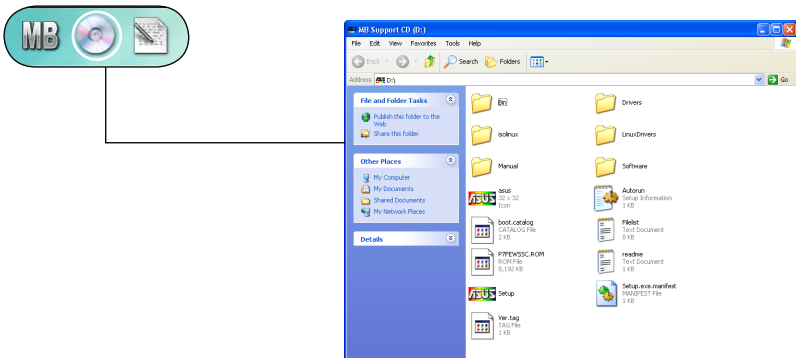

## Filelist

Displays the contents of the support DVD and a brief description of each in text format.

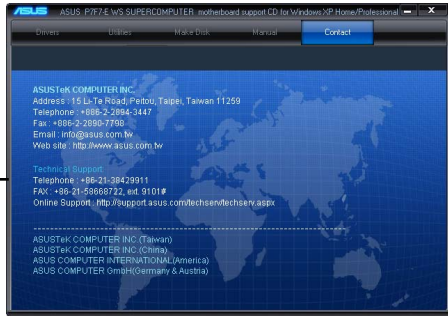
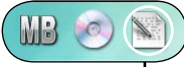

## 4.3 Software information

Most of the applications in the support DVD have wizards that will conveniently guide you through the installation. View the online help or readme file that came with the software application for more information.

### 4.3.1 ASUS PC Probe II

PC Probe II is a utility that monitors the computer's vital components, and detects and alerts you of any problem with these components. PC Probe II senses fan rotations, CPU temperature, and system voltages, among others. Because PC Probe II is software-based, you can start monitoring your computer the moment you turn it on. With this utility, you are assured that your computer is always at a healthy operating condition.

#### Installing PC Probe II

To install PC Probe II on your computer:

1. Place the support DVD to the optical drive. The Drivers installation tab appears if your computer has an enabled Autorun feature.



---

If Autorun is not enabled in your computer, browse the contents of the support DVD to locate the setup.exe file from the ASUS PC Probe II folder. Double-click the **setup.exe** file to start installation.

---

2. Click the **Utilities** tab, then click **ASUS PC Probe II**.
3. Follow the screen instructions to complete installation.

#### Launching PC Probe II

You can launch the PC Probe II right after installation or anytime from the Windows® desktop.

To launch the PC Probe II from the Windows® desktop, click **Start > All Programs > ASUS > PC Probe II > PC Probe II v1.xx.xx**. The PC Probe II main window appears.









After launching the application, the PC Probe II icon appears in the Windows® taskbar. Click this icon to close or restore the application.

#### Using PC Probe II

##### *Main window*

The PC Probe II main window allows you to view the current status of your system and change the utility configuration. By default, the main window displays the Preference section. You can close or restore the Preference section by clicking on the triangle on the main window right handle.



Button	Function
	Opens the Configuration window
	Opens the Report window
	Opens the Desktop Management Interface window
	Opens the Peripheral Component Interconnect window
	Opens the Windows Management Instrumentation window
	Opens the hard disk drive, memory, CPU usage window
	Shows/Hides the Preference section
	Minimizes the application
	Closes the application

### *Sensor alert*

When a system sensor detects a problem, the main window right handle turns red, as the illustrations below show.

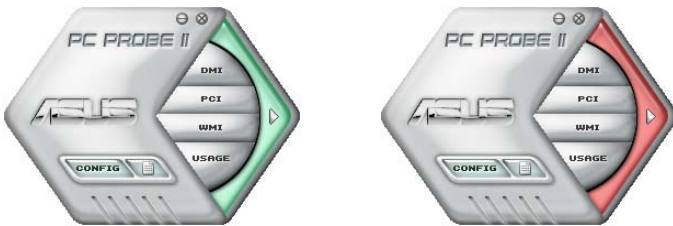

When displayed, the monitor panel for that sensor also turns red. Refer to the Monitor panels section for details.

### **Preferences**

You can customize the application using the Preference section in the main window. Click the box before each preference to activate or deactivate.

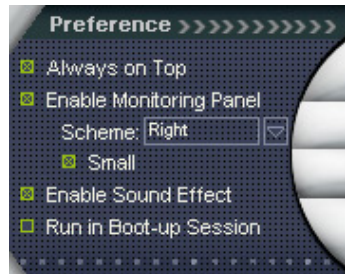

## Hardware monitor panels

The hardware monitor panels display the current value of a system sensor such as fan rotation, CPU temperature, and voltages.

The hardware monitor panels come in two display modes: hexagonal (large) and rectangular (small). When you check the Enable Monitoring Panel option from the Preference section, the monitor panels appear on your computer's desktop.



Large display



Small display

### Changing the monitor panels position

To change the position of the monitor panels in the desktop, click the arrow down button of the Scheme options, then select another position from the list box. Click OK when finished.

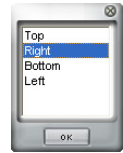

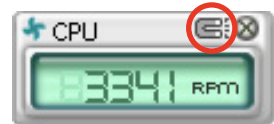

### Moving the monitor panels

All monitor panels move together using a magnetic effect. If you want to detach a monitor panel from the group, click the horseshoe magnet icon. You can now move or reposition the panel independently.



### Adjusting the sensor threshold value

You can adjust the sensor threshold value in the monitor panel by clicking the  or  buttons. You can also adjust the threshold values using the Config window.

You cannot adjust the sensor threshold values in a small monitoring panel.

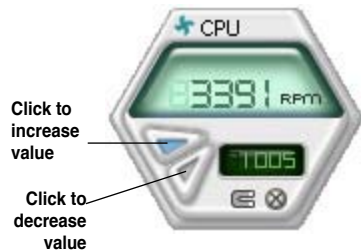

### Monitoring sensor alert

The monitor panel turns red when a component value exceeds or is lower than the threshold value. Refer to the illustrations below.



Large display



Small display

### WMI browser

Click **WMI** to display the WMI (Windows Management Instrumentation) browser. This browser displays various Windows® management information. Click an item from the left panel to display on the right panel. Click the plus sign (+) before WMI Information to display the available information.

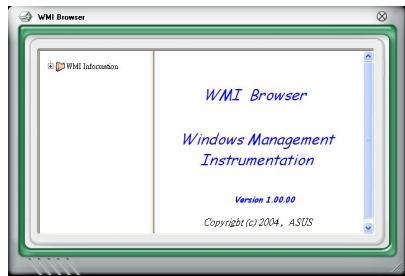

You can enlarge or reduce the browser size by dragging the bottom right corner of the browser.

### DMI browser

Click **DMI** to display the DMI (Desktop Management Interface) browser. This browser displays various desktop and system information. Click the plus sign (+) before DMI Information to display the available information.

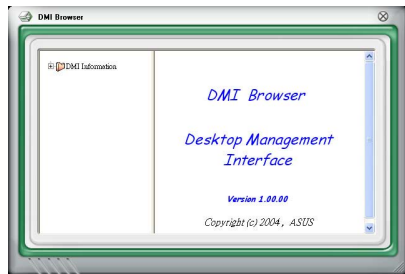



## PCI browser

Click **PCI** to display the PCI (Peripheral Component Interconnect) browser. This browser provides information on the PCI devices installed on your system. Click the plus sign (+) before the PCI Information item to display available information.

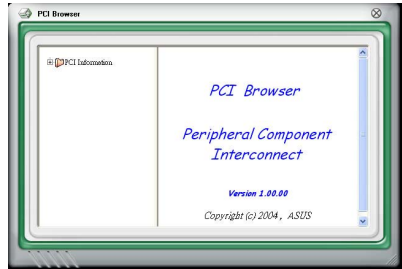

## Usage

The Usage browser displays real-time information on the CPU, hard disk drive space, and memory usage. Click **USAGE** to display the Usage browser.

### CPU usage

The CPU tab displays real-time CPU usage in line graph representation. If the CPU has an enabled Hyper-Threading, two separate line graphs display the operation of the two logical processors.

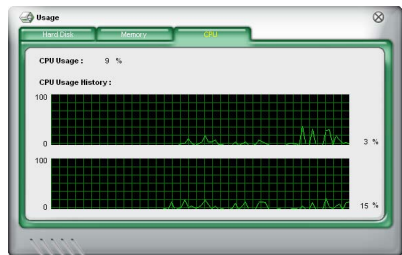

### Hard disk drive space usage

The Hard Disk tab displays the used and available hard disk drive space. The left panel of the tab lists all logical drives. Click a hard disk drive to display the information on the right panel. The pie chart at the bottom of the window represents the used (blue) and the available HDD space.

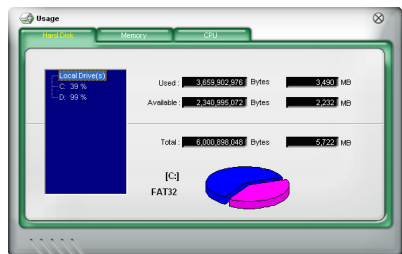

### Memory usage

The Memory tab shows both used and available physical memory. The pie chart at the bottom of the window represents the used (blue) and the available physical memory.

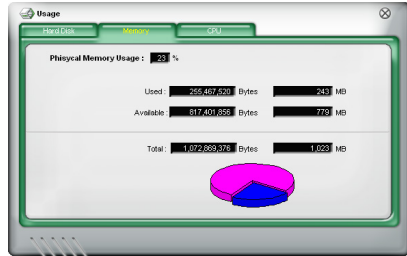

## Configuring PC Probe II

Click  to view and adjust the sensor threshold values.

The Config window has two tabs: Sensor/Threshold and Preference. The Sensor/Threshold tab enables you to activate the sensors or to adjust the sensor threshold values. The Preference tab allows you to customize sensor alerts, or change the temperature scale.

Enabled	Sensor Name	Nominal Value	Current Value	Threshold
<input checked="" type="checkbox"/>	CPU		43	60 °C
<input checked="" type="checkbox"/>	MB		34	45 °C

Default: Loads the default threshold values for each sensor

Apply: Applies your changes

Cancel: Cancels or ignores your changes

Save As: Saves your configuration

Load: Loads your saved configuration

### 4.3.2 ASUS AI Suite

ASUS AI Suite allows you to launch several ASUS utilities easily.

#### Installing AI Suite

To install AI Suite on your computer:

1. Place the support DVD to the optical drive. The Drivers installation tab appears if your computer has an enabled Autorun feature.
2. Click the Utilities tab, then click **AI Suite**.
3. Follow the screen instructions to complete installation.

#### Launching AI Suite

You can launch AI Suite right after installation or anytime from the Windows® desktop.

To launch AI Suite from the Windows® desktop, click **Start > All Programs > ASUS > AI Suite > AI Suite v1.xx.xx**. The AI Suite main window appears.

After launching the application, the AI Suite icon appears in the Windows® notification area. Click this icon to close or restore the application.

#### Using AI Suite

Click each utility button to launch the utility, or click the **Normal** button to restore system default settings.

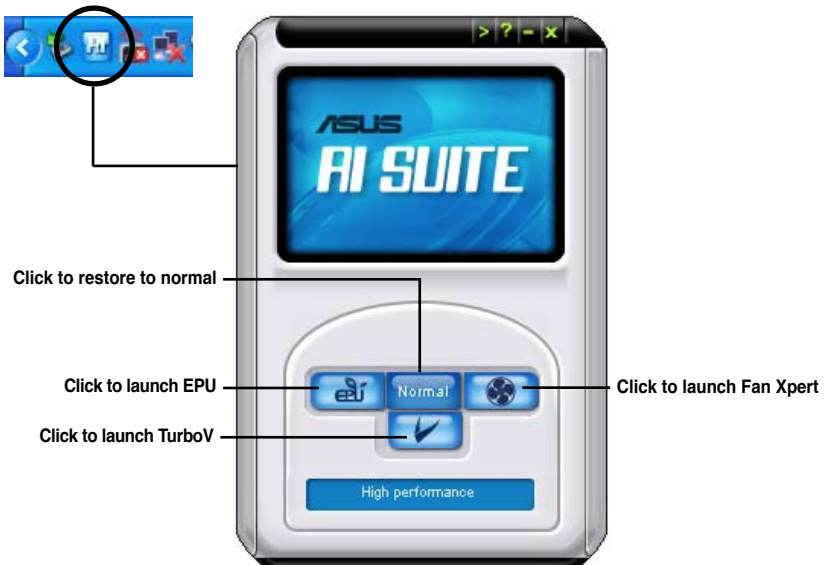

Other feature buttons

Click  on right corner of the main window to open the monitor window.

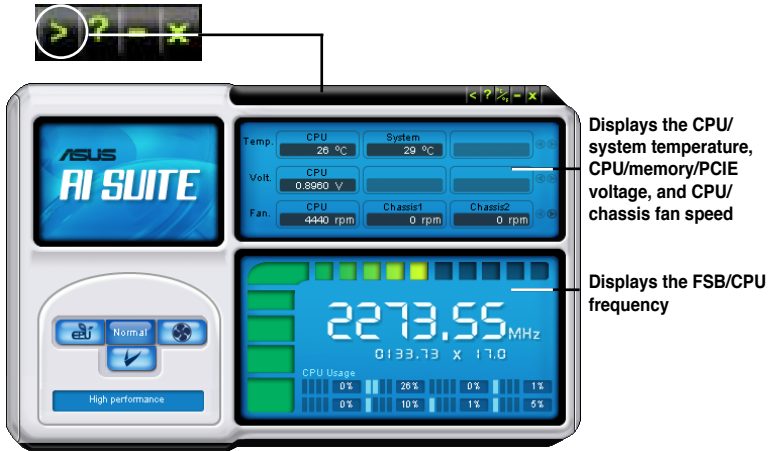

Click  on right corner of the expanded window to switch the temperature from degrees Centigrade to degrees Fahrenheit.



### 4.3.3 ASUS Fan Xpert

Asus Fan Xpert allows you to adjust both the CPU and chassis fan speeds according to different ambient temperatures and your PC's system loading. The various fan profiles offer flexible controls of fan speeds to achieve a quiet and cool system environment.

#### Launching Fan Xpert

After installing AI Suite from the motherboard support DVD, launch Fan Xpert by double-clicking the **AI Suite** tray icon and then clicking the **Fan Xpert** button  on the AI Suite main window.

#### Using Fan Xpert



#### Fan profiles

- **Disable:** disables the **Fan Xpert** function.
- **Standard:** adjusts fan speed in a moderate pattern.
- **Silent:** minimizes fan speed for quiet fan operation.
- **Turbo:** maximizes the fan speed for the best cooling effect.
- **Intelligent:** automatically adjusts the CPU fan speed according to the ambient temperature.
- **Stable:** fixes the CPU fan speed to avoid noise caused by the unsteady fan rotation. The fan will speed up when the temperature exceeds 70°C.
- **User:** Allows you to configure the CPU fan profile under certain limitations.

### 4.3.4 ASUS EPU-6 Engine

ASUS EPU-6 Engine is an energy-efficient tool that satisfies different computing needs. This utility provides four modes that you can select to enhance system performance or save power:

-  **Turbo Mode**
-  **High Performance Mode**
-  **Medium Power Saving Mode**
-  **Max. Power Saving Mode**

Selecting **Auto Mode**  will have the system shift modes automatically according to current system status. You can also customize each mode by configuring settings like CPU frequency, vCore Voltage, and Fan Control.

#### Launching 6 Engine

After installing EPU-6 Engine from the motherboard support DVD, launch the program by double-clicking the 6 Engine tray icon.



The first time you launch 6 Engine, the following message will appear, asking you to run Calibration first. Running calibration allows the system to detect CPU properties to optimize power management.

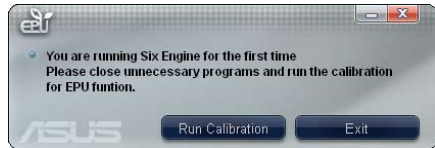

Click **Run Calibration** and wait for a few seconds. Then, the 6 Engine main menu appears.

#### 6 Engine main menu



### 4.3.5 ASUS Express Gate

ASUS Express Gate is an instant-on environment that gives you quick access to the Internet, Skype, and viewing your pictures. Within a few seconds of powering on your computer, you will be at the Express Gate menu where you can start the web browser, Skype, or other Express Gate applications.

#### Notices about ASUS Express Gate

---



- Ensure to install ASUS Express Gate from the motherboard support DVD before use.
  - ASUS Express Gate supports SATA devices in IDE mode only. See chapter 3 for BIOS setup details.
  - ASUS Express Gate supports SATA devices connected to **motherboard chipset-controlled onboard SATA ports** only. All onboard extended SATA ports and external SATA ports are NOT supported. See chapter 2 for the exact location of onboard SATA ports.
  - ASUS Express Gate supports file uploading from ODD and USB drives and downloading to USB drives only.
  - ASUS Express Gate supports installation on SATA HDDs, USB HDDs and Flash drives with at least 1.2GB of available disk space. When installed on USB HDDs and Flash drives, connect the drives to the motherboard USB port before turning on the computer.
  - Your monitor must support the screen resolution of **1024 x 768**, or ASUS Express Gate will be skipped during the booting process, and the existing OS will be launched directly.
  - Installation of at least 1GB system memory is recommended for better performance.
-

## The First Screen

Express Gate's first screen appears within a few seconds after you power on the computer.

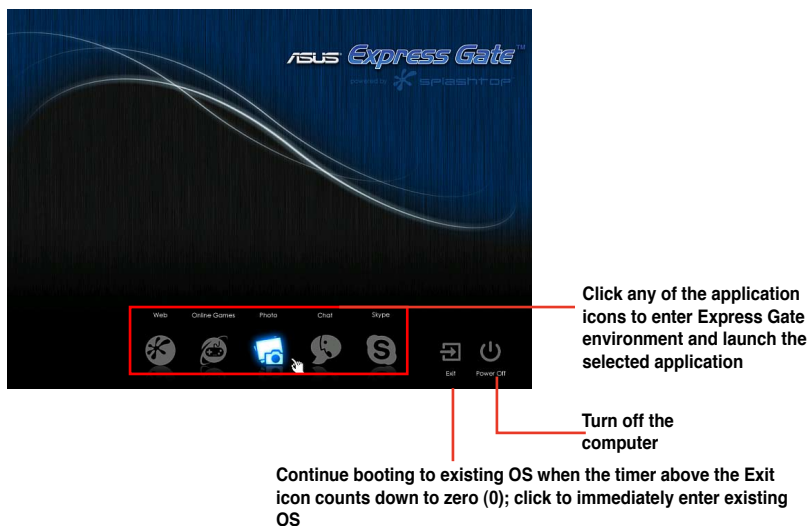

- To enter the motherboard BIOS setup program, click **Exit** on the Express Gate First Screen, and then press the <Del> key during POST.
- See the software manual in the bundled motherboard support DVD or click  in the Express Gate environment for detailed software instructions.
- Express Gate complies with the OpenGL standard. Refer to <http://support.asus.com> for Express Gate source codes.



### 4.3.6 ASUS T.Probe

The onboard T.Probe microchip detects and balances power phase loading and temperature in real-time. This feature optimizes the power phase functions, allowing components to run at lower temperatures and extending their lifespan. You can monitor the power phase loading and temperature in the Windows® environment with the bundled T.Probe application

#### Installing ASUS T.Probe

To install ASUS T.Probe on your computer

1. Place the support DVD to the optical drive. The **Drivers** installation tab appears if your computer has an enabled Autorun feature.
2. Click the **Utilities** tab, and then click **ASUS T.Probe**.
3. Follow the screen instructions to complete installation.

#### Before using ASUS T.Probe

You have to configure BIOS settings before using ASUS T.Probe.

1. Press <Del> during the Power-On Self Test (POST) to enter the Setup utility.
2. Set the **T.Probe** item in the **Advanced** menu to [Enabled]
3. Save BIOS settings and restart the computer.



Refer to Chapter 3 of the motherboard user manual for detailed instructions of BIOS settings

#### Using ASUS T.Probe

Click the T.Probe icon in the Windows® notification area to launch the T.Probe application.

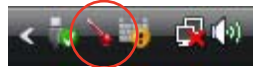

With T.Probe enabled, the temperature of the power phase gradually levels to the center AVG (average) area.



With T.Probe enabled, select “Power Saving Mode” on the top-right corner to switch to four phase mode. The temperature of the power phase gradually levels to the center AVG (average) area.



The number of the phase bars varies depending on motherboard model.

## 4.4 ASUS Unique Overclocking Utility—TurboV EVO

ASUS TurboV EVO introduces **TurboV** and **Turbo Key**—two powerful tools that allow you to overclock your system effectively. Install ASUS TurboV EVO from the support DVD that came with the motherboard package.

If the TurboV EVO is correctly installed, you will find the **TurboV EVO** icon on the Windows notification area. Click on the icon to display the TurboV EVO control panel.

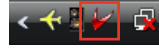

Refer to the software manual in the support DVD or visit the ASUS website at [www.asus.com](http://www.asus.com) for detailed software configuration.

### 4.4.1 Using ASUS TurboV

ASUS TurboV allows you to overclock the BCLK frequency, CPU voltage, IMC voltage, and DRAM Bus voltage in Windows® environment and takes effect in real-time without exiting and rebooting the OS.



Refer to the CPU documentation before adjusting CPU voltage settings. Setting a high voltage may damage the CPU permanently, and setting a low voltage may make the system unstable.



For system stability, all changes made in ASUS TurboV (except for **Auto Tuning**) will not be saved to BIOS settings and will not be kept on the next system boot. Use the **Save Profile** function to save your customized overclocking settings and manually load the profile after Windows starts.

The screenshot shows the ASUS TurboV EVO control panel. At the top, there are tabs for 'Easy Mode' and 'Auto Tuning Mode'. Below these are 'Manual Mode' and 'Turbo Key' options. The main area displays 'Profile' settings with a 'Save Profile' button. The settings are categorized into 'Start-up values' and 'Advanced CPU, chipset and DRAM voltage settings'. The 'Start-up values' section includes BCLK Frequency (133 MHz), CPU Voltage (1.08125 V), IMC Voltage (1.1 V), and DRAM Bus Voltage (1.5 V). The 'Advanced' section includes CPU PLL (1.8 V), PCH (1.05 V), CHA DATA (0.500 X), and CHB DATA (0.500 X). Annotations with red lines point to various elements: 'Manual Mode', 'Load profile', 'Target values', 'Start-up values', 'Advanced CPU, chipset and DRAM voltage settings', 'Save the current settings as a new profile', 'Voltage Adjustment bars', 'Click to show / hide more settings', 'Click to restore all start-up settings', and 'Undoes all changes without applying'.



- Set the **CPU Ratio Setting** item in BIOS to [Auto] before using the CPU Ratio function in TurboV. See Chapter 3 for details.
- For advanced overclock ability, adjust first the BIOS items, and then proceed more detailed adjustments using TurboV.

## 4.4.2 Using ASUS TurboV Auto Tuning Mode

The Auto Tuning Mode allows smart auto-overclocking. Follow the instructions below to let TurboV EVO detect and overclock your system.

1. Click the **Auto Tuning** tab and then click **Start**. You can also click **More Setting** first to configure more overclocking parameters before starting auto-overclocking.



2. Read through the warning messages and click **Yes** to start auto-overclocking.

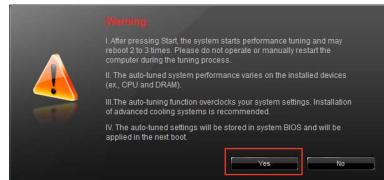

3. An animation appears indicating the overclocking process. Click **Stop** if you want to cancel the current Overclocking process.

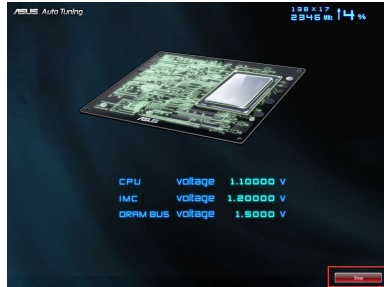

- After pressing Start, the system starts performance tuning and may reboot 2 to 3 times. Please do not operate or manually restart the computer during the tuning process.
- After restarting OS, a message appears indicating the current overclocking result. You can click **Stop** to save the current overclocking setting, or wait for TurboV EVO to continue system tuning for higher system performance.
- The auto-tuned system performance varies on the installed device (ex., CPU and DRAM).
- The auto-tuning function overclocks your system settings. Installation of advanced cooling systems is recommended.
- The auto-tuned settings will be stored in system BIOS and will be applied in the next boot.

## Using ASUS Turbo Key

ASUS Turbo Key allows the user to set a group of hot-keys into physical overclocking buttons. After the easy setup, Turbo Key can boost performances without interrupting ongoing work or games—with just one touch!

If the TurboV EVO is correctly installed, you will find the **TurboV EVO** icon on the Windows notification area. Click on the icon to display the TurboV EVO control panel. Click the **Turbo Key** tab to switch to the Turbo Key interface.



## Configuring ASUS Turbo Key



1. Select your desired hotkey combination.
2. You can decide the performance boost level by selecting **Turbo Key Profile**. You can also load personal profiles saved in the ASUS TurboV utility.
3. Choose whether to show Turbo Key OSD and status.
4. Click **Apply** to save Turbo Key settings.



---

You have to press the assigned hotkeys to use the Turbo Key function.

---

## 4.5 ASUS GPU Boost

ASUS GPU Boost allows you to overclock the integrated GPU voltage and integrated GPU frequency in Windows® environment and takes effect in real-time without exiting and rebooting the OS.



Refer to the CPU documentation before adjusting iGPU voltage settings. Setting a high voltage may damage the iGPU permanently, and setting a low voltage may make the system unstable.



- ASUS GPU Boost is available only when you install the GPU Boost driver from the motherboard support DVD.
- For system stability, all changes made in ASUS GPU Boost will not be saved to BIOS settings and will not be kept on the next system boot. Use the **Save Profile** function to save your customized overclocking settings and manually load the profile after Windows starts.
- EPU cannot run on the customized overclocking settings. Restart the computer to launch EPU.
- For system stability, set ASUS EPU to **High Performance Mode** while using ASUS GPU Boost.

### To launch ASUS GPU Boost

1. Install the ASUS TurboV utility from the motherboard support DVD.
2. Install the ASUS GPU Boost driver from the motherboard support DVD.
3. Click **start > All Programs > ASUS > TurboV > TurboV**.
4. Click **More Setting** from the TurboV main screen, and click the **GPU Boost** tab.

Adjustment sliders

Click the Easy Mode button to adjust iGPU frequency and iGPU voltage simultaneously

Undoes all changes without applying

Applies all changes immediately

Default settings    Target settings

## 4.6 RAID configurations

The motherboard comes with the Intel® 3450 chipset that allows you to configure Serial ATA hard disk drives as RAID sets. The motherboard supports the following RAID configurations: RAID 0, RAID 1, RAID 10 and RAID 5.



- You must install Windows® XP Service Pack 2 or later versions before using Serial ATA hard disk drives. The Serial ATA RAID feature is available only if you are using Windows® XP SP2 or later versions.
- Due to Windows® XP / Vista limitation, a RAID array with the total capacity over 2TB cannot be set as a boot disk. A RAID array over 2TB can only be set as a data disk only.
- If you want to install a Windows® operating system to a hard disk drive included in a RAID set, you have to create a RAID driver disk and load the RAID driver during OS installation. Refer to section **4.6 Creating a RAID driver disk** for details.

### 4.6.1 RAID definitions

**RAID 0 (Data striping)** optimizes two identical hard disk drives to read and write data in parallel, interleaved stacks. Two hard disks perform the same work as a single drive but at a sustained data transfer rate, double that of a single disk alone, thus improving data access and storage. Use of two new identical hard disk drives is required for this setup.

**RAID 1 (Data mirroring)** copies and maintains an identical image of data from one drive to a second drive. If one drive fails, the disk array management software directs all applications to the surviving drive as it contains a complete copy of the data in the other drive. This RAID configuration provides data protection and increases fault tolerance to the entire system. Use two new drives or use an existing drive and a new drive for this setup. The new drive must be of the same size or larger than the existing drive.

**RAID 5** stripes both data and parity information across three or more hard disk drives. Among the advantages of RAID 5 configuration include better HDD performance, fault tolerance, and higher storage capacity. The RAID 5 configuration is best suited for transaction processing, relational database applications, enterprise resource planning, and other business systems. Use a minimum of three identical hard disk drives for this setup.

**RAID 10** is data striping and data mirroring combined without parity (redundancy data) having to be calculated and written. With the RAID 10\* configuration you get all the benefits of both RAID 0 and RAID 1 configurations. Use four new hard disk drives or use an existing drive and three new drives for this setup.

**Intel® Matrix Storage.** The Intel® Matrix Storage technology supported by the 3450 chip allows you to create a RAID 0, RAID 1, RAID 5, and RAID 10\* function to improve both system performance and data safety. You can also combine two RAID sets to get higher performance, capacity, or fault tolerance provided by the difference RAID function. For example, RAID 0 and RAID 1 set can be created by using only two identical hard disk drives.

## 4.6.2 Installing Serial ATA hard disks

The motherboard supports Serial ATA hard disk drives. For optimal performance, install identical drives of the same model and capacity when creating a disk array.

To install the SATA hard disks for a RAID configuration:

1. Install the SATA hard disks into the drive bays.
2. Connect the SATA signal cables.
3. Connect a SATA power cable to the power connector on each drive.

## 4.6.3 Setting the RAID item in BIOS

You must enable the RAID function in the BIOS Setup before creating RAID set(s) using SATA HDDs. To do this:

1. Enter the BIOS Setup during POST.
2. Go to the **Main** menu > **Storage Configuration**, and then press <Enter>.
3. Set the **Configure SATA as** item to [RAID].
4. Save your changes, and then exit the BIOS Setup.



Refer to Chapter 3 for details on entering and navigating through the BIOS Setup.



Due to chipset limitation, when set any of SATA ports to RAID mode, all SATA ports run at RAID mode together.

## 4.6.4 Intel® Matrix Storage Manager option ROM utility

To enter the Intel® Matrix Storage Manager option ROM utility

1. Turn on the system.
2. During POST, press <Ctrl> + <I> to display the utility main menu.

```
Intel(R) Matrix Storage Manager option ROM v8.9.0.1014 PCH-D wRAIDS
Copyright(C) 2003-09 Intel Corporation. All Rights Reserved.

[ MAIN MENU ]
1. Create RAID Volume
2. Delete RAID Volume
3. Reset Disks to Non-RAID
4. Recovery Volume Options
5. Exit

[ DISK/VOLUME INFORMATION ]

RAID Volumes:
None defined.

Physical Disks:
Port Drive Model Serial # Size Type/Status (Vol ID)
0 ST3160812AS 9LS0BJA4 149.0GB Non-RAID Disk
1 ST3160812AS 9LS0F4HL 149.0GB Non-RAID Disk
2 ST3160812AS 3LS0JYL8 149.0GB Non-RAID Disk
3 ST3160812AS 9LS0BJ5H 149.0GB Non-RAID Disk

[↑↓]-Select [ESC]-Exit [ENTER]-Select Menu
```



The navigation keys at the bottom of the screen allow you to move through the menus and select the menu options.



The RAID BIOS setup screens shown in this section are for reference only and may not exactly match the items on your screen.



The utility supports maximum four hard disk drives for RAID configuration.

## Creating a RAID volume

To create a RAID set

1. From the utility main menu, select **1. Create RAID Volume** and press <Enter>. The following screen appears.

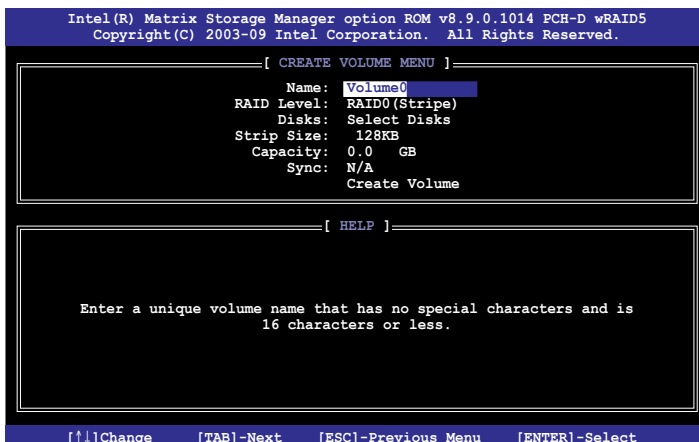

2. Enter a name for the RAID set and press <Enter>.
3. When the **RAID Level** item is selected, press the up/down arrow key to select a RAID mode to create, and then press <Enter>.
4. When the **Disks** item is selected, press <Enter> to select the hard disk drives you want to include in the RAID set. The **SELECT DISKS** screen appears.

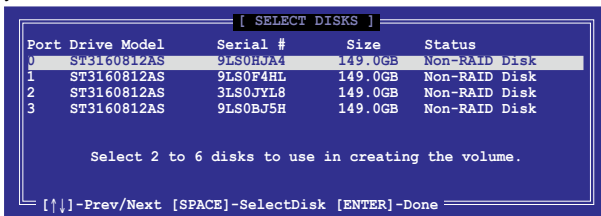

5. Use the up/down arrow key to select a drive, and then press <Space> to select. A small triangle marks the selected drive. Press <Enter> after completing your selection.
6. Use the up/down arrow key to select the stripe size for the RAID array (for RAID 0, 10 and 5 only), and then press <Enter>. The available stripe size values range from 4 KB to 128 KB. The following are typical values:  
RAID 0: 128KB  
RAID 10: 64KB  
RAID 5: 64KB



---

We recommend a lower stripe size for server systems, and a higher stripe size for multimedia computer systems used mainly for audio and video editing.

---

7. When the **Capacity** item is selected, enter the RAID volume capacity that you want and press <Enter>. The default value indicates the maximum allowed capacity.
8. When the **Create Volume** item is selected, press <Enter>. The following warning message appears.

```
WARNING: ALL DATA ON SELECTED DISKS WILL BE LOST.  
Are you sure you want to create this volume? (Y/N):
```

9. Press <Y> to create the RAID volume and return to the main menu, or <N> to go back to the **CREATE VOLUME** menu.

## Deleting a RAID set



Take caution when deleting a RAID set. You will lose all data on the hard disk drives when you delete a RAID set.

To delete a RAID set

1. From the utility main menu, select **2. Delete RAID Volume** and press <Enter>. The following screen appears.

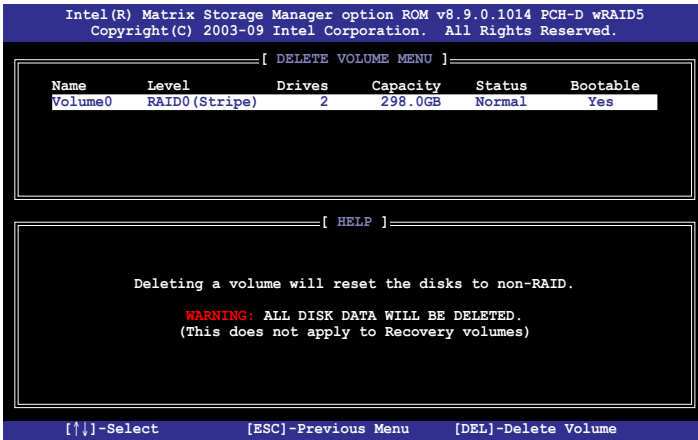

2. Use the up/down arrow key to select the RAID set you want to delete, and then press <Del>. The following warning message appears.

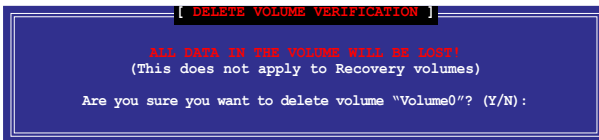

3. Press <Y> to delete the RAID set and return to the utility main menu, or press <N> to return to the **DELETE VOLUME** menu.

## Exiting the Intel® Matrix Storage Manager

To exit the utility

1. From the utility main menu, select **5. Exit**, and then press <Enter>. The following warning message appears.

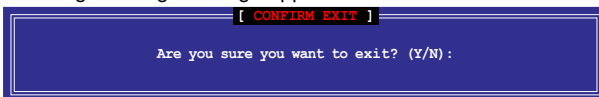

2. Press <Y> to exit or press <N> to return to the utility main menu.

## 4.7 Creating a RAID driver disk

A floppy disk with the RAID driver is required when installing Windows® XP operating system on a hard disk drive that is included in a RAID set. For Windows® Vista or later operating systems, use either a floppy disk or a USB flash drive with the RAID driver.



- **The motherboard does not provide a floppy drive connector.** You have to use a USB floppy disk drive when creating a SATA RAID driver disk.
- Windows® XP may not recognize the USB floppy disk drive due to Windows® XP limitation. To work around this OS limitation, refer to section **4.6.4 Using a USB floppy disk drive.**

### 4.7.1 Creating a RAID driver disk without entering the OS

To create a RAID driver disk without entering the OS

1. Boot your computer.
2. Press <Del> during POST to enter the BIOS setup utility.
3. Set the optical drive as the primary boot device.
4. Insert the support DVD into the optical drive.
5. Save changes and exit BIOS.
6. When the **Make Disk** menu appears, press <1> to create a 32/64bit **Intel AHCI/RAID driver disk.**
7. Insert a formatted floppy disk into the USB floppy disk drive, then press <Enter>.
8. Follow the succeeding screen instructions to complete the process.

### 4.7.2 Creating a RAID driver disk in Windows®

To create a RAID driver disk in Windows®:

1. Start Windows®.
2. Plug the USB floppy disk drive and insert a floppy disk.
3. Place the motherboard support DVD into the optical drive.
4. Go to the **Make Disk** menu, and then click **Intel AHCI/RAID Driver** to create an Intel® RAID driver disk.
5. Select USB floppy disk drive as the destination disk.
6. Follow the succeeding screen instructions to complete the process.



---

Write-protect the floppy disk to avoid a computer virus infection.

---

### 4.7.3 Installing the RAID driver during Windows® OS installation

To install the RAID driver for Windows® XP

1. During the OS installation, the system prompts you to press the F6 key to install third-party SCSI or RAID driver.
2. Press <F6>, and then insert the floppy disk with RAID driver into the USB floppy disk drive.
3. When prompted to select the SCSI adapter to install, ensure that you select **Intel(R) ICH8R/ICH9R/ICH10R/DO/PCH SATA RAID Controller**.
4. Follow the succeeding screen instructions to complete the installation.

To install the RAID driver for Windows® Vista or later OS

1. Insert the floppy disk or USB flash drive with RAID driver into the USB floppy disk drive or USB port.
2. During the OS installation, select **Intel(R) ICH8R/ICH9R/ICH10R/DO/PCH SATA RAID Controller**.
3. Follow the succeeding screen instructions to complete the installation.

### 4.7.4 Using a USB floppy disk drive

Due to OS limitation, Windows® XP may not recognize the USB floppy disk drive when you install the RAID driver from a floppy disk during the OS installation.

To solve this issue, add the USB floppy disk drive's Vendor ID (VID) and Product ID (PID) to the floppy disk containing the RAID driver. Refer to the steps below:

1. Using another computer, plug the USB floppy disk drive, and insert the floppy disk containing the RAID driver.

2. Right-click **My Computer** on the Windows® desktop or **start** menu, and then select **Manage** from the pop-up window.

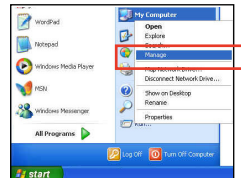
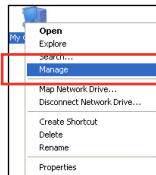

or

3. Select **Device Manager**. From the **Universal Serial Bus controllers**, right-click **xxxxxx USB Floppy**, and then select **Properties** from the pop-up window.

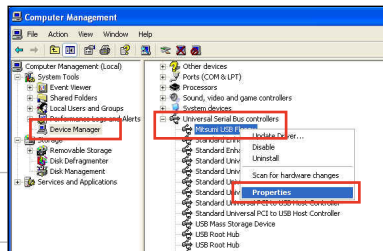

The name of the USB floppy disk drive varies with different vendors.

4. Click **Details** tab. The Vendor ID (VID) and Product ID (PID) are displayed.

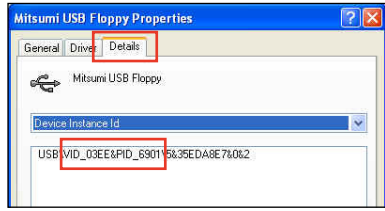

5. Browse the contents of the RAID driver disk to locate the file **txtsetup.oem**.
6. Double-click the file. A window appears, allowing you to select the program for opening the oem file.

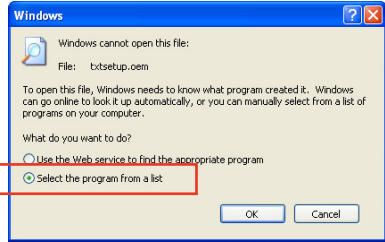

7. Use Notepad to open the file.

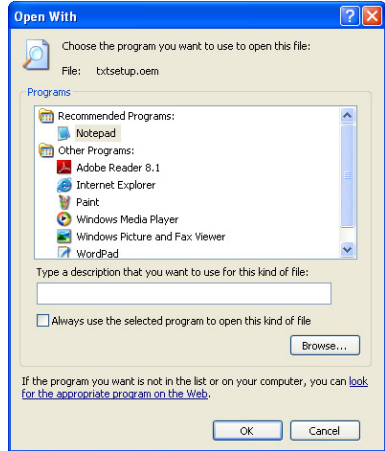

- Find the **[HardwareIds.scsi.iaAHCI\_PCH]** and **[HardwareIds.scsi.iaStor\_8R9R10RDOPCH]** sections in the **txtsetup.oem** file.
- Type the following line to the bottom of the two sections:  
**id = "USB\VID\_03EE&PID\_6901", "usbstor"**

```
[HardwareIds.scsi.iaAHCI_PCH]
id= "PCI\VEN_8086&DEV_3A22&CC_0106", "iaStor"
id= "USB\VID_03EE&PID_6901", "usbstor"

[HardwareIds.scsi.iaStor_8R9R10RDOPCH]
id= "PCI\VEN_8086&DEV_3A22&CC_0106", "iaStor"
id= "USB\VID_03EE&PID_6901", "usbstor"
```



Add the same line to both sections.



The VID and PID vary with different vendors.

- Save and exit the file.





This chapter describes how to install and configure multiple ATI® CrossFireX™ and NVIDIA® SLI™ graphics cards.

# 5 Multiple GPU technology support

5.1 ATI® CrossFireX™ technology ..... 5-1

5.2 NVIDIA® SLI™ technology ..... 5-5

5.3 NVIDIA® CUDA™ technology ..... 5-11

## 5.1 ATI® CrossFireX™ technology

The motherboard supports the ATI® CrossFireX™ technology that allows you to install multi-graphics processing units (GPU) graphics cards. Follow the installation procedures in this section.

### 5.1.1 Requirements

- In CrossFireX mode, you should have two identical CrossFireX-ready graphics cards or one CrossFireX-ready dual-GPU graphics card that are ATI® certified.
- Ensure that your graphics card driver supports the ATI CrossFireX technology. Download the latest driver from the AMD website ([www.amd.com](http://www.amd.com)).
- Ensure that your power supply unit (PSU) can provide at least the minimum power required by your system. See page 2-43 for details.



- 
- We recommend that you install additional chassis fans for better thermal environment.
  - Visit the ATI Game website at <http://game.amd.com> for the latest certified graphics card and the supported 3D application list.
- 

### 5.1.2 Before you begin

For ATI CrossFireX to work properly, you have to uninstall all existing graphics card drivers before installing ATI CrossFireX graphics cards to your system.

To uninstall existing graphics card drivers

1. Close all current applications.
2. For Windows XP, go to **Control Panel > Add/Remove Programs**.  
For Windows Vista, go to **Control Panel > Programs and Features**.
3. Select your current graphics card driver/s.
4. For Windows XP, select **Add/Remove**.  
For Windows Vista, select **Uninstall**.
5. Turn off your computer.

### 5.1.3 Installing CrossFireX graphics cards



The following pictures are for reference only. The graphics cards and the motherboard layout may vary with models, but the installation steps remain the same.

1. Prepare two CrossFireX-ready graphics cards.
2. Insert the two graphics card into the PCIEX16 slots. If your motherboard has more than two PCIEX16 slots, refer to Chapter 2 in this user manual for the locations of the PCIEX16 slots recommended for multi-graphics card installation.

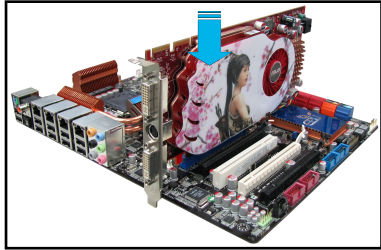

3. Ensure that the cards are properly seated on the slots.
4. Align and firmly insert the CrossFireX bridge connector to the goldfingers on each graphics card. Ensure that the connector is firmly in place.

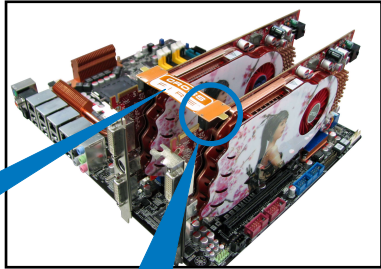

CrossFireX bridge

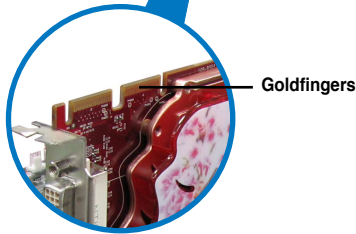

Goldfingers

5. Connect two independent auxiliary power sources from the power supply to the two graphics cards separately.
6. Connect a VGA or a DVI cable to the graphics card.

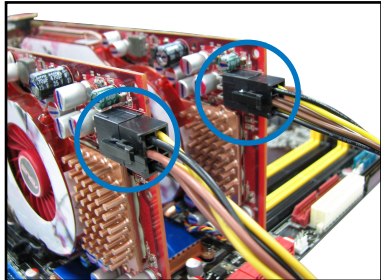

## 5.1.4 Installing the device drivers

Refer to the documentation that came with your graphics card package to install the device drivers.



Ensure that your PCI Express graphics card driver supports the ATI® CrossFireX™ technology. Download the latest driver from the AMD website at [www.amd.com](http://www.amd.com).

## 5.1.5 Enabling the ATI® CrossFireX™ technology

After installing your graphics cards and the device drivers, enable the CrossFireX™ feature through the ATI Catalyst™ Control Center in Windows environment.

### Launching the ATI Catalyst Control Center

To launch the ATI Catalyst Control Center

1. Right-click on the Windows® desktop and select **Catalyst(TM) Control Center**. You can also right-click the ATI icon in the Windows notification area and select **Catalyst Control Center**.

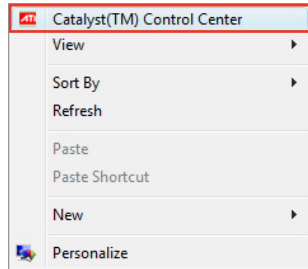

2. The **Catalyst Control Center Setup Assistant** appears when the system detects the existence of multi-graphics cards. Click **Go** to continue to the **Catalyst Control Center Advanced View** window.

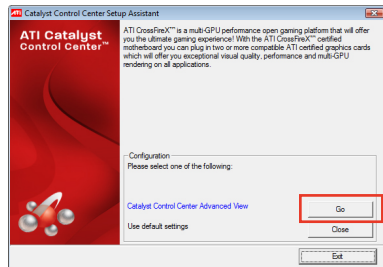

## Enabling Dual CrossFireX settings

1. In the Catalyst Control Center window, click **Graphics Settings > CrossFireX > Configure**.
2. From the Graphics Adapter list, select the graphics card to act as the display GPU.
3. Select **Enable CrossFireX**.
4. Click **Apply**, and then click **OK** to exit the window.

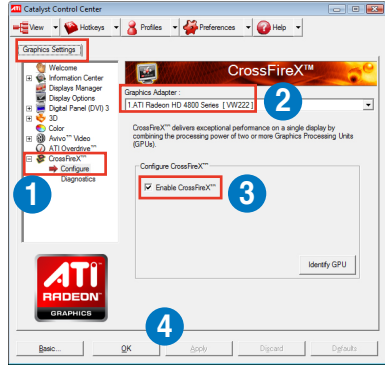

## 5.2 NVIDIA® SLI™ technology

The motherboard supports the NVIDIA® SLI™ (Scalable Link Interface) technology that allows you to install multi-graphics processing units (GPU) graphics cards. Follow the installation procedures in this section.

### 5.2.1 Requirements

- In Dual SLI mode, you should have two identical SLI-ready graphics cards that are NVIDIA® certified.
- In Triple SLI mode, you should have three identical SLI-ready graphics cards that are NVIDIA® certified.
- Ensure that your graphics card driver supports the NVIDIA SLI technology. Download the latest driver from the NVIDIA website ([www.nvidia.com](http://www.nvidia.com)).
- Ensure that your power supply unit (PSU) can provide at least the minimum power required by your system. See page 2-43 for details.



- 
- We recommend that you install additional chassis fans for better thermal environment.
  - The NVIDIA Triple SLI technology is supported by Windows® Vista™ operating system only.
  - Visit the NVIDIA zone website at <http://www.nzone.com> for the latest certified graphics card and supported 3D application list.
-

## 5.2.2 Installing two SLI-ready graphics cards



The following pictures are for reference only. The graphics cards and the motherboard layout may vary with models, but the installation steps remain the same.

1. Prepare two SLI-ready graphics cards.
2. Insert the two graphics card into the PCIEX16 slots. If your motherboard has more than two PCIEX16 slots, refer to Chapter 2 in this user manual for the locations of the PCIEX16 slots recommended for multi-graphics card installation.
3. Ensure that the cards are properly seated on the slots.
4. Align and firmly insert the SLI bridge connector to the goldfingers on each graphics card. Ensure that the connector is firmly in place.
5. Connect two independent auxiliary power sources from the power supply to the two graphics cards separately.
6. Connect a VGA or a DVI cable to the graphics card.

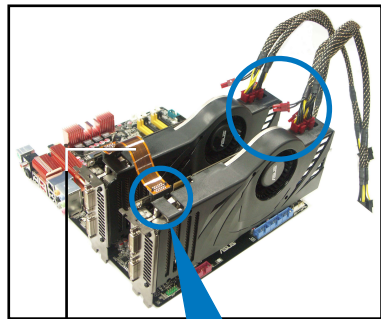
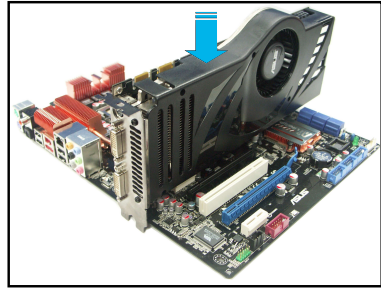

SLI bridge

Goldfingers

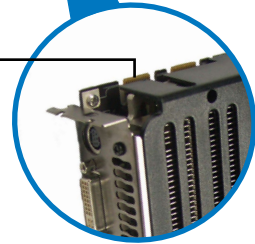



## 5.2.3 Installing three SLI-ready graphics cards

1. Prepare three SLI-ready graphics cards.
2. Insert the three graphics card into the PCIEX16 slots. If your motherboard has more than two PCIEX16 slots, refer to Chapter 2 in this user manual for the locations of the PCIEX16 slots recommended for multi-graphics card installation.
3. Ensure that the cards are properly seated on the slots.
4. Align and firmly insert the 3-Way SLI bridge connector to the goldfingers on each graphics card. Ensure that the connector is firmly in place.
5. Connect three independent auxiliary power sources from the power supply to the three graphics cards separately.
6. Connect a VGA or a DVI cable to the graphics card.

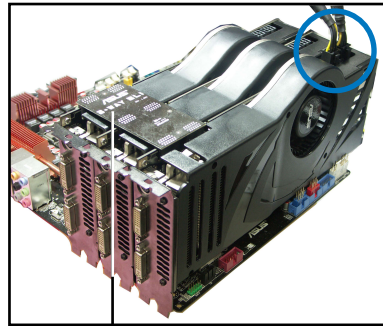
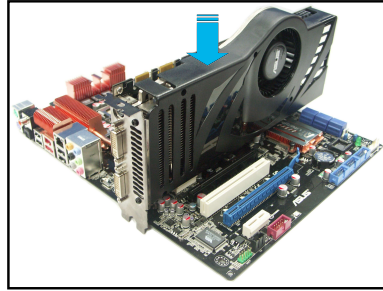

3-Way SLI bridge

## 5.2.4 Installing the device drivers

Refer to the documentation that came with your graphics card package to install the device drivers.



- Ensure that your PCI Express graphics card driver supports the NVIDIA® SLI™ technology. Download the latest driver from the NVIDIA website at [www.nvidia.com](http://www.nvidia.com).
- If you are using a Triple SLI system, ensure to install the NVIDIA® 3-way SLI driver under Windows® Vista™. The NVIDIA 3-way SLI technology is supported by Windows® Vista™ only.

## 5.2.5 Enabling the NVIDIA® SLI™ technology

After installing your graphics cards and the device drivers, enable the SLI feature in NVIDIA® Control Panel under the Windows® Vista™ operating system.

### Launching the NVIDIA Control Panel

You can launch the NVIDIA Control Panel by the following two methods.

- A. Right click on the empty space of the Windows® desktop and select **NVIDIA Control Panel**.

The NVIDIA Control Panel window appears (See Step B5 on page 5-10).

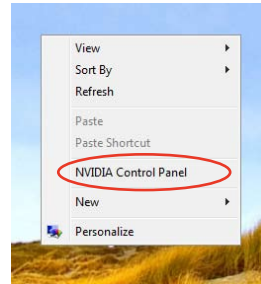

- B1. If you cannot see the NVIDIA Control Panel item in step (A), select **Personalize**.

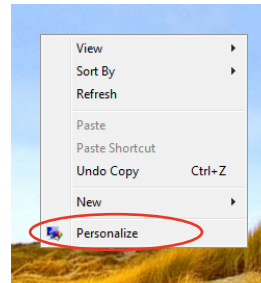

- B2. From the **Personalization** window, select **Display Settings**.

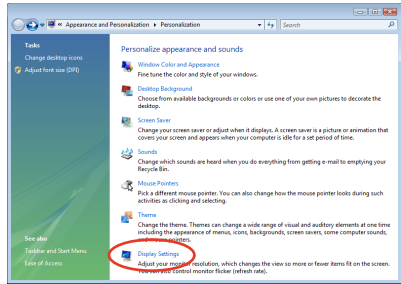

- B3. From the Display Settings dialog box, click **Advanced Settings**.

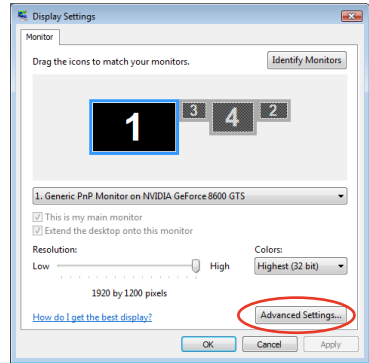

- B4. Select the **NVIDIA GeForce** tab, and then click **Start the NVIDIA Control Panel**.

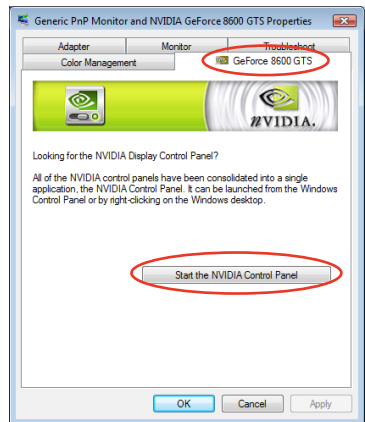

B5. The NVIDIA Control Panel window appears.

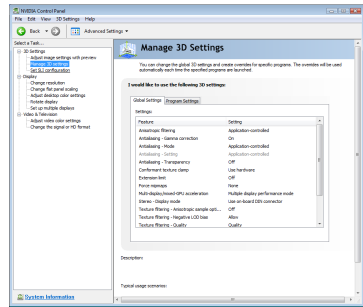

### Enabling Dual SLI settings

From the NVIDIA Control Panel window, select **Set SLI Configuration**. Click **Enable SLI** and set the display for viewing SLI rendered content. When done, click **Apply**.

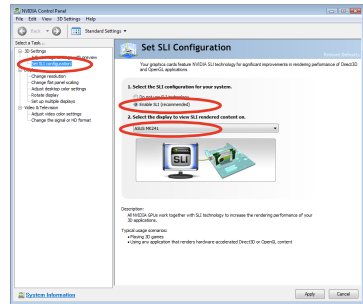

### Enabling Triple SLI settings

1. From the NVIDIA Control Panel window, select **Set SLI Configuration**, and then click **Enable 3-way NVIDIA SLI**. When done, click **Apply**.

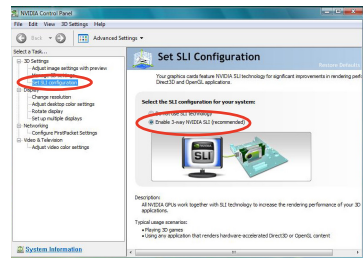

2. Select the **3D Settings** tab and enable the **Show SLI Visual Indicators** item. When this item is enabled, a green bar appears on the left side of the screen while 3D demonstrations are rendered, indicating the 3-way SLI status.

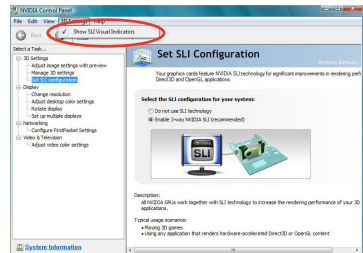

## 5.3 NVIDIA® CUDA™ technology

The motherboard supports the NVIDIA® CUDA™ technology with one NVIDIA® Quadro™ graphics card and up to three NVIDIA® Tesla™ computing processor cards, providing the optimum multi purpose computing performance. Follow the installation procedures in this section.



The motherboard supports 4 NVIDIA Tesla cards when you install Clarkdale processor.

### 5.3.1 Requirements

- 32/64-bit Microsoft® Windows XP/ Vista/ Linux RHEL5.3/ Open SuSE11.0 OS
- A minimum of 1GB RAM
- A power supply unit (PSU) of 1200W is recommended while using one NVIDIA® Quadro™ graphics card and three NVIDIA® Tesla™ computing processor cards.



- We recommend that you install additional chassis fans for better thermal environment.
- Visit the NVIDIA CUDA Zone website at [http://www.nvidia.com/object/cuda\\_home.html](http://www.nvidia.com/object/cuda_home.html) for the latest driver, list of CUDA-certified graphics card and supported 3D application list.

### 5.3.2 Installing CUDA-ready graphics cards



The following pictures are for reference only. The graphics cards and the motherboard layout may vary with models, but the installation steps remain the same.

1. Prepare one NVIDIA Quadro graphics card and up to three NVIDIA Tesla computing processor cards.
2. Insert the Quadro graphics card into the PCIe x16\_1 slot. Ensure that the card is properly seated on the slot.

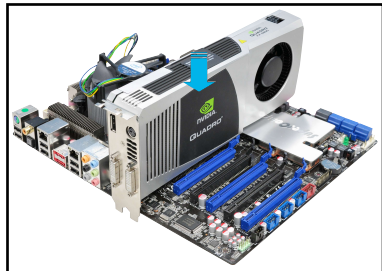

- 3. Insert the Tesla computing processor card(s) into the PCIe x16\_2, PCIe x16\_3 or PCIe x16\_4 slot. Ensure that the cards are properly seated on the slot.

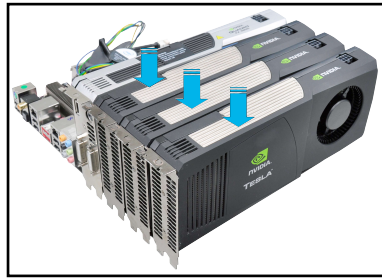

- 4. Connect either one 8-pin power connector or two 6-pin power connectors from the power supply to the Quadro graphics card and Tesla computing processor card(s).
- 5. Connect a display cable to the graphics card.

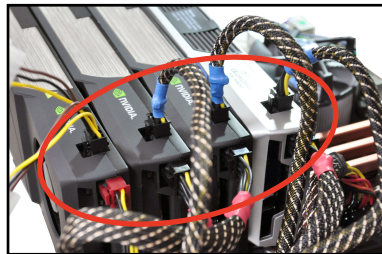

- 6. Refer to the documentation that came with your graphics card package to install the device drivers.
- 7. To verify graphics card driver installation, right-click **My Computer** and select **Properties** from the menu. Click the **Hardware** tab, and then click **Device Manager**. Click the “+” sign before **Display adapters**, and the installed graphics card and computing processor card(s) should appear.

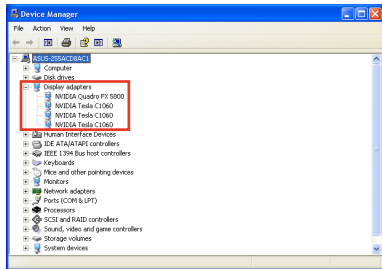

The screen differs based on the components you installed.