

**Rampage III  
Black Edition**



**Motherboard**

E6488

Second Edition

March 2011

**Copyright © 2011 ASUSTeK COMPUTER INC. All Rights Reserved.**

No part of this manual, including the products and software described in it, may be reproduced, transmitted, transcribed, stored in a retrieval system, or translated into any language in any form or by any means, except documentation kept by the purchaser for backup purposes, without the express written permission of ASUSTeK COMPUTER INC. ("ASUS").

Product warranty or service will not be extended if: (1) the product is repaired, modified or altered, unless such repair, modification or alteration is authorized in writing by ASUS; or (2) the serial number of the product is defaced or missing.

ASUS PROVIDES THIS MANUAL "AS IS" WITHOUT WARRANTY OF ANY KIND, EITHER EXPRESS OR IMPLIED, INCLUDING BUT NOT LIMITED TO THE IMPLIED WARRANTIES OR CONDITIONS OF MERCHANTABILITY OR FITNESS FOR A PARTICULAR PURPOSE. IN NO EVENT SHALL ASUS, ITS DIRECTORS, OFFICERS, EMPLOYEES OR AGENTS BE LIABLE FOR ANY INDIRECT, SPECIAL, INCIDENTAL, OR CONSEQUENTIAL DAMAGES (INCLUDING DAMAGES FOR LOSS OF PROFITS, LOSS OF BUSINESS, LOSS OF USE OR DATA, INTERRUPTION OF BUSINESS AND THE LIKE), EVEN IF ASUS HAS BEEN ADVISED OF THE POSSIBILITY OF SUCH DAMAGES ARISING FROM ANY DEFECT OR ERROR IN THIS MANUAL OR PRODUCT.

SPECIFICATIONS AND INFORMATION CONTAINED IN THIS MANUAL ARE FURNISHED FOR INFORMATIONAL USE ONLY, AND ARE SUBJECT TO CHANGE AT ANY TIME WITHOUT NOTICE, AND SHOULD NOT BE CONSTRUED AS A COMMITMENT BY ASUS. ASUS ASSUMES NO RESPONSIBILITY OR LIABILITY FOR ANY ERRORS OR INACCURACIES THAT MAY APPEAR IN THIS MANUAL, INCLUDING THE PRODUCTS AND SOFTWARE DESCRIBED IN IT.

Products and corporate names appearing in this manual may or may not be registered trademarks or copyrights of their respective companies, and are used only for identification or explanation and to the owners' benefit, without intent to infringe.

# Contents

Notices.....	ix
Safety information .....	xiii
About this guide .....	xv
Rampage III Black Edition specifications summary.....	xvii
<b>Chapter 1: Product introduction</b>	
1.1 Welcome!.....	1-1
1.2 Package contents.....	1-1
1.3 Special features.....	1-2
1.3.1 Product highlights .....	1-2
1.3.2 ROG ThunderBolt LAN/Audio Combo.....	1-3
1.3.3 ROG Intelligent Performance & Overclocking features...	1-4
1.3.4 ASUS special features .....	1-7
<b>Chapter 2: Hardware information</b>	
2.1 Before you proceed .....	2-1
2.2 Motherboard overview.....	2-2
2.2.1 Motherboard layout.....	2-2
2.2.2 Layout contents.....	2-3
2.2.3 Central Processing Unit (CPU) .....	2-4
2.2.4 System memory .....	2-5
2.2.5 Expansion slots.....	2-16
2.2.6 Onboard switches .....	2-19
2.2.7 Onboard LEDs .....	2-22
2.2.8 Jumper .....	2-31
2.2.9 Internal connectors .....	2-33
2.3 Building your computer system .....	2-42
2.3.1 Additional tools and components to build a PC system	2-42
2.3.2 CPU installation .....	2-43
2.3.3 CPU heatsink and fan assembly installation.....	2-45
2.3.4 DIMM installation .....	2-47
2.3.5 Motherboard installation.....	2-48
2.3.6 ATX Power connection.....	2-50
2.3.7 SATA device connection.....	2-51
2.3.8 Front I/O Connector .....	2-52

# Contents

2.3.9	Expansion Card installation .....	2-53
2.3.10	ThunderBolt .....	2-54
2.3.11	Rear panel connection .....	2-56
2.3.12	Audio I/O connections.....	2-57
<b>2.4</b>	<b>Starting up for the first time.....</b>	<b>2-60</b>
<b>2.5</b>	<b>Turning off the computer.....</b>	<b>2-61</b>
2.5.1	Using the OS shut down function.....	2-61
2.5.2	Using the dual function power switch.....	2-61
 <b>Chapter 3: BIOS Setup</b>		
<b>3.1</b>	<b>Managing and updating your BIOS .....</b>	<b>3-1</b>
3.1.1	ASUS Update utility .....	3-1
3.1.2	ASUS EZ Flash 2 utility.....	3-5
3.1.3	ASUS CrashFree BIOS 3 utility .....	3-6
<b>3.2</b>	<b>BIOS Setup program.....</b>	<b>3-7</b>
3.2.1	BIOS menu screen.....	3-8
3.2.2	Menu bar.....	3-8
3.2.3	Navigation keys.....	3-8
3.2.4	Menu items .....	3-9
3.2.5	Submenu items .....	3-9
3.2.6	Configuration fields .....	3-9
3.2.7	Pop-up window .....	3-9
3.2.8	Scroll bar.....	3-9
3.2.9	General help .....	3-9
<b>3.3</b>	<b>Extreme Tweaker menu .....</b>	<b>3-10</b>
3.3.1	GPU.DIMM Post .....	3-11
3.3.2	CPU Level Up [Auto].....	3-11
3.3.3	Ai Overclock Tuner [Auto] .....	3-11
3.3.4	CPU Ratio Setting [Auto] .....	3-11
3.3.5	CPU Turbo Power Limit [Disabled] .....	3-11
3.3.6	CPU Configuration .....	3-12
3.3.7	BCLK Frequency [XXX] .....	3-12
3.3.8	BCLK Enhance [Auto].....	3-12
3.3.9	PCIe Frequency [XXX] .....	3-12
3.3.10	DRAM Frequency [Auto].....	3-12

# Contents

3.3.11	UCLK Frequency [Auto] .....	3-12
3.3.12	QPI Link Data Rate [Auto].....	3-12
3.3.13	Memory Recheck [Disabled] .....	3-12
3.3.14	Memory Configuration Protect [Disabled] .....	3-13
3.3.15	DRAM Timing Control .....	3-13
3.3.16	CPU QPI Strength [Auto] .....	3-13
3.3.17	ALT QPI Strength [Auto].....	3-13
3.3.18	First 2 Slots PCIE Strength [Auto].....	3-13
3.3.19	Last 2 Slots PCIE Strength [Auto].....	3-13
3.3.20	CPU Differential Amplitude [Auto] .....	3-13
3.3.21	CPU Clock Skew [Auto] .....	3-13
3.3.22	IOH Clock Skew [Auto] .....	3-13
3.3.23	Digi+ VRM Duty Control [T.Probe] .....	3-14
3.3.24	PWM Volt. Control [Auto] .....	3-14
3.3.25	Load-Line Calibration [Auto] .....	3-14
3.3.26	CPU Voltage OCP [Enabled].....	3-14
3.3.27	CPU PWM Frequency [Auto] .....	3-14
3.3.28	Phase Control [Extreme].....	3-14
3.3.29	Extreme OV [Disabled] .....	3-14
3.3.30	Extreme OC [Auto].....	3-14
3.3.31	CPU Voltage [Auto] .....	3-14
3.3.32	CPU PLL Voltage [Auto].....	3-14
3.3.33	QPI/DRAM Core Voltage [Auto] .....	3-15
3.3.34	DRAM Bus Voltage [Auto].....	3-15
3.3.35	DRAM REF Voltages .....	3-15
3.3.36	IOH Voltage [Auto] .....	3-15
3.3.37	IOH PCIE Voltage [Auto].....	3-15
3.3.38	ICH Voltage [Auto] .....	3-15
3.3.39	ICH PCIE Voltage [Auto].....	3-15
3.3.40	ASUS O.C. Profile.....	3-15
3.3.41	CPU Spread Spectrum [Auto] .....	3-16
3.3.42	PCIE Spread Spectrum [Auto] .....	3-16
<b>3.4</b>	<b>Main menu .....</b>	<b>3-17</b>
3.4.1	System Time [xx:xx:xx] .....	3-17

# Contents

3.4.2	System Date [Day xx/xx/xxxx].....	3-17
3.4.3	Language [English] .....	3-17
3.4.4	SATA 1–6.....	3-18
3.4.5	Storage Configuration.....	3-20
3.4.6	AHCI Configuration.....	3-21
3.4.7	System Information.....	3-22
<b>3.5</b>	<b>Advanced menu .....</b>	<b>3-23</b>
3.5.1	CPU Configuration.....	3-23
3.5.2	Chipset.....	3-26
3.5.3	Onboard Devices Configuration.....	3-27
3.5.4	USB Configuration .....	3-29
3.5.5	PCI PnP.....	3-30
3.5.6	LED Control .....	3-31
3.5.7	iROG Configuration.....	3-32
3.5.8	ROG Connect .....	3-33
<b>3.6</b>	<b>Power menu.....</b>	<b>3-34</b>
3.6.1	Suspend Mode [Auto] .....	3-34
3.6.2	Repost Video on S3 Resume [No].....	3-34
3.6.3	ACPI 2.0 Support [Disabled].....	3-34
3.6.4	ACPI APIC Support [Enabled].....	3-35
3.6.5	EuP Ready [Disabled].....	3-35
3.6.6	APM Configuration.....	3-35
3.6.7	Hardware Monitor .....	3-37
<b>3.7</b>	<b>Boot menu .....</b>	<b>3-40</b>
3.7.1	Boot Device Priority .....	3-40
3.7.2	Boot Settings Configuration .....	3-41
3.7.3	Security.....	3-42
<b>3.8</b>	<b>Tools menu .....</b>	<b>3-44</b>
3.8.1	ASUS EZ Flash 2.....	3-44
3.8.2	ASUS O.C. Profile.....	3-45
3.8.3	GO Button File .....	3-47
3.8.4	BIOS FlashBack.....	3-48
<b>3.9</b>	<b>Exit menu .....</b>	<b>3-49</b>

# Contents

<b>Chapter 4:</b>	<b>Software support</b>	
<b>4.1</b>	<b>Installing an operating system</b>	<b>4-1</b>
<b>4.2</b>	<b>Support DVD information</b>	<b>4-1</b>
4.2.1	Running the support DVD	4-1
4.2.2	Obtaining the software manuals	4-2
<b>4.3</b>	<b>Software information</b>	<b>4-3</b>
4.3.1	AI Suite II	4-3
4.3.2	DIGI+ VRM	4-4
4.3.3	TurboV EVO	4-7
4.3.4	EPU	4-9
4.3.5	FAN Xpert	4-10
4.3.6	Probe II	4-11
4.3.7	ROG Connect	4-12
4.3.8	ThunderBolt LAN--Bigfoot Killer Network Manager	4-15
4.3.9	ThunderBolt Audio	4-18
4.3.10	ROG Wi-Fi Agent	4-22
4.3.11	Audio configurations	4-25
<b>4.4</b>	<b>RAID configurations</b>	<b>4-27</b>
4.4.1	RAID definitions	4-27
4.4.2	Installing Serial ATA hard disks	4-28
4.4.3	Setting the RAID item in BIOS	4-28
4.4.4	Intel® Rapid Storage Technology Option ROM utility	4-29
<b>4.5</b>	<b>Creating a RAID driver disk</b>	<b>4-33</b>
4.5.1	Creating a RAID driver disk without entering the OS	4-33
4.5.2	Creating a RAID driver disk in Windows®	4-33
4.5.3	Installing the RAID driver during Windows® OS installation	4-34
4.5.4	Using a USB floppy disk drive	4-35
<b>Chapter 5:</b>	<b>ATI® CrossFireX™ technology support</b>	
<b>5.1</b>	<b>ATI® CrossFireX™ technology</b>	<b>5-1</b>
5.1.1	Requirements	5-1
5.1.2	Before you begin	5-1
5.1.3	Installing CrossFireX graphics cards	5-2
5.1.4	Installing the device drivers	5-3

# Contents

5.1.5	Enabling the ATI® CrossFireX™ technology .....	5-3
<b>5.2</b>	<b>NVIDIA® SLI™ technology .....</b>	<b>5-5</b>
5.2.1	Requirements.....	5-5
5.2.2	Installing two SLI-ready graphics cards .....	5-5
5.2.3	Installing the device drivers.....	5-6
5.2.4	Enabling the NVIDIA® SLI™ technology .....	5-6



# Notices

## Federal Communications Commission Statement

This device complies with Part 15 of the FCC Rules. Operation is subject to the following two conditions:

- This device may not cause harmful interference, and
- This device must accept any interference received including interference that may cause undesired operation.

This equipment has been tested and found to comply with the limits for a Class B digital device, pursuant to Part 15 of the FCC Rules. These limits are designed to provide reasonable protection against harmful interference in a residential installation. This equipment generates, uses and can radiate radio frequency energy and, if not installed and used in accordance with manufacturer's instructions, may cause harmful interference to radio communications. However, there is no guarantee that interference will not occur in a particular installation. If this equipment does cause harmful interference to radio or television reception, which can be determined by turning the equipment off and on, the user is encouraged to try to correct the interference by one or more of the following measures:

- Reorient or relocate the receiving antenna.
- Increase the separation between the equipment and receiver.
- Connect the equipment to an outlet on a circuit different from that to which the receiver is connected.
- Consult the dealer or an experienced radio/TV technician for help.



The use of shielded cables for connection of the monitor to the graphics card is required to assure compliance with FCC regulations. Changes or modifications to this unit not expressly approved by the party responsible for compliance could void the user's authority to operate this equipment.

---

## FCC Radio Frequency (RF) Exposure Caution Statement



Any changes or modifications not expressly approved by the party responsible for compliance could void the user's authority to operate this equipment. "The manufacture declares that this device is limited to Channels 1 through 11 in the 2.4GHz frequency by specified firmware controlled in the USA."

---

This equipment complies with FCC radiation exposure limits set forth for an uncontrolled environment. To maintain compliance with FCC RF exposure compliance requirements, please avoid direct contact to the transmitting antenna during transmitting. End users must follow the specific operating instructions for satisfying RF exposure compliance.

## **RF exposure warning**

This equipment must be installed and operated in accordance with provided instructions and the antenna(s) used for this transmitter must be installed to provide a separation distance of at least 20 cm from all persons and must not be co-located or operating in conjunction with any other antenna or transmitter. End-users and installers must be provide with antenna installation instructions and transmitter operating conditions for satisfying RF exposure compliance.

## **Declaration of Conformity (R&TTE directive 1999/5/EC)**

The following items were completed and are considered relevant and sufficient:

- Essential requirements as in [Article 3]
- Protection requirements for health and safety as in [Article 3.1a]
- Testing for electric safety according to [EN 60950]
- Protection requirements for electromagnetic compatibility in [Article 3.1b]
- Testing for electromagnetic compatibility in [EN 301 489-1] & [EN 301 489-17]
- Effective use of the radio spectrum as in [Article 3.2]
- Radio test suites according to [EN 300 328-2]

## **CE Marking**



### **CE marking for devices without wireless LAN/Bluetooth**

The shipped version of this device complies with the requirements of the EEC directives 2004/108/EC “Electromagnetic compatibility” and 2006/95/EC “Low voltage directive”.



### **CE marking for devices with wireless LAN/ Bluetooth**

This equipment complies with the requirements of Directive 1999/5/EC of the European Parliament and Commission from 9 March, 1999 governing Radio and Telecommunications Equipment and mutual recognition of conformity.

## Wireless Operation Channel for Different Domains

N. America	2.412-2.462 GHz	Ch01 through CH11
Japan	2.412-2.484 GHz	Ch01 through Ch14
Europe ETSI	2.412-2.472 GHz	Ch01 through Ch13

## France Restricted Wireless Frequency Bands

Some areas of France have a restricted frequency band. The worst case maximum authorized power indoors are:

- 10mW for the entire 2.4 GHz band (2400 MHz–2483.5 MHz)
- 100mW for frequencies between 2446.5 MHz and 2483.5 MHz



---

Channels 10 through 13 inclusive operate in the band 2446.6 MHz to 2483.5 MHz.

---

There are few possibilities for outdoor use: On private property or on the private property of public persons, use is subject to a preliminary authorization procedure by the Ministry of Defense, with maximum authorized power of 100mW in the 2446.5–2483.5 MHz band. Use outdoors on public property is not permitted.

In the departments listed below, for the entire 2.4 GHz band:

- Maximum authorized power indoors is 100mW
- Maximum authorized power outdoors is 10mW

Departments in which the use of the 2400–2483.5 MHz band is permitted with an EIRP of less than 100mW indoors and less than 10mW outdoors:

01 Ain	02 Aisne	03 Allier	05 Hautes Alpes
08 Ardennes	09 Ariège	11 Aude	12 Aveyron
16 Charente	24 Dordogne	25 Doubs	26 Drôme
32 Gers	36 Indre	37 Indre et Loire	41 Loir et Cher
45 Loiret	50 Manche	55 Meuse	58 Nièvre
59 Nord	60 Oise	61 Orne	63 Puy du Dôme
64 Pyrénées Atlantique		66 Pyrénées Orientales	
67 Bas Rhin	68 Haut Rhin	70 Haute Saône	71 Saône et Loire
75 Paris	82 Tarn et Garonne		84 Vaucluse
88 Vosges	89 Yonne	90 Territoire de Belfort	
94 Val de Marne			

This requirement is likely to change over time, allowing you to use your wireless LAN card in more areas within France. Please check with ART for the latest information ([www.arcep.fr](http://www.arcep.fr))



---

Your WLAN Card transmits less than 100mW, but more than 10mW.

---

## Canadian Department of Communications Statement

This digital apparatus does not exceed the Class B limits for radio noise emissions from digital apparatus set out in the Radio Interference Regulations of the Canadian Department of Communications.

This class B digital apparatus complies with Canadian ICES-003.

Cet appareil numérique de la classe [B] est conforme à la norme NMB-003 du Canada.

## IC Radiation Exposure Statement for Canada

This equipment complies with IC radiation exposure limits set forth for an uncontrolled environment. To maintain compliance with IC RF exposure compliance requirements, please avoid direct contact to the transmitting antenna during transmitting. End users must follow the specific operating instructions for satisfying RF exposure compliance.

Operation is subject to the following two conditions:

- This device may not cause interference and
- This device must accept any interference, including interference that may cause undesired operation of the device.

To prevent radio interference to the licensed service (i.e. co-channel Mobile Satellite systems) this device is intended to be operated indoors and away from windows to provide maximum shielding. Equipment (or its transmit antenna) that is installed outdoors is subject to licensing.



The user is cautioned that this device should be used only as specified within this manual to meet RF exposure requirements. Use of this device in a manner inconsistent with this manual could lead to excessive RF exposure conditions.

---

This device and its antenna(s) must not be co-located or operating in conjunction with any other antenna or transmitter.

Country Code selection feature to be disabled for products marketed to the US/ CANADA.

# Safety information

## Electrical safety

- To prevent electrical shock hazard, disconnect the power cable from the electrical outlet before relocating the system.
- When adding or removing devices to or from the system, ensure that the power cables for the devices are unplugged before the signal cables are connected. If possible, disconnect all power cables from the existing system before you add a device.
- Before connecting or removing signal cables from the motherboard, ensure that all power cables are unplugged.
- Seek professional assistance before using an adapter or extension cord. These devices could interrupt the grounding circuit.
- Ensure that your power supply is set to the correct voltage in your area. If you are not sure about the voltage of the electrical outlet you are using, contact your local power company.
- If the power supply is broken, do not try to fix it by yourself. Contact a qualified service technician or your retailer.
- The optical S/PDIF is an optional component (may or may not be included in your motherboard) and is defined as a CLASS 1 LASER PRODUCT.



---

INVISIBLE LASER RADIATION, AVOID EXPOSURE TO BEAM.

---

- Never dispose of the battery in fire. It could explode and release harmful substances into the environment.
- Never dispose of the battery with your regular household waste. Take it to a hazardous material collection point.
- Never replace the battery with an incorrect battery type.



- 
- RISK OF EXPLOSION IF BATTERY IS REPLACED BY AN INCORRECT TYPE.
  - DISPOSE OF USED BATTERIES ACCORDING TO THE ABOVE BATTERY-RELATED INSTRUCTIONS.
-

## Operation safety

- Before installing the motherboard and adding devices on it, carefully read all the manuals that came with the package.
- Before using the product, ensure all cables are correctly connected and the power cables are not damaged. If you detect any damage, contact your dealer immediately.
- To avoid short circuits, keep paper clips, screws, and staples away from connectors, slots, sockets and circuitry.
- Avoid dust, humidity, and temperature extremes. Do not place the product in any area where it may become wet.



---

This motherboard should only be used in environments with ambient temperatures between 5°C (41°F) and 40°C (104°F).

---

- Place the product on a stable surface.
- If you encounter technical problems with the product, contact a qualified service technician or your retailer.

## REACH

Complying with the REACH (Registration, Evaluation, Authorisation, and Restriction of Chemicals) regulatory framework, we published the chemical substances in our products at ASUS REACH website at <http://csr.asus.com/english/REACH.htm>.

## ASUS Recycling/Takeback Services

ASUS recycling and takeback programs come from our commitment to the highest standards for protecting our environment. We believe in providing solutions for you to be able to responsibly recycle our products, batteries, other components as well as the packaging materials. Please go to <http://csr.asus.com/english/Takeback.htm> for detailed recycling information in different regions.



---

**DO NOT** throw the motherboard in municipal waste. This product has been designed to enable proper reuse of parts and recycling. This symbol of the crossed out wheeled bin indicates that the product (electrical and electronic equipment) should not be placed in municipal waste. Check local regulations for disposal of electronic products.

---



---

**DO NOT** throw the mercury-containing button cell battery in municipal waste. This symbol of the crossed out wheeled bin indicates that the battery should not be placed in municipal waste.

---

# About this guide

This user guide contains the information you need when installing and configuring the motherboard.

## How this guide is organized

This guide contains the following parts:

- **Chapter 1: Product introduction**  
This chapter describes the features of the motherboard and the new technology it supports.
- **Chapter 2: Hardware information**  
This chapter lists the hardware setup procedures that you have to perform when installing system components. It includes description of the switches, jumpers, and connectors on the motherboard.
- **Chapter 3: BIOS setup**  
This chapter tells how to change system settings through the BIOS Setup menus. Detailed descriptions of the BIOS parameters are also provided.
- **Chapter 4: Software support**  
This chapter describes the contents of the support DVD that comes with the motherboard package and the software.
- **Chapter 5: Multiple GPU technology support**  
This chapter describes how to install and configure multiple ATI® CrossFireX™ and NVIDIA® SLI™ graphics cards.

## Where to find more information

Refer to the following sources for additional information and for product and software updates.

1. **ASUS websites**  
The ASUS website provides updated information on ASUS hardware and software products. Refer to the ASUS contact information.
2. **Optional documentation**  
Your product package may include optional documentation, such as warranty flyers, that may have been added by your dealer. These documents are not part of the standard package.

## Conventions used in this guide

To ensure that you perform certain tasks properly, take note of the following symbols used throughout this manual.



**DANGER/WARNING:** Information to prevent injury to yourself when trying to complete a task.



**CAUTION:** Information to prevent damage to the components when trying to complete a task.



**IMPORTANT:** Instructions that you **MUST** follow to complete a task.



**NOTE:** Tips and additional information to help you complete a task.

## Typography

### **Bold text**

Indicates a menu or an item to select.

### *Italics*

Used to emphasize a word or a phrase.

### <Key>

Keys enclosed in the less-than and greater-than sign means that you must press the enclosed key.

Example: <Enter> means that you must press the Enter or Return key.

### <Key1+Key2+Key3>

If you must press two or more keys simultaneously, the key names are linked with a plus sign (+).

Example: <Ctrl+Alt+D>

### **Command**

Means that you must type the command exactly as shown, then supply the required item or value enclosed in brackets.

Example: At the DOS prompt, type the command line:

```
afudos /iR3BE.ROM
```



# Rampage III Black Edition specifications summary

<b>CPU</b>	LGA1366 socket for Intel® Core™i7 Processor Extreme Edition / Core™i7 Processor Support Intel® Turbo Boost Technology * Refer to <a href="http://www.asus.com">www.asus.com</a> for Intel CPU support list
<b>Chipset</b>	Intel® X58/ICH10R
<b>System Bus</b>	Up to 6.4 GT/s with QuickPath Interconnection
<b>Memory</b>	Triple channel memory architecture 6 x DIMM, max. 48GB, DDR3 2200(O.C.)/ 2133(O.C.)/ 2000(O.C.)/ 1800(O.C.)/ 1600/ 1333/ 1066 MHz, non-ECC, un-buffered memory modules Supports Intel® Extreme Memory Profile (XMP) * Hyper DIMM support is subject to the physical characteristics of individual CPUs. Some hyper DIMMs only support one DIMM per channel. Please refer to <a href="http://www.asus.com">www.asus.com</a> or this user manual for the Memory QVL (Qualified Vendors Lists) for details.
<b>Expansion Slots</b>	4 x PCIe2.0 x16 slots, support x16; x16/x16; x16/x8/x8 and x8/x8/x8/x8 configurations 2 x PCIe x1
<b>Multi-GPU Technology</b>	Support NVIDIA 3-Way SLI™ / ATI CrossFireX™ Technology 4 PCIe x16 slots ready for 4 single PCB 2-slot width graphics cards
<b>Storage</b>	<b>ICH10R Southbridge:</b> <ul style="list-style-type: none"> <li>- 6 x SATA 3.0 Gb/s ports</li> <li>- Intel® Rapid Storage Technology supports RAID 0, 1, 5 and 10</li> </ul> <b>JMicron® 363 controller:</b> <ul style="list-style-type: none"> <li>- 2 x External SATA 3.0 Gb/s port</li> </ul> <b>Marvell® 9182 PCIe SATA 6Gb/s controller</b> <ul style="list-style-type: none"> <li>- 2 x SATA 6.0 Gb/s ports</li> </ul>
<b>LAN</b>	Gigabit Intel® Ethernet LAN
<b>High Definition Audio</b>	SupremeFX X-Fi 2 Built-in 8-Channel High Definition Audio CODEC <ul style="list-style-type: none"> <li>- EAX® Advanced™ HD 5.0</li> <li>- THX TruStudio PRO™</li> <li>- X-Fi Xtreme Fidelity™</li> <li>- Creative ALchemy</li> <li>- Blu-ray audio layer content protection</li> <li>- Supports Jack-detection, Multi-streaming, Front Panel Jack-retasking</li> </ul>

*(continued on the next page)*

# Rampage III Black Edition specifications summary

<p><b>ThunderBolt LAN/Audio Combo Card</b></p>	<p><b>Dedicated network processing unit (NPU)</b></p> <ul style="list-style-type: none"> <li>- Advanced Game Detect™</li> <li>- Visual Bandwidth Control™</li> <li>- Application Blocking</li> <li>- Online Gaming PC Monitor™</li> <li>- Bandwidth Tester</li> <li>- Game Networking DNA™</li> </ul> <p><b>Built-in 2-Channel High Quality DAC/ ADC</b></p> <ul style="list-style-type: none"> <li>- Output Signal-to-Noise Ratio (A-Weighted): 116 dB</li> <li>- Output THD+N at 1kHz: 105 dB</li> <li>- C-Media 6631 audio processor (Max. 192kHz/24-bit)</li> <li>- TI 6120A2 high fidelity headphone amplifier</li> <li>- Digital-to-Analog Converter: 120 dB (Max. 192kHz/24-bit)</li> <li>- Analog-to-Digital Converter: 114 dB (Max. 192kHz/24-bit)</li> <li>- Supports 3 Headphone Impedance Gain Modes (up to 300 Ohms)</li> <li>- Fine-tuned Game Genre EQ Profiles</li> <li>- Xear™ Surround Headphone</li> <li>- Xear™ SingFX</li> <li>- Equalizer, Environment Effects, FlexBass, Smart Volume, Virtual Speaker Shifter</li> <li>- DS3D GX 1.0, OpenAL</li> <li>- Front-panel audio connector (AAFP)</li> <li>- Line in, Line out, Optical S/PDIF out ports</li> <li>- USB 2.0 Interface</li> </ul>
<p><b>Bluetooth</b></p>	<p>IEEE 802.11b/g/n, Wi-Fi Compliant, Bluetooth v3.0 + HS</p>
<p><b>USB</b></p>	<p><b>NEC® USB 3.0 controller</b></p> <ul style="list-style-type: none"> <li>- 4 x USB 3.0/2.0 ports (2 at back panel; 2 at midboard)</li> </ul> <p><b>Intel® ICH10R Southbridge</b></p> <ul style="list-style-type: none"> <li>- 11 x USB 2.0/1.1 ports (4 ports at midboard; 6 ports at back panel, 1 reserved for ROG Connect)</li> </ul>
<p><b>ROG Exclusive Overclocking Features</b></p>	<p><b>ROG Connect</b></p> <ul style="list-style-type: none"> <li>- RC Poster</li> <li>- RC Remote</li> <li>- RC Diagram</li> <li>- GPU TweakIt</li> </ul> <p>ROG iDirect GPU.DIMM Post</p> <p><b>ROG Extreme Engine Digi+</b></p> <ul style="list-style-type: none"> <li>- 8-phase CPU power</li> <li>- 3-phase QPI/DRAM power</li> <li>- 3-phase NB power</li> <li>- 3-phase Memory power</li> <li>- ML Caps on CPU, Memory and QPI respectively</li> </ul>

# Rampage III Black Edition specifications summary

<b>ROG Exclusive Overclocking Features</b>	Probelit iROG Extreme Tweaker BIOS Flashback with onboard switch button Loadline Calibration <b>ROG Extreme OC kit</b> <ul style="list-style-type: none"> <li>- LN2 Mode</li> <li>- PCIe x16 Lane Switch</li> <li>- Q_Reset</li> <li>- Double Power Supply with dual 8-pin (CPU) power connectors</li> </ul> <b>Intelligent overclocking tools:</b> <ul style="list-style-type: none"> <li>- ASUS AI Booster Utility</li> <li>- O.C Profile</li> </ul> <b>Overclocking Protection:</b> <ul style="list-style-type: none"> <li>- COP EX (Component Overheat Protection - EX)</li> <li>- Voltiminder LED</li> <li>- ASUS C.P.R.(CPU Parameter Recall)</li> </ul>
<b>Other Special Features</b>	CPU Level Up MemOK! Onboard Switches: Power / Reset / Clr CMOS (at rear) ASUS MyLogo3 ASUS Fan Xpert ASUS EZ Flash 2 ASUS CrashFree BIOS 3 Q-Fan Plus ROG BIOS Wallpaper ASUS EPU Engine ASUS Q-Connector ASUS Q-LED (CPU, DRAM, VGA, Boot Device LED) ASUS Q-Slot ASUS Q-DIMM
<b>Back Panel I/O Ports</b>	1 x PS/2 Keyboard port 2 x Wi-Fi antenna jacks 1 x Clr CMOS switch 2 x External SATA ports 1 x LAN (RJ45) port 1 x ROG Connect On/Off switch 2 x USB 3.0/2.0 ports (Blue) 7 x USB 2.0/1.1 ports (1 port also for ROG Connect) 8-channel Audio I/O
<b>Manageability</b>	WOL by PME, WOR by PME, PXE
<b>BIOS Features</b>	16Mb AMI BIOS, PnP, DMI2.0, WfM2.0, SM BIOS 2.5, ACPI2.0a Multi-Language BIOS

(continued on the next page)

# Rampage III Black Edition specifications summary

<b>Internal I/O Connectors</b>	<ul style="list-style-type: none"> <li>1 x USB 3.0 connector supports additional 2 USB 3.0 ports</li> <li>2 x USB 2.0 connectors support additional 4 USB 2.0 ports</li> <li>8 x SATA connectors: 2 x SATA 6G connectors (Grey); 6 x standard SATA connectors (Black)</li> <li>8 x Fan connectors: 2 x CPU / 3 x Chassis / 3 x Optional</li> <li>8 x Probelit Measurement Points</li> <li>3 x Thermal sensor connectors</li> <li>1 x QPI Loadline calibration switch jumper (QPI_LL_SW)</li> <li>1 x SPDIF_Out Connector</li> <li>1 x 24-pin ATX Power connector</li> <li>2 x 8-pin ATX 12V Power connectors</li> <li>1 x En/Dis-able Cir CMOS header</li> <li>1 x LN2 Mode Header</li> <li>1 x START (Power On) button</li> <li>1 x RESET button</li> <li>1 x EZ Plug connector (4-pin Molex Power connector)</li> <li>1 x Go Button</li> <li>1 x BIOS Switch button</li> <li>1 x ROG light connector</li> <li>1 x Audio front panel (AAFP)</li> <li>1 x System panel connector</li> </ul>
<b>Software</b>	<p><b>Support DVD:</b></p> <ul style="list-style-type: none"> <li>- Drivers and Applications</li> <li>Kaspersky Anti-Virus</li> <li>ASUS TurboV EVO Utility</li> <li>ASUS PC Probe II</li> <li>ASUS Update</li> <li>ASUS AI Suite II</li> <li>Ai Charger</li> <li>Wi-Fi Agent</li> </ul>
<b>Form Factor</b>	extended ATX Form Factor, 12"x 10.6" (30.5cm x 26.9cm)

\*Specifications are subject to change without notice.

This chapter describes the motherboard features and the new technologies it supports.

# 1 Product introduction

# Chapter summary



1.1	Welcome! .....	1-1
1.2	Package contents.....	1-1
1.3	Special features.....	1-2

## 1.1 Welcome!

Thank you for buying an ROG Rampage III Black Edition motherboard!

The motherboard delivers a host of new features and latest technologies, making it another standout in the long line of ASUS quality motherboards!

Before you start installing the motherboard, and hardware devices on it, check the items in your package with the list below.

## 1.2 Package contents

Check your motherboard package for the following items.

Motherboard	ROG Rampage III Black Edition
Cables	1 x ROG Connect cable 1 x USB to USB cable for ThunderBolt 1 x CrossFire Cable 1 x SLI Cable 3 x 2-in-1 SATA 3Gb/s signal cables 1 x 2-in-1 SATA 6Gb/s signal cables
Accessories	1 x 2 in 1 ASUS Q-Connector Kit 1 x 2-port USB 2.0 + ESATA module 1 x 3-Way SLI bridge 1 x I/O Shield 3 x Thermal Sensor Cable Packs 1 x Cable Ties Pack 1 x ROG Theme Label 1 x 12-in-1 ROG Cable Label 2 x Wi-Fi Ring Moving Antenna 1 x Optional NB Fan
Application DVD	ROG motherboard support DVD
Documentation	User guide ROG ThunderBolt Audio Precision Test Report



If any of the above items is damaged or missing, contact your retailer.

## 1.3 Special features

### 1.3.1 Product highlights

#### Republic of Gamers



The Republic of Gamers consists only the best of the best. We offer the best hardware engineering, the fastest performance, the most innovating ideas, and we welcome the best gamers to join in. In the Republic of Gamers, mercy rules are only for the weak, and bragging rights means everything. We believe in making statements and we excel in competitions. If your character matches our trait, then join the elite club, make your presence felt, in the Republic of Gamers.

#### Green ASUS



This motherboard and its packaging comply with the European Union's Restriction on the use of Hazardous Substances (RoHS). This is in line with the ASUS vision of creating environment-friendly and recyclable products/packaging to safeguard consumers' health while minimizing the impact on the environment.

#### LGA1366 Intel® Core™ i7 Ready



This motherboard supports the latest Intel® Core™ i7 processors in LGA1366 package with integrated memory controller to support 3-channel (6 DIMMs) DDR3 memory. Supports Intel® QuickPath Interconnect (QPI) with a system bus of up to 6.4 GT/s and a max bandwidth of up to 25.6 GB/s. Intel® Core™ i7 processor is one of the most powerful and energy efficient CPUs in the world.

#### Intel® X58 Chipset



The Intel® X58 Express Chipset is one of the most powerful chipset designed to support the Intel® Core™ i7 Processors with LGA1366 package and Intel® next generation system interconnect interface, Intel® QuickPath Interconnect (QPI), providing improved performance by utilizing serial point-to-point links, allowing increased bandwidth and stability. It also supports up to 36 PCI Express 2.0 lanes providing better graphics performance.

#### Tri-Channel, DDR3 2200(O.C.) MHz



The motherboard supports DDR3 memory that features data transfer rates of 2200(O.C.)/2133(O.C.)/2000(O.C.)/1800(O.C.)/1600(O.C.)/1333/1066 MHz to meet the higher bandwidth requirements of the latest operation system, 3D graphics, multimedia, and Internet applications. The dual-channel DDR3 architecture double the bandwidth of your system memory to boost system performance.



## PCIe 2.0

### Double Speed; Double Bandwidth

This motherboard supports the latest PCIe 2.0 devices for double speed and bandwidth which enhances system performance.

## SLI/CrossFireX On-Demand

### Why choose when you can have both?

SLI or CrossFireX? Fret no longer because with the ROG Rampage III Black Edition, you'll be able to run both multi-GPU setups. The board features SLI/ CrossFireX on Demand technology, supporting SLI or CrossFireX configuration. Whichever path you take, you can be assured of jaw-dropping graphics at a level previously unseen.

## True USB 3.0 Support

### 10X Faster Data Rates!

Experience ultra-fast data transfers at 4.8Gbps with USB 3.0—the latest connectivity standard. Built to connect easily with next generation components and peripherals, USB 3.0 transfers data 10X faster and is also backward compatible with USB 2.0 components.

## SATA 6Gb/s Support

### Experience the Future of Storage!

Supporting next-generation Serial ATA (SATA) storage interface, this motherboard delivers up to 6.0Gb/s data transfer rates. Additionally, get enhanced scalability, faster data retrieval, double the bandwidth of current bus systems.

## 1.3.2 ROG ThunderBolt LAN/Audio Combo

### Built-in Headphone Amp.

### Sound GREATER

The ROG ThunderBolt is a dedicated LAN/audio combo card designed for gamers. With the ROG ThunderBolt's high sound quality and built-in amp, gamers can discover the enemy's position much easier and react earlier, making it just like another weapon in a gamer's arsenal! With fine-tuned background sound effects for popular game types and Xear 3D Surround tech, ROG ThunderBolt lets you hear better and win easier!

## **Dedicated NPU**



### **Play FASTER**

Even with a high-end CPU and GPU, FPS and MMORPGs can still become a laggy mess if the LAN performance sucks. Gamers yearn to keep gaming framerates solid. The ROG ThunderBolt has been designed from continual feedback from the PC gaming community. By enhancing the 2 key factors (Speed and Sound) that dominate your gaming experience, the advanced integration of the LAN/Audio combo ThunderBolt offers higher throughput and decreased latency is about to bring the best in-game experience to you!

Note: Network Processing Unit (NPU)

## **1.3.3 ROG Intelligent Performance & Overclocking features**

### **GPU.DIMM Post**



#### **Easily check the status of your graphics cards and memory in the BIOS!**

Notice potential problems even before you enter the OS! Overclockers can save valuable minutes in detecting component failure under extreme conditions. With GPU.DIMM Post, quickly and easily check your graphics cards and memory DIMMs status in the BIOS, potentially keeping that record-breaking overclock!

### **ROG iDirect**



#### **Tune our PC from your iPhone or iPad now!**

Still overclock your PC the old-fashioned way? Let ROG iDirect bring you a whole new tweaking experience right on your iPhone or iPad! Thanks to the Bluetooth support that comes with select ASUS ROG motherboards, you can monitor your PC and tweak parameters such voltages and frequencies in real time wirelessly from your iPhone or iPad!

### **Extreme Engine Digi+**



#### **Powerful combination of analog and digital design elements**

Extreme Engine Digi+ equipped with high performance digital VRM design can easily achieve the ultimate performance with adjustable CPU PWM frequency. It expedites heat dissipation and achieves better electric conduction keeping critical components reliable. Now you'll be able to push your spanking new Intel CPU to the limit, hitting benchmark scores that others only dream of. Extreme Engine Digi+ balances the need for voltage and the desire for rock solid performance to bring the ultimate user experience.

## **ROG Connect**



### **Plug and Overclock - Tweak it the hardcore way!**

Monitor the status of your desktop PC and tweak its parameters in real-time via a notebook—just like a race car engineer—with ROG Connect. ROG Connect links your main system to a notebook through a USB cable, allowing you to view real-time POST code and hardware status readouts on your notebook, as well as make on-the-fly parameter adjustments at a purely hardware level. Diagram, power, reset button, flash BIOS through notebook.

## **Bluetooth v3.0 + HS**



### **Diverse Bluetooth and Wi-Fi Enjoyment, New Technology Lifestyle**

Onboard Bluetooth v3.0 + HS enables smart connectivity to Bluetooth and wireless internet devices with no additional adapters. Enjoy the convenience and faster transfer rates of Wi-Fi anywhere on both desktops and notebooks.

The Bluetooth® word mark and logos are registered trademarks owned by Bluetooth SIG, Inc. and any use of such marks by ASUSTeK Computer Inc. is under license. Other trademarks and trade names are those of their respective owners.

## **Probelt**



### **Get all hands-on with hardware-based overclocking**

Probelt takes the guesswork out of locating the motherboard's measurement points, identifying them clearly in the form of 8 sets of detection points so you'll know exactly where to get quick yet accurate readings using a multimeter.

## **iROG**



### **Intelligent multiple control at hand**

The iROG is a special IC which enables several ROG highlighted functions that gives users full disposal of the motherboard at any stage! This design allows advanced user control and management to be processed purely at a hardware level. iROG greatly increases fun during overclocking for PC enthusiasts and it offers system maintenance and management with more control and efficiency.

## BIOS Flashback

**Two BIOS ROM. Two BIOS settings. Twice the overclocking flexibility.**

Overclocker's prayer to have BIOS flexibility is answered! With the new BIOS Flashback, PC enthusiasts can overclock with even more confidence. BIOS Flashback gives overclockers the ability to save two versions of the BIOS simultaneously. Very much like the "SaveGame" function, one BIOS can be used for the overclocking adventure, while the other BIOS is to be stored with any previous version. BIOS Flashback brings the ultimate convenience to overclockers! By pushing BIOS button, overclockers can easily choose which BIOS ROM they want to save & boot from.

## CPU Level Up

**A simple click for instant upgrade!**

Ever wish that you could have a more expansive CPU? Upgrade your CPU at no additional cost with ROG's CPU Level Up! Simply pick the processor you wanted to OC to, and the motherboard will do the rest! See the new CPU speed and enjoy that performance instantly. Overclocking is never as easy as this.

## Extreme Tweaker

**One stop performance tuning shop**

Extreme Tweakers is the one stop shop to fine-tune your system to optimal performance. No matter if you're looking for frequency adjustment, over-voltage options, or memory timing settings, they're all here!

## Voltiminder LED

**Friendly reminder on Voltage Settings**

In the pursuit of extreme performance, overvoltage adjustment is critical but risky. Acting as the "red zone" of a tachometer, the Voltiminder LED displays the voltage status for CPU, PCH, and Memory in a intuitive color-coded fashion. The voltiminder LED allows quick voltage monitoring for overclockers.

## COP EX

**Maximum OC with confidence with burn proof protection to chipsets and GPU!**

The COP EX allows overclockers to increase chipset voltage without the worries of overheating. It can also be used to monitor and save an overheating GPU. The COP EX allows more freedom and less constraint for maximum performance achievement.

## Loadline Calibration

### Optimal power boost for extreme CPU overclocking!

Maintaining ample voltage support for the CPU is critical during overclocking. The Loadline Calibration ensures stable and optimal CPU voltage under heavy loading. It helps overclockers enjoy the motherboard's ultimate OC capabilities and benchmark scores.

## 1.3.4 ASUS special features

### SupremeFX X-Fi 2 Built-in



#### Play with ultra-real cinematic in-game surround sound!

SupremeFX X-Fi 2 delivers incredible gaming audio experiences to ROG die hards. It features EAX 5.0 and OpenAL for ultra-real cinematic in-game audio. It even comes with THX TruStudio Pro, which makes games, music and movies sound way better! SupremeFX X-Fi 2 also implements gold-plated jacks and high quality capacitors to ensure high definition adventures in audio.

### 8-channel Audio

#### Enjoy high-end sound system on your PC!

The onboard 8-channel HD audio (High Definition Audio, previously codenamed Azalia) CODEC enables high-quality 192KHz/24-bit audio output, jack-sensing feature, retasking functions and multi-streaming technology.

### Onboard Switches

#### No more shorting pins or moving jumpers

With an easy press during overclock, this exclusive onboard switch allows gamer to effortlessly fine-tune the performance without having to short the pins or moving jumpers!

### Q-Fan Plus

#### Optimized quietness and cooling for more devices

The Q-Fan function automatically detects temperature and adjusts fan speed accordingly to achieve quiet and efficient cooling. With Q-Fan Plus, special temperature sensor cable is provided to detect temperature on any device. When used with optional fans, you may activate Q-Fan function on up to 3 additional devices of your choice!

## **ASUS Q-Connector**



### **Make connections quick and accurate**

The Q-Connector allows you to connect or disconnect chassis front panel cables in one easy step with one complete module. This unique adapter eliminates the trouble of plugging in one cable at a time, making connection quick and accurate.

## **Kaspersky® Anti-Virus**



### **The best protection from viruses and spyware**

Kaspersky® Anti-Virus Personal offers premium antivirus protection for individual users and home offices. It is based on advanced antivirus technologies. The product incorporates the Kaspersky® Anti-Virus engine, which is renowned for malicious program detection rates that are among the industry's highest.

This chapter lists the hardware setup procedures that you have to perform when installing system components. It includes description of the jumpers and connectors on the motherboard.

# Hardware 2 information

2.1	Before you proceed .....	2-1
2.2	Motherboard overview.....	2-2
2.3	Building your computer system .....	2-42
2.4	Starting up for the first time.....	2-60
2.5	Turning off the computer.....	2-61



## 2.1 Before you proceed

Take note of the following precautions before you install motherboard components or change any motherboard settings.



- 
- Unplug the power cord from the wall socket before touching any component.
  - Before handling components, use a grounded wrist strap or touch a safely grounded object or a metal object, such as the power supply case, to avoid damaging them due to static electricity.
  - Hold components by the edges to avoid touching the ICs on them.
  - Whenever you uninstall any component, place it on a grounded antistatic pad or in the bag that came with the component.
  - Before you install or remove any component, ensure that the ATX power supply is switched off or the power cord is detached from the power supply. Failure to do so may cause severe damage to the motherboard, peripherals, or components.
-

## 2.2 Motherboard overview

### 2.2.1 Motherboard layout

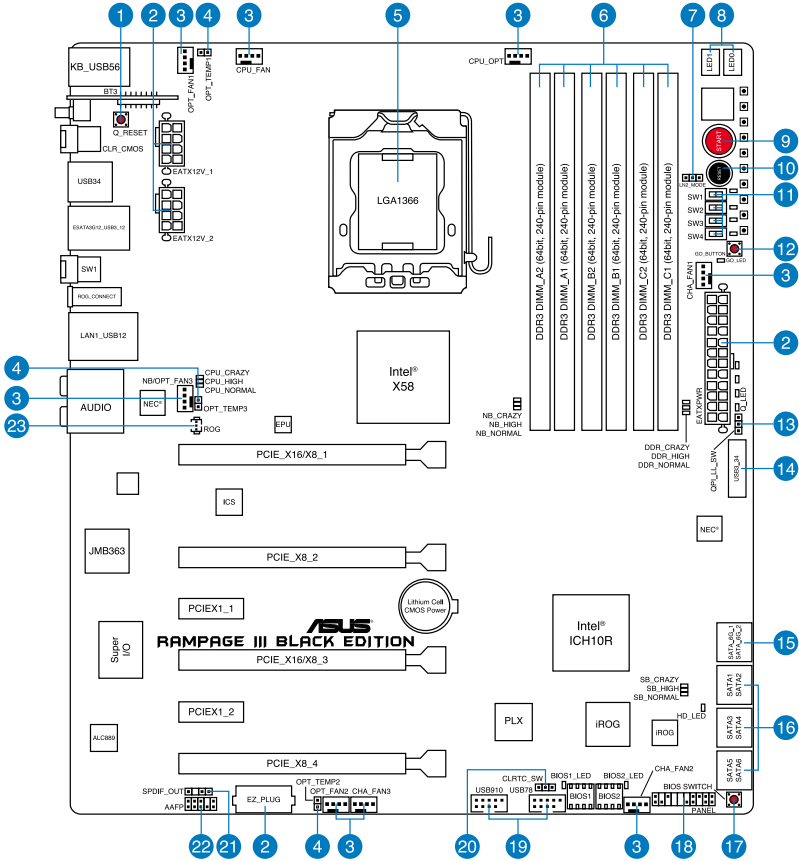

Refer to **2.2.8 Connectors** for more information about rear panel connectors and internal connectors.

## 2.2.2 Layout contents

Connectors/Jumpers/Switches/Slots		Page
1.	Q-Reset Switch	2-21
2.	Power connectors (24-pin EATXPWR, 8-pin EATX12V, 4-pin EZ_PLUG)	2-40
3.	CPU, chassis, and optional fan connectors (4-pin CPU_FAN; 4-pin CPU_OPT; 4-pin CHA_FAN1/2/3; 4-pin OPT_FAN1/2/3)	2-37
4.	Thermal sensor cable connectors (2-pin OPT_TEMP1–3)	2-38
5.	LGA1366 CPU Socket	2-4
6.	DDR3 DIMM slots	2-5
7.	LN2 Mode jumper	2-32
8.	Debug LEDs	2-26
9.	Start Switch	2-19
10.	Reset Switch	2-19
11.	PCIe x16 Lane switch	2-21
12.	GO button	2-20
13.	QPI_LL_SW jumper	2-32
14.	USB 3.0 connector (USB3_34)	2-36
15.	Marvell® Serial ATA 6.0 Gb/s connectors (7-pin SATA6G_E1/E2 [gray])	2-33
16.	ICH10R Serial ATA 3.0 Gb/s connectors (7-pin SATA3G_3–6 [black])	2-34
17.	BIOS switch	2-20
18.	System panel connector (20-8 pin PANEL)	2-41
19.	USB 2.0 connectors (10-1 pin USB78; USB910)	2-35
20.	Clear RTC RAM (3-pin CLRRTC_SW)	2-31
21.	Digital audio connector (4-1 pin SPDIF_OUT)	2-36
22.	Front panel audio connector (10-1 pin AAFP)	2-39
23.	ROG Logo LED connector (3-pin ROG)	2-38

## 2.2.3 Central Processing Unit (CPU)

The motherboard comes with a surface mount LGA1366 socket designed for the Intel® Core™ i7 Processors.

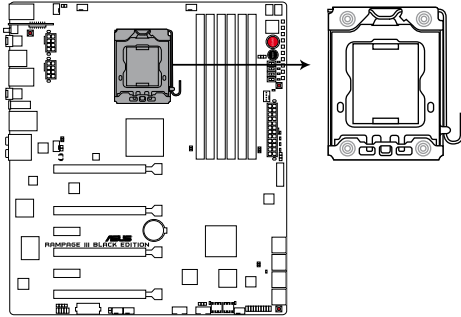

**RAMPAGE III BLACK EDITION CPU LGA1366**



---

Ensure that all power cables are unplugged before installing the CPU.

---



- Upon purchase of the motherboard, ensure that the PnP cap is on the socket and the socket contacts are not bent. Contact your retailer immediately if the PnP cap is missing, or if you see any damage to the PnP cap/socket contacts/motherboard components. ASUS will shoulder the cost of repair only if the damage is shipment/transit-related.
  - Keep the cap after installing the motherboard. ASUS will process Return Merchandise Authorization (RMA) requests only if the motherboard comes with the cap on the LGA1366 socket.
  - The product warranty does not cover damage to the socket contacts resulting from incorrect CPU installation/removal, or misplacement/loss/incorrect removal of the PnP cap.
-

## 2.2.4 System memory

The motherboard comes with six Double Data Rate 3 (DDR3) Dual Inline Memory Modules (DIMM) slots.



A DDR3 module is notched differently from a DDR or DDR2 module. DO NOT install a DDR or DDR2 memory module to the DDR3 slot.

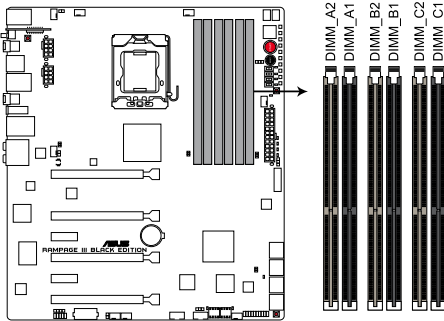

**RAMPAGE III BLACK EDITION 240-pin DDR3 DIMM sockets**

## Memory configurations

You may install 1GB, 2GB and 4GB unbuffered and non-ECC DDR3 DIMMs into the DIMM sockets.



- 
- You may install varying memory sizes in Channel A, Channel B and Channel C. The system maps the total size of the lower-sized channel for the dual-channel or triple-channel configuration. Any excess memory from the higher-sized channel is then mapped for single-channel operation.
  - Due to Intel spec definition, X.M.P. DIMMs and DDR3-1600 are supported for one DIMM per channel only.
  - According to Intel CPU spec, DIMMs with voltage requirement over 1.65V may damage the CPU permanently. We recommend you install the DIMMs with the voltage requirement below 1.65V.
  - Always install DIMMs with the same CAS latency. For optimum compatibility, we recommend that you obtain memory modules from the same vendor.
  - Due to the memory address limitation on 32-bit Windows OS, when you install 4GB or more memory on the motherboard, the actual usable memory for the OS can be about 3GB or less. For effective use of memory, we recommend that you do any of the following:
    - Use a maximum of 3GB system memory if you are using a 32-bit Windows OS.
    - Install a 64-bit Windows OS when you want to install 4GB or more on the motherboard.For more details, refer to the Microsoft® support site at <http://support.microsoft.com/kb/929605/en-us>.
  - This motherboard does not support DIMMs made up of 512 Mb (64MB) chips or less (Memory chip capacity counts in Megabit, 8 Megabit/Mb = 1 Megabyte/MB).
- 



- 
- The default memory operation frequency is dependent on its Serial Presence Detect (SPD), which is the standard way of accessing information from a memory module. Under the default state, some memory modules for overclocking may operate at a lower frequency than the vendor-marked value. To operate at the vendor-marked or at a higher frequency, refer to section 3.3 **Extreme Tweaker** menu for manual memory frequency adjustment.
  - For system stability, use a more efficient memory cooling system to support a full memory load (6 DIMMs) or overclocking condition.
-

## Rampage III Black Edition Motherboard Qualified Vendors Lists (QVL) DDR3-2400MHz capability

Vendors	Part No.	Size	SS/DS	Timing	Voltage	DIMM socket support (Optional)			
						2 DIMM	3 DIMM	4 DIMM	6 DIMM
G.SKILL	F3-19200CL9D-4GBPIS(XMP)	4GB ( 2x 2G )	DS	9-11-11-31	1.65	•			
Patriot	PVV34G2400C9K(XMP)	4GB ( 2x 2GB )	DS	9-11-9-27	1.66	•			

## Rampage III Black Edition Motherboard Qualified Vendors Lists (QVL) DDR3-2333MHz capability

Vendors	Part No.	Size	SS/DS	Timing	Voltage	DIMM socket support (Optional)			
						2 DIMM	3 DIMM	4 DIMM	6 DIMM
KINGSTON	KHX2333C9D3T1K2/4GX(XMP)	4GB ( 2x 2GB )	DS	-	1.65	•			

## Rampage III Black Edition Motherboard Qualified Vendors Lists (QVL) DDR3-2250MHz capability

Vendors	Part No.	Size	SS/DS	Timing	Voltage	DIMM socket support (Optional)			
						2 DIMM	3 DIMM	4 DIMM	6 DIMM
KINGSTON	KHX2250C9D3T1K2/4GX(XMP)	4GB ( 2x 2GB )	DS	-	1.65	•	•		

## Rampage III Black Edition Motherboard Qualified Vendors Lists (QVL) DDR3-2200MHz capability

Vendors	Part No.	Size	SS/DS	Timing	Voltage	DIMM socket support (Optional)			
						2 DIMM	3 DIMM	4 DIMM	6 DIMM
G.SKILL	F3-17600CL7D-4GBFLS(XMP)	4G ( 2x 2G )	DS	7-10-10-28	1.65	•			
GEIL	GET34GB2200C9DC(XMP)	4GB ( 2x 2GB )	DS	9-10-9-28	1.65	•	•		
KINGMAX	FLKE85F-B8KHA(XMP)	4G ( 2x 2G )	DS	-	1.5~1.7	•	•		
KINGMAX	FLKE85F-B8KJAA-FEIS(XMP)	4GB ( 2x 2GB )	DS	-	-	•	•		

## Rampage III Black Edition Motherboard Qualified Vendors Lists (QVL) DDR3-2133MHz capability

Vendors	Part No.	Size	SS/DS	Timing	Voltage	DIMM socket support (Optional)			
						2 DIMM	3 DIMM	4 DIMM	6 DIMM
CORSAIR	CMT4GX3M2A2133C9(XMP)	4GB (2x 2GB)	DS	9-10-9-24	1.65	•	•		
G.SKILL	F3-17066CL9D-4GBTDS(XMP)	4GB (2x 2GB)	DS	-	1.65	•	•		
G.SKILL	F3-17066CL8D-4GBPS(XMP)	4GB(2 x 2GB)	DS	8-8-8-24	1.65	•			
G.SKILL	F3-17066CL9D-4GBTD(XMP)	4GB(2 x 2GB)	DS	9-9-9-24	1.65	•	•		
G.SKILL	F3-17066CL9T-6GB-T	6GB(3 x 2GB)	DS	9-9-9-24	1.65	•	•		
GEIL	GE34GB2133C9DC(XMP)	4GB(2 x 2GB)	DS	9-9-9-28	1.65	•			
GEIL	GU34GB2133C9DC(XMP)	4GB(2 x 2GB)	DS	9-9-9-28	1.65	•	•	•	
KINGSTON	KHX2133C9AD3T1K2/4GX(XMP)	4GB (2x 2GB)	DS	-	1.65	•	•		
KINGSTON	KHX2133C9AD3W1K2/4GX(XMP)	4GB (2x 2GB)	DS	9	1.65	•			
KINGSTON	KHX2133C9D3T1K2/4GX(XMP)	4GB (2x 2GB)	DS	-	1.65	•	•		
KINGSTON	KHX2133C9D3T1K2/4GX(XMP)	4GB(2 x 2GB)	DS	9	1.65	•	•		
Patriot	PVV34G2133C9K(XMP)	4GB (2x 2GB)	DS	9-11-9-27	1.66	•	•		

## Rampage III Black Edition Motherboard Qualified Vendors Lists (QVL) DDR3-2000MHz capability

Vendors	Part No.	Size	SS/DS	Timing	Voltage	DIMM socket support (Optional)			
						2 DIMM	3 DIMM	5 DIMM	6 DIMM
A-DATA	AX3U2000GC4G9B-DG2(XMP)	8GB (2x 4GB)	DS	9-11-9-27	2		•	•	
Apacer	78.AAGD5.9KD(XMP)	6GB(3 x 2GB)	DS	9-9-9-27	-	•	•	•	•
G.SKILL	F3-16000CL9D-4GBRH(XMP)	4GB(2 x 2GB)	DS	9-9-9-24	1.65	•	•	•	
G.SKILL	F3-16000CL9D-4GBTD(XMP)	4GB(2 x 2GB)	DS	9-9-9-24	1.65	•	•	•	
G.SKILL	F3-16000CL7T-6GBPS(XMP)	6GB(3 x 2GB)	DS	7-8-7-20	1.65		•		
G.SKILL	F3-16000CL9T-6GBPS(XMP)	6GB(3 x 2GB)	DS	9-9-9-24	1.65	•	•		
G.SKILL	F3-16000CL9T-6GBTD(XMP)	6GB(3 x 2GB)	DS	9-9-9-24	1.6	•	•	•	
G.SKILL	F3-16000CL7Q-8GBFLS(XMP)	8GB(4 x 2GB)	DS	7-9-7-24	1.65	•	•	•	
GEIL	GUP34GB2000C9DC(XMP)	4GB (2x 2GB)	DS	9-9-9-28	1.65	•	•	•	•
GEIL	GE38GB2000C9QC(XMP)	8GB(4 x 2GB)	DS	9-9-9-28	1.65	•	•	•	•
KINGSTON	KHX2000C9AD3T1K2/4GX(XMP)	4GB (2x 2GB)	DS	9	1.65	•			
KINGSTON	KHX2000C9D3T1K2/4GX(XMP)	4GB (2x 2GB)	DS	-	1.65	•	•	•	
KINGSTON	KHX2000C9AD3T1K3/6GX(XMP)	6GB (3x 2GB)	DS	9	1.65	•	•	•	•
KINGSTON	KHX2000C9AD3T1K3/6GX(XMP)	6GB (3x 2GB)	DS	-	1.65	•	•		
KINGSTON	KHX2000C9AD3W1K3/6GX(XMP)	6GB (3x 2GB)	DS	9	1.65	•			
OCZ	OCZ3B2000LV6GK	6GB(3 x 2GB)	DS	7-8-7	1.65	•			
AEXEA	AXA3ES2G2000LG28V(XMP)	2GB	DS	-	1.65	•	•	•	•
AEXEA	AXA3ES4GK2000LG28V(XMP)	4GB (2x 2GB)	DS	-	1.65	•	•	•	•
Gingle	9CAASS37AZZ01D1	2GB	DS	9-9-9-24	-	•	•		
Patriot	PVT36G2000LLK(XMP)	6GB(3 x 2GB)	DS	8-8-8-24	1.65	•			



Silicon Power	SP002GBLYU200S02(XMP)	2GB	DS	-	-	•			
Team	TXD32048M2000C9(XMP)	2GB	DS	9-9-9-24	1.5	•	•	•	
Team	TXD32048M2000C9-L(XMP)	2GB	DS	9-9-9-24	1.5	•	•	•	
Team	TXD32048M2000C9-L(XMP)	2GB	DS	9-9-9-24	1.6	•			

## Rampage III Black Edition Motherboard Qualified Vendors Lists (QVL) DDR3-1866MHz capability

Vendors	Part No.	Size	SS/DS	Timing	Voltage	DIMM socket support (Optional)			
						2 DIMM	3 DIMM	4 DIMM	6 DIMM
A-DATA	AX3U1866PB2G8-DP2(XMP)	2GB	DS	8-8-8-24	1.55~1.75	•	•		
CORSAIR	TR3X6G1866C9DVer4.1(XMP)	6GB(3 x 2GB)	DS	9-9-9-24	1.65	•			
G.SKILL	F3-15000CL9D-4GBTD(XMP)	4GB(2 x 2GB)	DS	9-9-9-24	1.65	•	•	•	
KINGSTON	KHX1866C9D3T1K3/3GX(XMP)	3GB ( 3x 1GB )	SS	-	1.65	•	•	•	
KINGSTON	KHX1866C9D3T1K3/6GX(XMP)	6GB(3 x 2GB)	DS	9	1.65	•	•	•	
OCZ	OCZ3RPR1866C9LV3GK	3GB ( 3x 1GB )	DS	9-9-9	1.65	•			
OCZ	OCZ3G1866LV4GK	4GB ( 2x 2GB )	DS	10-10-10	1.65	•			
OCZ	OCZ3P1866C9LV6GK	6GB(3 x 2GB)	DS	9-9-9	1.65	•	•	•	
OCZ	OCZ3RPR1866C9LV6GK	6GB(3 x 2GB)	DS	9-9-9	1.65	•	•		
Super Talent	W1866UX2G8(XMP)	2GB(2 x 1GB)	SS	8-8-8-24	-	•	•	•	
Team	TXD32048M1866C9(XMP)	2GB	DS	9-9-9-24	1.65	•	•	•	•

## Rampage III Black Edition Motherboard Qualified Vendors Lists (QVL) DDR3-1800MHz capability

Vendors	Part No.	Size	SS/DS	Timing	Voltage	DIMM socket support (Optional)			
						2 DIMM	3 DIMM	4 DIMM	6 DIMM
G.SKILL	F3-14400CL6D-4GBFLS(XMP)	4GB(2 x 2GB)	DS	6-8-6-24	1.65	•	•	•	
G.SKILL	F3-14400CL9D-4GBRL(XMP)	4GB(2 x 2GB)	DS	9-9-9-24	1.6	•	•	•	
KINGSTON	KHX1800C9D3T1K3/6GX(XMP)	6GB(3 x 2GB)	DS	-	1.65	•	•	•	•

## Rampage III Black Edition Motherboard Qualified Vendors Lists (QVL) DDR3-1600MHz capability

Vendors	Part No.	Size	SS/DS	Timing	Voltage	DIMM socket support (Optional)			
						2 DIMM	3 DIMM	4 DIMM	6 DIMM
A-DATA	AX3U1600GC4G9-DG2(XMP)	8GB ( 2x 4GB )	DS	9-9-9-24	2	*	*	*	*
CORSAIR	HX3X12G1600C9(XMP)	12GB ( 6x 2GB )	DS	9-9-9-24	1.6	*	*	*	*
CORSAIR	CMG4GX3M2A1600C6	4GB ( 2x 2GB )	DS	6-6-6-18	1.65	*	*	*	*
CORSAIR	CMD4GX3M2B1600C8	4GB( 2x 2GB )	DS	8-8-8-24	1.65	*	*	*	*
CORSAIR	CMG4GX3M2A1600C6	4GB( 2x 2GB )	DS	6-6-6-18	1.65	*	*	*	*
CORSAIR	CMX4GX3M2A1600C8(XMP)	4GB( 2x 2GB )	DS	8-8-8-24	1.65	*	*	*	*
CORSAIR	CMD4GX3M2A1600C8(XMP)	4GB(2 x 2GB)	DS	8-8-8-24	1.65	*	*	*	*
CORSAIR	CMG4GX3M2A1600C7(XMP)	4GB(2 x 2GB)	DS	7-7-7-20	1.65	*	*	*	*
CORSAIR	CMP6GX3M3A1600C8(XMP)	6GB ( 3x 2GB )	DS	8-8-8-24	1.65	*	*	*	*
CORSAIR	CMP6GX3M3A1600C8(XMP)	6GB ( 3x 2GB )	DS	8-8-8-24	1.65	*	*	*	*
CORSAIR	CMX6GX3M3C1600C7(XMP)	6GB ( 3x 2GB )	DS	7-8-7-20	1.65	*	*	*	*
CORSAIR	TR3X6G1600C8D(XMP)	6GB(3 x 2GB)	DS	8-8-8-24	1.65	*	*	*	*
CORSAIR	CMX8GX3M4A1600C9(XMP)	8GB(4 x 2GB)	DS	9-9-9-24	1.65	*	*	*	*
Crucial	BL12864BN1608.8FF(XMP)	2GB( 2x 1GB )	SS	8-8-8-24	1.65	*	*	*	*
Crucial	BL25664BN1608.16FF(XMP)	2GB	DS	8-8-8-24	1.65	*	*	*	*
G.SKILL	F3-12800CL9D-4GBNQ(XMP)	4GB ( 2x 2GB )	DS	9-9-9-24	1.5	*	*	*	*
G.SKILL	F3-12800CL7D-4GBECO(XMP)	4GB(2 x 2GB)	DS	7-8-7-24	-	*	*	*	*
G.SKILL	F3-12800CL7D-4GBRH(XMP)	4GB(2 x 2GB)	DS	7-7-7-24	1.65	*	*	*	*
G.SKILL	F3-12800CL8D-4GBRM(XMP)	4GB(2 x 2GB)	DS	8-8-8-24	1.6	*	*	*	*
G.SKILL	F3-12800CL9D-4GBECO(XMP)	4GB(2 x 2GB)	DS	9-9-9-24	1.35	*	*	*	*
G.SKILL	F3-12800CL8T-6GBPI(XMP)	6GB(3 x 2GB)	DS	8-8-8-21	1.6~1.65	*	*	*	*
G.SKILL	F3-12800CL7D-8GBRH(XMP)	8GB ( 2x 4GB )	DS	7-8-7-24	1.6	*	*	*	*
G.SKILL	F3-12800CL9D-8GBRL(XMP)	8GB ( 2x 4GB )	DS	9-9-9-24	1.5	*	*	*	*
G.SKILL	F3-12800CL8D-8GBECO(XMP)	8GB ( 2x4GB )	DS	8-8-8-24	1.35	*	*	*	*
GEIL	GET316GB1600C9QC(XMP)	16GB ( 4x 4GB )	DS	9-9-9-28	1.6	*	*	*	*
GEIL	GE34GB1600C9DC(XMP)	4GB ( 2x 2GB )	DS	9-9-9-28	1.6	*	*	*	*
GEIL	GV34GB1600C8DC(XMP)	4GB(2 x 2GB)	DS	8-8-8-28	1.6	*	*	*	*
GEIL	GVP38GB1600C8QC(XMP)	8GB ( 4x 2GB )	DS	8-8-8-28	1.6	*	*	*	*
KINGMAX	FLGD45F-B8MF7(XMP)	1GB	SS	-	-	*	*	*	*
KINGSTON	KHX1600C9D3K3/12GX(XMP)	12GB( 3x 4GB )	DS	-	1.65	*	*	*	*
KINGSTON	KHX1600C7D3K2/4GX(XMP)	4GB ( 2x 2GB )	DS	-	1.65	*	*	*	*
KINGSTON	KHX1600C8D3K2/4GX(XMP)	4GB ( 2x 2GB )	DS	8	1.65	*	*	*	*
KINGSTON	KHX1600C9D3K2/4GX(XMP)	4GB ( 2x 2GB )	DS	-	1.65	*	*	*	*
KINGSTON	KHX1600C9D3K2/4GX(XMP)	4GB ( 2x 2GB )	DS	-	1.65	*	*	*	*
Kingston	KHX1600C9D3LK2/4GX(XMP)	4GB ( 2x 2GB )	DS	-	1.65	*	*	*	*
KINGSTON	KHX1600C9D3K3/6GX(XMP)	6GB ( 3x 2GB )	DS	9	1.65	*	*	*	*
KINGSTON	KHX1600C9D3T1K3/6GX(XMP)	6GB ( 3x 2GB )	DS	-	1.65	*	*	*	*
OCZ	OCZ3P1600LV3GK	3GB(3 x 1GB)	SS	7-7-7	1.65	*	*	*	*

OCZ	OCZ3G16004GK	4GB ( 2x 2GB )	DS	8-8-8	1.7	*			
OCZ	OCZ3BE1600C8LV4GK	4GB( 2x 2GB )	DS	8-8-8	1.65	*			
OCZ	OCZ3BE1600C8LV4GK	4GB( 2x 2GB )	DS	8-8-8	1.65	*	*	*	
OCZ	OCZ3OB1600LV4GK	4GB(2 x 2GB)	DS	9-9-9	1.65	*	*	*	
OCZ	OCZ3P1600LV4GK	4GB(2 x 2GB)	DS	7-7-7	1.65	*	*		
OCZ	OCZ3X1600LV4GK(XMP)	4GB(2 x 2GB)	DS	8-8-8	1.65	*	*	*	
OCZ	OCZ3FXE1600C7LV6GK	6GB ( 3x 2GB )	DS	7-7-7	1.65	*	*		
OCZ	OCZ3FXE1600C7LV6GK	6GB(3 x 2GB)	DS	7-7-7	1.65	*	*		
OCZ	OCZ3G1600LV6GK	6GB(3 x 2GB)	DS	8-8-8	1.65	*	*		
OCZ	OCZ3X1600LV6GK(XMP)	6GB(3 x 2GB)	DS	8-8-8	1.65	*	*	*	*
OCZ	OCZ3X1600LV6GK(XMP)	6GB(3 x 2GB)	DS	8-8-8	1.65	*	*	*	*
Super Talent	WP160UX4G8(XMP)	4GB(2 x 2GB)	DS	8	-	*	*		
Super Talent	WP160UX4G9(XMP)	4GB(2 x 2GB)	DS	9	-	*	*	*	*
Super Talent	WB160UX6G8(XMP)	6GB(3 x 2GB)	DS	-	-	*	*	*	*
Super Talent	WB160UX6G8(XMP)	6GB(3 x 2GB)	DS	8	-	*	*	*	*
AEXEA	AXA3PS2G1600S18V(XMP)	2GB	DS	-	1.65	*	*	*	*
AEXEA	AXA3PS4GK1600S18V(XMP)	4GB ( 2x 2GB )	DS	-	1.65	*	*	*	*
Asint	SLZ3128M8-EGJ1D(XMP)	2GB	DS	-	-	*	*	*	*
EK Memory	EKM324L28BP8-116(XMP)	4GB( 2x 2GB )	DS	9	-	*	*	*	*
EK Memory	EKM324L28BP8-116(XMP)	4GB(2 x 2GB)	DS	9	-	*	*	*	*
GoodRam	GR1600D364L9/2G	2GB	DS	-	-	*	*	*	*
KINGTIGER	KTG2G1600PG3(XMP)	2GB	DS	-	-	*	*	*	*
Mushkin	996805(XMP)	4GB ( 2x 2GB )	DS	6-8-6-24	1.65	*	*	*	*
Mushkin	998805(XMP)	6GB ( 3x 2GB )	DS	6-8-6-24	1.65	*	*	*	*
Patriot	PGS34G1600LLKA2	4GB ( 2x 2GB )	DS	8-8-8-24	1.7	*	*	*	*
Patriot	PGS34G1600LLKA	4GB( 2x 2GB )	DS	7-7-7-20	1.7	*	*	*	*
PATRIOT	PGS34G1600LLKA	4GB(2 x 2GB)	DS	7-7-7-20	1.7	*	*	*	*
Patriot	PVT36G1600LLK(XMP)	6GB(3 x 2GB)	DS	8-8-8-24	1.65	*	*	*	*
Team	TXD31024M1600C8-D(XMP)	1GB	SS	8-8-8-24	1.65	*	*	*	*
Team	TXD32048M1600C7-L(XMP)	2GB	DS	7-7-7-24	1.65	*	*	*	*
Team	TXD32048M1600HC8-D(XMP)	2GB	DS	8-8-8-24	1.65	*	*	*	*

## Rampage III Black Edition Motherboard Qualified Vendors Lists (QVL) DDR3-1333MHz capability

Vendors	Part No.	Size	SS/DS	Timing	Voltage	DIMM socket support (Optional)			
						2 DIMM	3 DIMM	4 DIMM	6 DIMM
Apacer	78.01GC6.9L0	1GB	SS	9	-	*	*	*	*
Apacer	78.A1GC6.9L1	2GB	DS	9	-	*	*	*	*
CORSAIR	TW3X4G1333C9A	4GB (2x 2GB)	DS	9-9-9-24	1.5	*	*	*	*
CORSAIR	CMX8GX3M2A1333C9(XMP)	8GB (2x 4GB)	DS	9-9-9-24	1.5	*	*	*	*
CORSAIR	CMX8GX3M4A1333C9	8GB(4 x 2GB)	DS	9-9-9-24	1.5	*	*	*	*
Crucial	CT12864BA1339.8FF	1GB	SS	9	-	*	*	*	*
Crucial	BL25664BN1337.16FF(XMP)	2GB	DS	7-7-7-24	1.65	*	*	*	*
Crucial	CT25664BA1339.16FF	2GB	DS	9	-	*	*	*	*
Crucial	CT25672BA1339.18FF	2GB	DS	9	-	*	*	*	*
ELPIDA	EBJ10UE8BDF0-DJ-F	1GB	SS	-	-	*	*	*	*
ELPIDA	EBJ10UE8EDF0-DJ-F	1GB	SS	-	-	*	*	*	*
ELPIDA	EBJ21UE8BDF0-DJ-F	2GB	DS	-	-	*	*	*	*
G.SKILL	F3-10600CL9D-4GBNT	4GB (2x 2GB)	DS	9-9-9-24	1.5	*	*	*	*
G.SKILL	F3-10666CL8D-4GBHK(XMP)	4GB (2x 2GB)	DS	8-8-8-21	1.5	*	*	*	*
G.SKILL	F3-10666CL7D-4GBRH(XMP)	4GB (2 x 2GB)	DS	7-7-7-21	1.5	*	*	*	*
G.SKILL	F3-10666CL8D-4GBECO(XMP)	4GB (2 x 2GB)	DS	8-8-8-24	1.35	*	*	*	*
G.SKILL	F3-10666CL9D-8GBRL	8GB (2x 4GB)	DS	9-9-9-24	1.5	*	*	*	*
G.SKILL	F3-10666CL9D-8GBRL	8GB (2x 4GB)	DS	9-9-9-24	1.5	*	*	*	*
GEIL	GET316GB1333C9QC	16GB (4x 4GB)	DS	9-9-9-24	1.5	*	*	*	*
GEIL	GG34GB1333C9DC	4GB (2x 2GB)	DS	9-9-9-24	1.3	*	*	*	*
GEIL	GB34GB1333C7DC	4GB (2 x 2GB)	DS	7-7-7-24	1.5	*	*	*	*
GEIL	GG34GB1333C9DC	4GB (2 x 2GB)	DS	9-9-9-24	1.3	*	*	*	*
GEIL	GV34GB1333C7DC	4GB (2 x 2GB)	DS	7-7-7-24	1.5	*	*	*	*
GEIL	GVP38GB1333C7QC	8GB (4x 2GB)	DS	7-7-7-24	1.5	*	*	*	*
Hynix	HMT112U6TFR8A-H9	1GB	SS	-	-	*	*	*	*
Hynix	HMT325U6BFR8C-H9	2GB	SS	-	-	*	*	*	*
Hynix	HMT125U6BFR8C-H9	2GB	DS	9	-	*	*	*	*
Hynix	HMT125U6TFR8A-H9	2GB	DS	-	-	*	*	*	*
Hynix	HMT351U6BFR8C-H9	4GB	DS	-	-	*	*	*	*
KINGMAX	FLFE85F-C8KM9	2GB	SS	-	-	*	*	*	*
KINGMAX	FLFE85F-B8KL9	2GB	DS	-	-	*	*	*	*
KINGMAX	FLFF65F-C8KM9	4GB	DS	-	-	*	*	*	*
Kingston	KVR1333D3N9/1G	1GB	SS	9	1.5	*	*	*	*
Kingston	KVR1333D3N9/2G	2GB	DS	9	1.5	*	*	*	*
Kingston	KHX1333C9D3UK2/4GX(XMP)	4GB (2x 2GB)	DS	9	1.25	*	*	*	*
KINGSTON	KVR1333D3N9K2/4G	4GB (2x 2GB)	DS	-	1.5	*	*	*	*
MICRON	MT8JTF25664AZ-1G4D1	2GB	SS	-	-	*	*	*	*
MICRON	MT8JTF25664AZ-1G4D1	2GB	SS	-	-	*	*	*	*

MICRON	MT16JTF51264AZ-1G4D1	4GB	DS	-	-	•	•	•	•
OCZ	OCZ3RPR13332GK	2GB (2x 1GB)	SS	6-6-6	1.75	•	•	•	
OCZ	OCZ3P1333LV3GK	3GB(3 x 1GB)	SS	7-7-7	1.65	•	•	•	•
OCZ	OCZ3G1333LV4GK	4GB (2x 2GB)	DS	9-9-9	1.65	•	•	•	
OCZ	OCZ3G1333ULV4GK	4GB (2x 2GB)	DS	8-8-8	1.35	•			
OCZ	OCZ3P1333LV4GK	4GB (2x 2GB)	DS	-	1.65	•			
OCZ	OCZ3RPR13334GK	4GB (2x 2GB)	DS	6-6-6	1.75	•			
OCZ	OCZ3G1333ULV4GK	4GB(2 x 2GB)	DS	8-8-8	1.65	•			
OCZ	OCZ3P1333LV4GK	4GB(2 x 2GB)	DS	7-7-7	1.65	•	•		
OCZ	OCZX1333LV6GK(XMP)	6GB(3 x 2GB)	DS	8-8-8	1.6	•	•	•	•
OCZ	OCZ3G1333LV8GK	8GB (2x 4GB)	DS	9-9-9	1.65	•	•	•	
OCZ	OCZ3G1333LV8GK	8GB (2x 4GB)	DS	9-9-9	1.65	•	•	•	
OCZ	OCZ3RPR1333C9LV8GK	8GB (2x 4GB)	DS	9-9-9	1.65	•	•	•	
PSC	PC310600U-9-10-A0	1GB	SS	-	-	•	•	•	•
PSC	AL8F8G73D-DG1	2GB	DS	-	-	•	•	•	•
PSC	PC310600U-9-10-B0	2GB	DS	-	-	•	•	•	•
SAMSUNG	M378B2873EH1-CH9	1GB	SS	-	-	•	•	•	•
SAMSUNG	M378B2873FHS-CH9	1GB	SS	-	-	•	•	•	•
SAMSUNG	M378B5773DH0-CH9	2GB	SS	-	-	•	•	•	•
SAMSUNG	M378B5673FH0-CH9	2GB	DS	-	-	•	•	•	•
SAMSUNG	M378B5273BH1-CH9	4GB	DS	9	-	•	•	•	•
SAMSUNG	M378B5273CH0-CH9	4GB	DS	K4B2G0846C	-	•	•	•	•
SAMSUNG	M378B5273DH0-CH9	4GB	DS	-	-	•	•	•	•
SAMSUNG	M378B1G73AH0-CH9	8GB	DS	-	-	•	•	•	•
ACTICA	ACT1GHU64B8F1333S	1GB	SS	-	-	•	•	•	•
ACTICA	ACT1GHU72C8G1333S	1GB	SS	-	-	•	•	•	•
ACTICA	ACT2GHU64B8G1333M	2GB	DS	-	-	•	•	•	•
ACTICA	ACT2GHU64B8G1333S	2GB	DS	-	-	•	•	•	•
ACTICA	ACT2GHU72D8G1333M	2GB	DS	-	-	•	•	•	•
ACTICA	ACT2GHU72D8G1333S	2GB	DS	-	-	•	•	•	•
ACTICA	ACT4GHU64B8H1333H	4GB	DS	-	-	•	•	•	•
ACTICA	ACT4GHU72D8H1333H	4GB	DS	-	-	•	•	•	•
BUFFALO	D3U1333-1G	1GB	SS	-	-	•	•	•	•
BUFFALO	FSH1333D3G-T3G(XMP)	3GB(3 x 1GB)	SS	7-7-7-20	-	•	•	•	•
BUFFALO	D3U1333-2G	2GB	DS	-	-	•	•	•	•
BUFFALO	D3U1333-4G	4GB	DS	-	-	•	•	•	•
EK Memory	EKM324L28BP8-113	4GB(2 x 2GB)	DS	9	-	•	•	•	•
Elixir	M2F2G64CB88B7N-CG	2GB	SS	-	-	•	•	•	•
Elixir	M2F4G64CB88B5N-CG	4GB	DS	-	-	•	•	•	•
GoodRam	GR1333D364L9/2G	2GB	DS	-	-	•	•	•	•

KINGTIGER	F10DA2T1680	2GB	DS	-	-	•	•	•
KINGTIGER	KTG2G1333PG3	2GB	DS	-	-	•	•	•
Patriot	PGS34G1333LLKA	4GB(2 x 2GB)	DS	7-7-7-20	1.7	•	•	•
Patriot	PVS34G1333ELK	4GB(2 x 2GB)	DS	9-9-9-24	1.5	•		
Patriot	PVS34G1333LLK	4GB(2 x 2GB)	DS	7-7-7-20	1.7	•	•	
PQI	N/A	2GB	DS	-	-	•	•	•
Silicon Power	SP001GBLTE133S01	1GB	SS	-	-	•	•	•
Silicon Power	SP001GBLTU133S01	1GB	SS	-	-	•	•	•
Silicon Power	SP002GBLTE133S01	2GB	DS	-	-	•	•	•
Silicon Power	SP002GBLTU133S02	2GB	DS	9	-	•	•	•
Team	TXD31024M1333C7(XMP)	1GB	SS	7-7-7-21	1.75	•	•	•
Team	TXD31048M1333C7-D(XMP)	1GB	SS	7-7-7-21	1.75	•	•	•
Team	TXD32048M1333C7-D(XMP)	2GB	DS	7-7-7-21	1.5-1.6	•	•	•
Team	TXD32048M1333C7-D(XMP)	2GB	DS	7-7-7-21	1.5-1.6	•	•	•

## Rampage III Black Edition Motherboard Qualified Vendors Lists (QVL) DDR3-1067MHz capability

Vendors	Part No.	Size	SS/DS	Timing	Voltage	DIMM socket support (Optional)			
						2 DIMM	3 DIMM	4 DIMM	6 DIMM
ELPIDA	EBJ11UD8BAFA-AG-E	1GB	DS	8	-	•	•	•	
Hynix	HYMT112U64ZNF8-G7	1GB	SS	7	-	•	•	•	
Hynix	HYMT125U64ZNF8-G7	2GB	DS	7	-	•	•	•	
WINTEC	3DU3191A-10	1GB	DS	7	-	•	•	•	
Hynix	HMT112U6AFP8C-G7N0	1GB	SS	7	-	•	•	•	
Hynix	HMT125U6AFP8C-G7N0	2GB	DS	7	-	•	•	•	
Crucial	CT25664BA1067.16SFD	2GB	DS	7	-	•	•	•	
Crucial	CT12864BA1067.8SFD	1GB	SS	7	-	•	•	•	
SAMSUNG	M378B5273BH1-CF8	4GB	DS	8	1.5	•			
ELPIDA	EBJ10UE8BAW0-AE-E	1GB	SS	7	-	•	•	•	
ELPIDA	EBJ21UE8BAW0-AE-E	2GB	DS	7	-	•	•	•	
MICRON	MT&JTF12864AZ-1G1F1	1GB	SS	7	-	•	•	•	
MICRON	MT16JTF25664AZ-1G1F1	2GB	DS	7	-	•	•	•	
Crucial	CT12872BA1067.9FF	1GB	SS	7	-	•	•		
MICRON	MT9JSF12872AZ-1G1F1	1GB	SS	7	-	•	•	•	
Crucial	CT25672BA1067.18FF	2GB	DS	7	-	•	•	•	
MICRON	MT18JSF25672AZ-1G1F1	2GB	DS	7	-	•	•	•	

Crucial	CT12864BA1067.8FF	1GB	SS	7	-	•	•	•	•
Crucial	CT25664BA1067.16FF	2GB	DS	7	-	•	•	•	•
ELPIDA	EBJ10UE8EDF0-AE-F	1GB	SS	-	-	•	•	•	•
ELPIDA	EBJ21UE8EDF0-AE-F	2GB	DS	-	-	•	•	•	•
Elixir	M2Y2G64CB8HC5N-BE	2GB	DS	-	-	•	•	•	•
Elixir	M2Y2G64CB8HC9N-BE	2GB	DS	-	-	•	•	•	•
Kingston	KVR1066D3N7/1G	1GB	SS	7	1.5	•	•	•	•
Kingston	KVR1066D3N7/2G	2GB	DS	7	1.5	•	•	•	•
GEIL	GG34GB1066C8DC	4GB (2x 2GB)	DS	8-8-8-20	1.3	•	•	•	•
KINGSTON	KVR1066D3N7K2/4G	4GB (2x 2GB)	DS	-	1.5	•	•	•	•



---

### 6 DIMM Slots:

- 2 DIMMs: Supports two (2) modules inserted into slot A1 and B1 as one pair of Dual-channel memory configuration.
  - 3 DIMMs: Supports three (3) modules inserted into the black slots (A1, B1 and C1) as one set of Triple-channel memory configuration
  - 4 DIMMs: Supports four (4) modules inserted into the black slots (A1, B1 and C1) and the gray slot A2 as one set of Triple-channel memory configuration.
  - 6 DIMMs: Supports six (6) modules inserted into both the gray slots and the black slots as two set of Triple-channel memory configuration.
-

## 2.2.5 Expansion slots

In the future, you may need to install expansion cards. The following sub-sections describe the slots and the expansion cards that they support.



---

Ensure to unplug the power cord before adding or removing expansion cards. Failure to do so may cause you physical injury and damage motherboard components.

---

### Installing an expansion card

To install an expansion card:

1. Before installing the expansion card, read the documentation that came with it and make the necessary hardware settings for the card.
2. Remove the system unit cover (if your motherboard is already installed in a chassis).
3. Remove the bracket opposite the slot that you intend to use. Keep the screw for later use.
4. Align the card connector with the slot and press firmly until the card is completely seated on the slot.
5. Secure the card to the chassis with the screw you removed earlier.
6. Replace the system cover.

### Configuring an expansion card

After installing the expansion card, configure it by adjusting the software settings.

1. Turn on the system and change the necessary BIOS settings, if any. See Chapter 3 for information on BIOS setup.
2. Assign an IRQ to the card. Refer to the tables on the next page.
3. Install the software drivers for the expansion card.



---

When using PCI cards on shared slots, ensure that the drivers support “Share IRQ” or that the cards do not need IRQ assignments. Otherwise, conflicts will arise between the two PCI groups, making the system unstable and the card inoperable. Refer to the table on the next page for details.

---



## IRQ assignments for this motherboard

	A	B	C	D	E	F	G	H
PCIEX16/X8_1	shared	-	-	-	-	-	-	-
PCIEX8_2	shared	-	-	-	-	-	-	-
PCIEX1_1	-	-	-	shared	-	-	-	-
PCIEX16/X8_3	shared	-	-	-	-	-	-	-
PCIEX1_1	-	shared	-	-	-	-	-	-
PCIEX8_4	shared	-	-	-	-	-	-	-
UHCI Controller 1	-	-	-	-	-	-	-	shared
UHCI Controller 2	-	-	-	shared	-	-	-	-
UHCI Controller 3	-	-	shared	-	-	-	-	-
UHCI Controller 4	shared	-	-	-	-	-	-	-
UHCI Controller 5	-	-	-	-	-	shared	-	-
UHCI Controller 6	shared	-	-	-	-	-	-	-
UHCI Controller 7	-	-	-	shared	-	-	-	-
EHCI Controller 1	-	-	-	-	-	-	-	shared
EHCI Controller 2	-	-	shared	-	-	-	-	-
SATA Controller 1	-	-	shared	-	-	-	-	-
SATA Controller 2	-	-	-	-	shared	-	-	-
HD Audio	-	-	-	-	-	-	shared	-
Onboard SATA Controller	shared	-	-	-	-	-	-	-
GbE Controller	-	-	-	-	-	-	shared	-
Onboard SATA6G Controller	shared	-	-	-	-	-	-	-
Onboard USB 3.0 Controller 1	shared	-	-	-	-	-	-	-
Onboard USB 3.0 Controller 2	-	shared	-	-	-	-	-	-
Wi-Fi	-	shared	-	-	-	-	-	-

## PCI Express x1 slots

This motherboard has one PCI Express x1 slot that supports a PCI Express x1 card complying with the PCI Express specifications. Refer to the figure below for the location of the slot.

## PCI Express x16 slots

This motherboard has four PCI Express x16 slots that support PCI Express x16 cards complying with the PCI Express specifications. Refer to the figure below for the location of the slot.

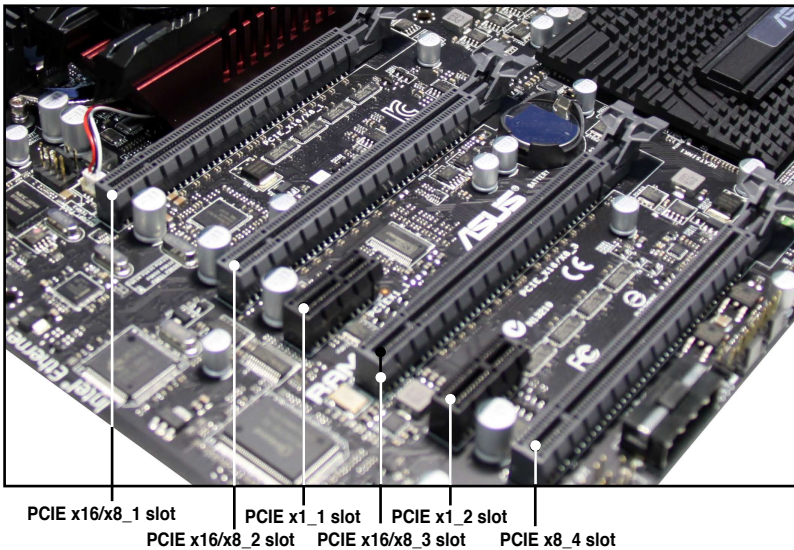

- Refer to the following configuration table for installation.

PCIE x16 Slot #	Single VGA	SLI/CF	3 way SLI/CFX	Quad CFX
1	x16	x16	x8	x8
2	—	—	x8	x8
3	—	x16	x16	x8
4	—	—	—	x8

- We recommend that you provide sufficient power when running CrossFireX™ or SLI mode. See page 2-46 for details.
- Connect a chassis fan to the motherboard connector labeled CHA\_FAN1/2/3 when using multiple graphics cards for better thermal environment.

## 2.2.6 Onboard switches

Onboard switches allow you to fine-tune performance when working on a bare or open-case system. This is ideal for overclockers and gamers who continually change settings to enhance system performance.

### 1. Power-on switch

Press the power-on switch to wake/power up the system.

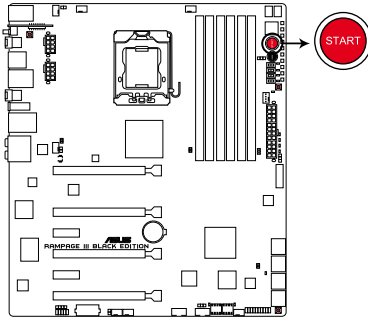

**RAMPAGE III BLACK EDITION Power on switch**

### 2. Reset switch

Press the reset switch to reboot the system.

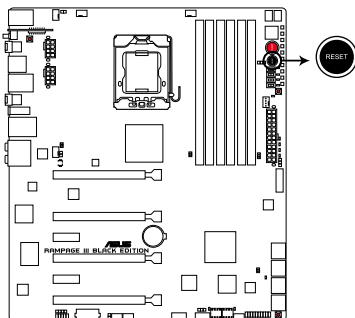

**RAMPAGE III BLACK EDITION Reset switch**

### 3. GO button

Press the GO button before POST to enable MemOK! or press it to quickly load the preset profile (GO\_Button file) for temporary overclocking when in OS.

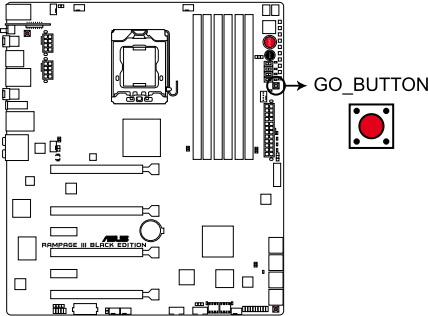

**RAMPAGE III BLACK EDITION GO\_BUTTON**

### 4. BIOS button

The motherboard comes with two BIOS. Press the BIOS button to switch BIOS and load different BIOS settings. The nearby BIOS LEDs indicate the BIOS you are using.

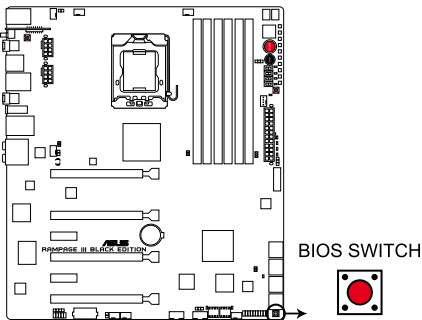

**RAMPAGE III BLACK EDITION BIOS\_BUTTON**

## 5. PCIe x16 Lane switch

These slide switches allows you to enable and disable the corresponding PCIe x16 slots. When one of the installed PCIe x16 cards is out of order, you can use the slide switch to find out the faulty one without removing the cards.

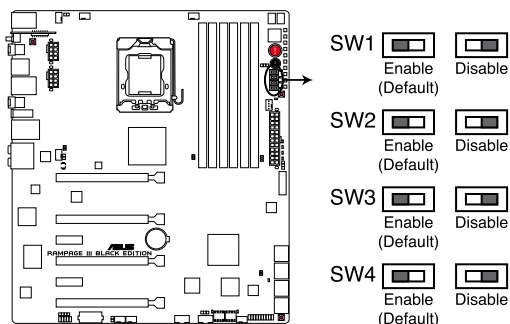

**RAMPAGE III BLACK EDITION SW**

## 6. Q reset button

When the LN2\_Mode jumper does not work and your CPU cannot resume function, press the Q reset button to temporarily stop the power supply to the CPU and help the CPU recover from a frozen condition.

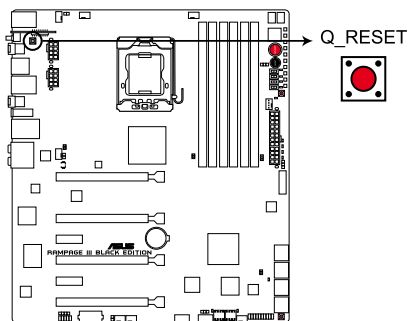

**RAMPAGE III BLACK EDITION Q\_RESET BUTTON**

## 2.2.7 Onboard LEDs

The motherboard comes with a set of LEDs that indicate the voltage conditions of CPU, memory, northbridge and southbridge. You may adjust the voltages in BIOS. There are also an LED for hard disk drive activity and an onboard switch for power status. For more information about voltage adjustment, refer to **3.3 Extreme Tweaker menu**.

### 1. CPU LED

The CPU LED has four voltage displays: CPU Voltage, CPU PLL Voltage, and QPI/DRAM Core Voltage; you can select the voltage to display in BIOS. Refer to the illustration below for the location of the CPU LED and the table below for LED definition.

### 2. Northbridge LED

Northbridge LED has two different voltage displays. The northbridge LED displays either the 1.11V IOH voltage or the 1.50V IOH PCIE voltage. You can select the voltage to display in BIOS. Refer to the illustration below for the location of the northbridge LED and the table below for LED definition.

### 3. Memory LED

The Memory LED has one voltage display: DRAM Voltage. Refer to the illustration below for the location of the memory LED and the table below for LED definition.

### 4. Southbridge LED

Southbridge LED has two different voltage displays. The southbridge LED shows either the 1.11V ICH voltage or the 1.50V ICH PCIE voltage. You can select the voltage to display in BIOS. Refer to the illustration below for the location of the southbridge LED and the table below for LED definition.

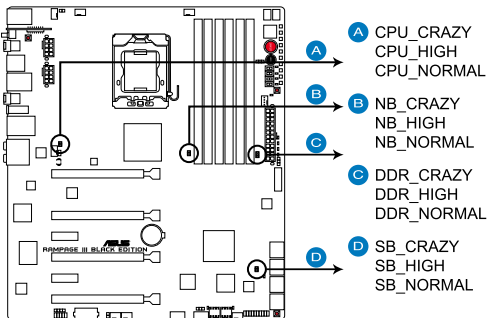

**RAMPAGE III BLACK EDITION CPU/ NB/ DDR/ SB LED**

	Normal (white)	Normal (green)	High (yellow)	Crazy (red)
CPU Voltage (default)		0.85–1.5	1.50625–1.59375	1.6–
CPU PLL	1.20575–1.78875	1.80200–1.89475	1.90800–1.94775	1.96100–
QPI/DRAM Core		1.2–1.39375	1.4–1.65625	1.66250–

	Normal (white)	Normal (green)	High (yellow)	Crazy (red)
DRAM Bus Voltage	1.20575–1.49725	1.51050–1.60325	1.61650–1.78875	1.80200–

	Normal (green)	High (yellow)	Crazy (red)
IOH (default)	1.11300–1.39125	1.40450–1.64300	1.65625–
IOH PCIE	1.51050–1.69600	1.70925–1.84175	1.85500–

	Normal (green)	High (yellow)	Crazy (red)
ICH (default)	1.11300–1.59000	1.60325–1.84175	1.85500–
ICH PCIE	1.51050–1.61650	1.62975–1.80200	1.81525–

## 5. Hard Disk LED

The hard disk LED is designed to indicate the hard disk activity. It blinks when data is being written into or read from the hard disk drive. The LED does not light up when there is no hard disk drive connected to the motherboard or when the hard disk drive does not function.

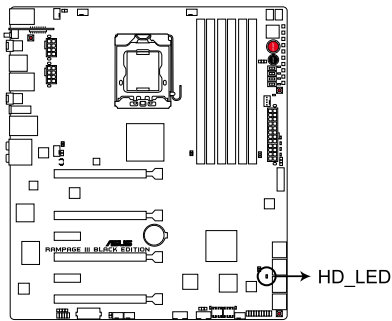

**RAMPAGE III BLACK EDITION Hard Disk LED**

## 6. BIOS LED

The BIOS LEDs help indicate the BIOS activity. Press the BIOS button to switch between BIOS1 and BIOS2 and the LED lights up when the corresponding BIOS is in use.

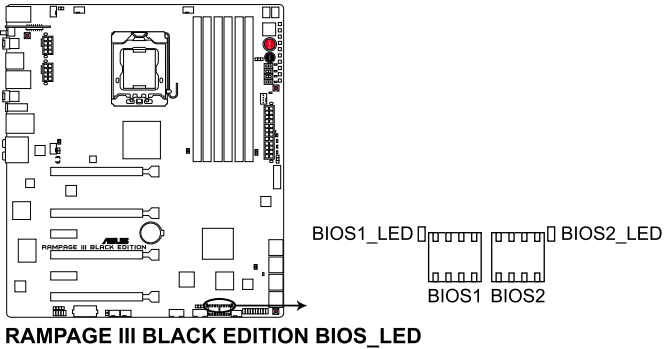

## 7. GO LED

**Blinking:** Indicates that MemOK! is enabled before POST.

**Lighting:** Indicates that the system loads the preset profile (GO\_Button file) for temporary overlocking when in OS.

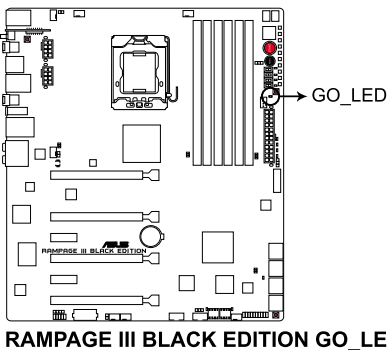



## 8. Q LED

Q LEDs check key components (CPU, DRAM, VGA card, and booting devices) in sequence during motherboard booting process. If an error is found, the corresponding LED will continue lighting until the problem is solved. This user-friendly design provides an intuitional way to locate the root problem within a second.

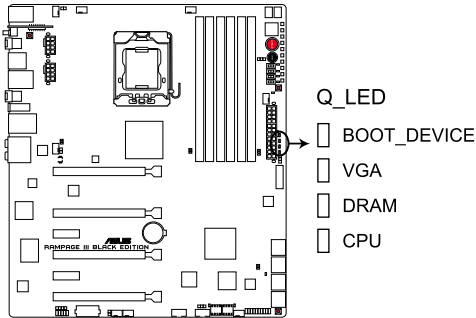

**RAMPAGE III BLACK EDITION CPU/ DRAM/  
VGA/ BOOT\_DEVICE LED**

## 9. Power LED

The motherboard comes with a power-on switch that lights up to indicate that the system is ON, in sleep mode, or in soft-off mode. This is a reminder that you should shut down the system and unplug the power cable before removing or plugging in any motherboard component. The illustration below shows the location of the onboard power-on switch.

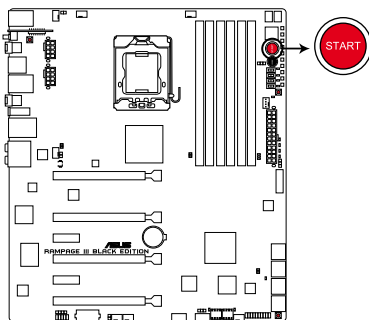

**RAMPAGE III BLACK EDITION Power on switch**

## 10. Debug LEDs

The Debug LED design provides you the 2-digit display, allowing you to know the system status. Refer to the Debug table below for details.

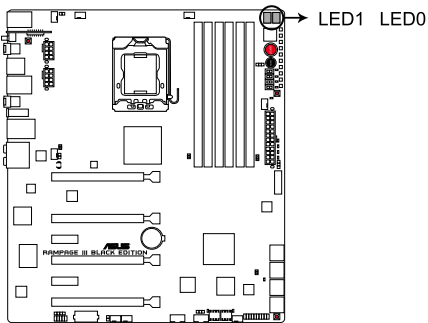

**RAMPAGE III BLACK EDITION Debug LEDs**

### Debug table

Code	Description
00	Not used
01	Power on. Reset type detection (soft/hard).
02	AP initialization before microcode loading
03	System Agent initialization before microcode loading
04	PCH initialization before microcode loading
05	OEM initialization before microcode loading
06	Microcode loading
07	AP initialization after microcode loading
08	System Agent initialization after microcode loading
09	PCH initialization after microcode loading
0A	OEM initialization after microcode loading
0B	Cache initialization
0C – 0D	Reserved for future AMI SEC error codes
0E	Microcode not found
0F	Microcode not loaded
10	PEI Core is started
11 – 14	Pre-memory CPU initialization is started
15 – 18	Pre-memory System Agent initialization is started
19 – 1C	Pre-memory PCH initialization is started

**Debug table (continued)**

Code	Description
1D – 2A	OEM pre-memory initialization codes
2B – 2F	Memory initialization
30	Reserved for ASL (see ASL Status Codes section below)
31	Memory Installed
32 – 36	CPU post-memory initialization
37 – 3A	Post-Memory System Agent initialization is started
3B – 3E	Post-Memory PCH initialization is started
3F – 4E	OEM post memory initialization codes
4F	DXE IPL is started
50 – 53	Memory initialization error. Invalid memory type or incompatible memory speed
54	Unspecified memory initialization error
55	Memory not installed
56	Invalid CPU type or Speed
57	CPU mismatch
58	CPU self test failed or possible CPU cache error
59	CPU micro-code is not found or micro-code update is failed
5A	Internal CPU error
5B	Reset PPI is not available
5C – 5F	Reserved for future AMI error codes
E0	S3 Resume is started (S3 Resume PPI is called by the DXE IPL)
E1	S3 Boot Script execution
E2	Video repost
E3	OS S3 wake vector call
E4 – E7	Reserved for future AMI progress codes
E8	S3 Resume Failed
E9	S3 Resume PPI not Found
EA	S3 Resume Boot Script Error
EB	S3 OS Wake Error
EC – EF	Reserved for future AMI error codes
F0	Recovery condition triggered by firmware (Auto recovery)
F1	Recovery condition triggered by user (Forced recovery)

## Debug table (continued)

Code	Description
F2	Recovery process started
F3	Recovery firmware image is found
F4	Recovery firmware image is loaded
F5-F7	Reserved for future AMI progress codes
F8	Recovery PPI is not available
F9	Recovery capsule is not found
FA	Invalid recovery capsule
FB-FF	Reserved for future AMI error codes
60	DXE Core is started
61	NVRAM initialization
62	Installation of the PCH Runtime Services
63 – 67	CPU DXE initialization is started
68	PCI host bridge initialization
69	System Agent DXE initialization is started
6A	System Agent DXE SMM initialization is started
6B – 6F	System Agent DXE initialization (System Agent module specific)
70	PCH DXE initialization is started
71	PCH DXE SMM initialization is started
72	PCH devices initialization
73 – 77	PCH DXE Initialization (PCH module specific)
78	ACPI module initialization
79	CSM initialization
7A – 7F	Reserved for future AMI DXE codes
80 – 8F	OEM DXE initialization codes
90	Boot Device Selection (BDS) phase is started
91	Driver connecting is started
92	PCI Bus initialization is started
93	PCI Bus Hot Plug Controller Initialization
94	PCI Bus Enumeration
95	PCI Bus Request Resources
96	PCI Bus Assign Resources

Code	Description
97	Console Output devices connect
98	Console input devices connect
99	Super IO Initialization
9A	USB initialization is started
9B	USB Reset
9C	USB Detect
9D	USB Enable
9E – 9F	Reserved for future AMI codes
A0	IDE initialization is started
A1	IDE Reset
A2	IDE Detect
A3	IDE Enable
A4	SCSI initialization is started
A5	SCSI Reset
A6	SCSI Detect
A7	SCSI Enable
A8	Setup Verifying Password
A9	Start of Setup
AA	Reserved for ASL (see ASL Status Codes section below)*
AB	Setup Input Wait
AC	Reserved for ASL (see ASL Status Codes section below)
AD	Ready To Boot event
AE	Legacy Boot event
AF	Exit Boot Services event
B0	Runtime Set Virtual Address MAP Begin
B1	Runtime Set Virtual Address MAP End
B2	Legacy Option ROM Initialization
B3	System Reset
B4	USB hot plug
B5	PCI bus hot plug
B6	Clean-up of NVRAM
B7	Configuration Reset (reset of NVRAM settings)
B8– BF	Reserved for future AMI codes

## Debug table (continued)

Code	Description
C0– CF	OEM BDS initialization codes
D0	CPU initialization error
D1	System Agent initialization error
D2	PCH initialization error
D3	Some of the Architectural Protocols are not available
D4	PCI resource allocation error. Out of Resources
D5	No Space for Legacy Option ROM
D6	No Console Output Devices are found
D7	No Console Input Devices are found
D8	Invalid password
D9	Error loading Boot Option (LoadImage returned error)
DA	Boot Option is failed (StartImage returned error)
DB	Flash update is failed
DC	Reset protocol is not available

## \*ASL Status Codes

Status Code	Description
01	System is entering S1 sleep state
02	System is entering S2 sleep state
03	System is entering S3 sleep state
04	System is entering S4 sleep state
05	System is entering S5 sleep state
10	System is waking up from the S1 sleep state
20	System is waking up from the S2 sleep state
30	System is waking up from the S3 sleep state
40	System is waking up from the S4 sleep state
AC	System has transitioned into ACPI mode. Interrupt controller is in APIC mode
AA	System has transitioned into ACPI mode. Interrupt controller is in APIC mode

## 2.2.8 Jumper

### 1. Clear RTC RAM (3-pin CLRTC)

This jumper allows you to clear the Real Time Clock (RTC) RAM in CMOS. You can clear the CMOS memory of date, time, and system setup parameters by erasing the CMOS RTC RAM data. The onboard button cell battery powers the RAM data in CMOS, which include system setup information such as system passwords.

To erase the RTC RAM

1. Turn OFF the computer and unplug the power cord.
2. Move the jumper cap from pins 1-2 (default) to pins 2-3. Keep the cap on pins 2-3 for about 5–10 seconds, then move the cap back to pins 1-2.
3. Plug the power cord and turn ON the computer.
4. Hold down the <Del> key during the boot process and enter BIOS setup to re-enter data.

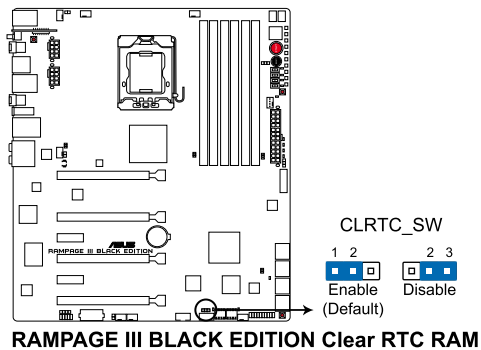

Except when clearing the RTC RAM, never remove the cap on CLRTC jumper default position. Removing the cap will cause system boot failure!



- If the steps above do not help, remove the onboard battery and move the jumper again to clear the CMOS RTC RAM data. After the CMOS clearance, reinstall the battery.
- You do not need to clear the RTC when the system hangs due to overclocking. For system failure due to overclocking, use the C.P.R. (CPU Parameter Recall) feature. Shut down and reboot the system so the BIOS can automatically reset parameter settings to default values.
- Due to the chipset behavior, AC power off is required to enable C.P.R. function. You must turn off and on the power supply or unplug and plug the power cord before rebooting the system.

## 2. LN2 Mode Jumper (3-pin LN2)

With LN2 mode activated, the ROG motherboard is optimized to remedy the cold-boot bug during POST at an extremely low temperature and help the system boot successfully.

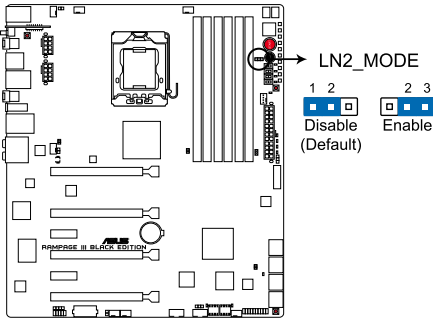

**RAMPAGE III BLACK EDITION LN2\_MODE**

## 3. QPI\_LL\_SW Jumper (3-pin QPI\_LL\_SW)

This jumper prevents QPI voltage from dropping too much when you perform overclocking. The low QPI voltage may cause system malfunction. Set the jumper to pin 2—3 to activate this function and pin 1—2 to disable this function.

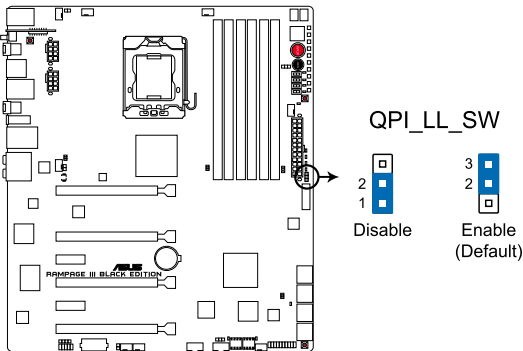

**RAMPAGE III BLACK EDITION QPI\_LL switch**



## 2.2.9 Internal connectors

### 1. Marvell® Serial ATA 6.0 Gb/s connectors (7-pin SATA6G\_E1/2 [gray])

These connectors connect to Serial ATA 6.0 Gb/s hard disk drives via Serial ATA 6.0 Gb/s signal cables.

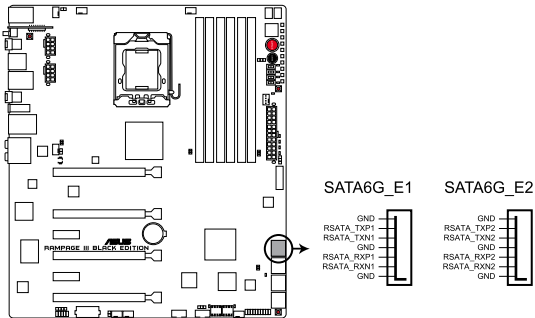

**RAMPAGE III BLACK EDITION SATA6G\_E1/ E2 connectors**



- These connectors are set to [AHCI Mode] by default.
- When using hot-plug and NCQ, set **Onboard SATA6G Controller** in the BIOS to [AHCI Mode]. Refer to section **3.5.3 Onboard Devices Configuration** for details.
- You must install Windows® XP Service Pack 3 or later versions before using Serial ATA hard disk drives.

## 2. ICH10R Serial ATA 3.0 Gb/s connectors (7-pin SATA3G\_1–6 [black])

These connectors connect to Serial ATA 3.0 Gb/s hard disk drives and optical disc drives via Serial ATA 3.0 Gb/s signal cables.

If you installed Serial ATA hard disk drives, you can create a RAID 0, 1, 5, and 10 configuration with the Intel® Rapid Storage Technology through the onboard Intel® ICH10R chipset.

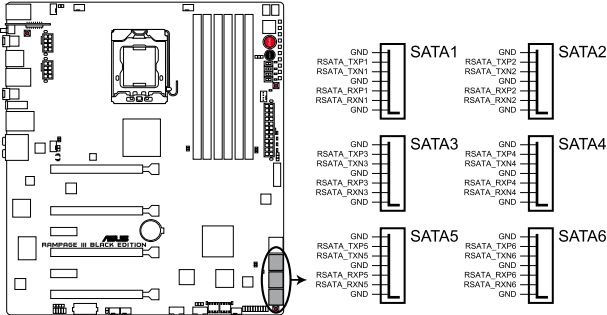

RAMPAGE III BLACK EDITION SATA connectors

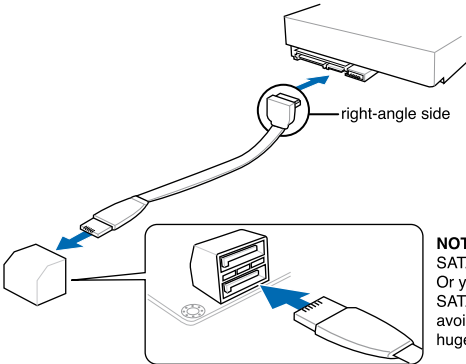

**NOTE:** Connect the right-angle side of SATA signal cable to SATA device. Or you may connect the right-angle side of SATA cable to the onboard SATA port to avoid mechanical conflict with huge graphics cards.



- These connectors are set to [IDE] by default. If you intend to create a Serial ATA RAID set using these connectors, set **Configure SATA as** in the BIOS to [RAID Mode]. Refer to section 3.5.3 **Storage Configuration** for details.
- Before creating a RAID set, refer to section 4.4 **RAID configurations** or the manual bundled in the motherboard support DVD.
- When using hot-plug and NCQ, set **Configure SATA as** in the BIOS to [AHCI Mode]. Refer to section 3.5.3 **Storage Configuration** for details.
- You must install Windows® XP Service Pack 3 or later versions before using Serial ATA hard disk drives. The Serial ATA RAID feature is available only if you are using Windows® XP SP2 or later versions.

### 3. USB 2.0 connectors (10-1 pin USB78; USB910)

These connectors are for USB 2.0 ports. Connect the USB module cable to any of these connectors, then install the module to a slot opening at the back of the system chassis. These USB connectors comply with USB 2.0 specification that supports up to 480 Mbps connection speed.

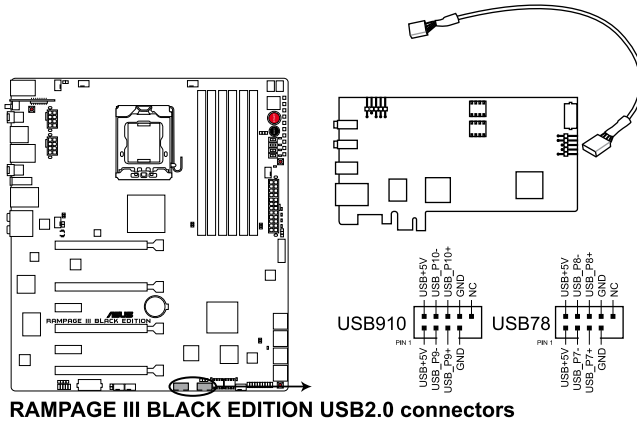

**RAMPAGE III BLACK EDITION USB2.0 connectors**



Never connect a 1394 cable to the USB connectors. Doing so will damage the motherboard!



You can connect the front panel USB cable to the ASUS Q-Connector (USB, blue) first, and then install the Q-Connector (USB) to the USB connector onboard if your chassis supports front panel USB ports.



Connect the ThunderBolt card to the USB connector.

#### 4. USB 3.0 connector (20-1 pin USB3\_910)

This connector is for the additional USB 3.0 ports, and complies with the USB 3.0 specification that supports up to 4.8 Gbps connection speed. If the USB 3.0 front panel cable is available from your system chassis, with this USB 3.0 connector, you can have a front panel USB 3.0 solution.

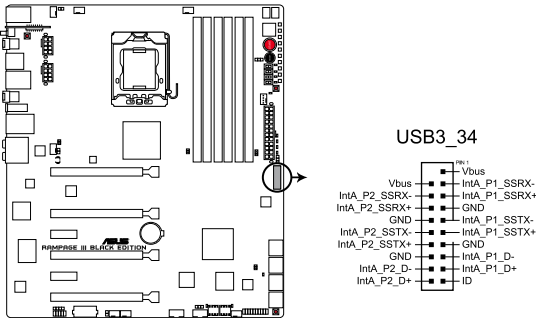

**RAMPAGE III BLACK EDITION USB3.0 connector**



You can connect the ASUS front panel USB 3.0 box to this connector to obtain the front panel USB 3.0 solution.

#### 5. Digital audio connector (4-1 pin SPDIF\_OUT)

This connector is for an additional Sony/Philips Digital Interface (S/PDIF) port(s). Connect the S/PDIF Out module cable to this connector, then install the module to a slot opening at the back of the system chassis.

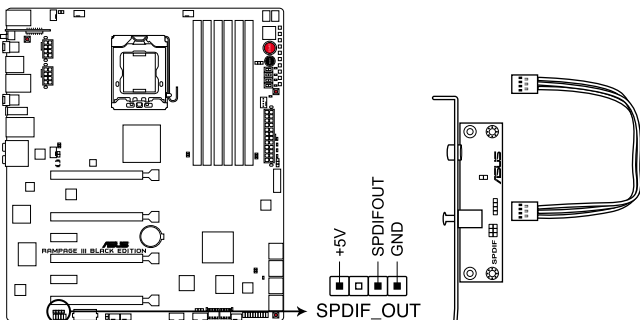

**RAMPAGE III BLACK EDITION Digital audio connector**



The S/PDIF module is purchased separately.

## 6. CPU, chassis, and optional fan connectors (4-pin CPU\_FAN; 4-pin CPU\_OPT; 4-pin CHA\_FAN1/2/3; 4-pin OPT\_FAN1/2/3)

Connect the fan cables to the fan connectors on the motherboard, ensuring that the black wire of each cable matches the ground pin of the connector.

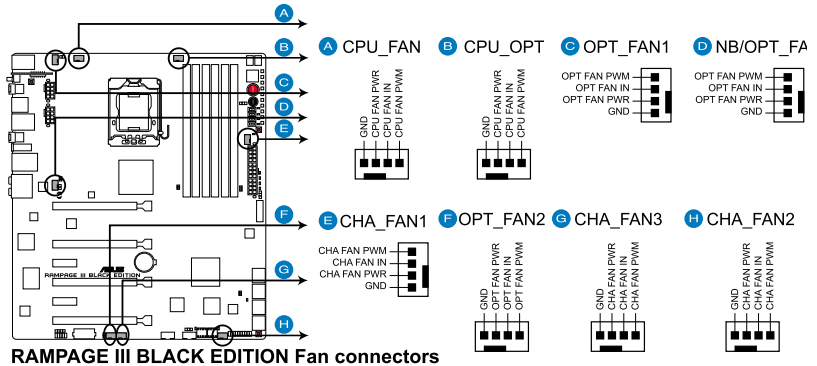

Do not forget to connect the fan cables to the fan connectors. Insufficient air flow inside the system may damage the motherboard components. These are not jumpers! Do not place jumper caps on the fan connectors!



- The CPU\_FAN connector supports the CPU fan of maximum 1A (12 W) fan power.
- If you install two VGA cards, we recommend that you plug the rear chassis fan cable to the motherboard connector labeled OPT\_FAN1/2/3 for better thermal environment.

## 7. Thermal sensor cable connectors (2-pin OPT\_TEMP1/2/3)

These connectors are for temperature monitoring. Connect the thermal sensor cables to these connectors and place the other ends to the devices which you want to monitor temperature. The optional fan1/2/3 can work with the temperature sensors for a better cooling effect.

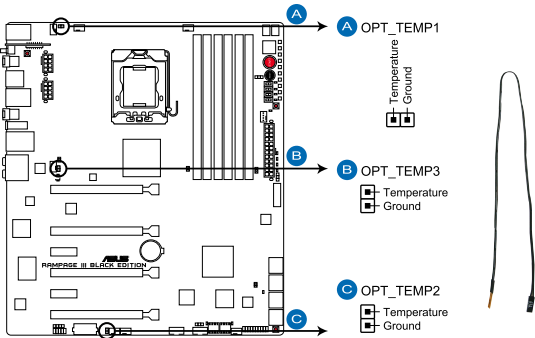

**RAMPAGE III BLACK EDITION Thermal sensor cable connectors**



Enable **OPT FAN1/2/3 overheat protection** in BIOS if you connect thermal sensor cables to these connectors.

## 8. ROG Logo LED connector (3-pin ROG)

This connector is for the box (labeled as Republic of Gamers) on the heatpipe assembly. Connect the cable of the box and it lights when the system is on.

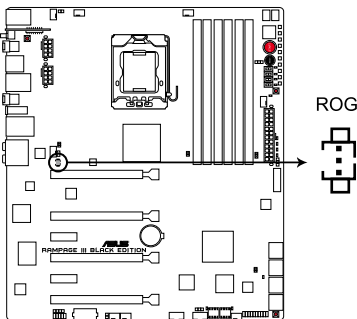

**RAMPAGE III BLACK EDITION ROG Logo LED connector**

## 9. Front panel audio connector (10-1 pin AAFP)

This connector is for a chassis-mounted front panel audio I/O module that supports either HD Audio or legacy AC'97 audio standard. Connect one end of the front panel audio I/O module cable to this connector.

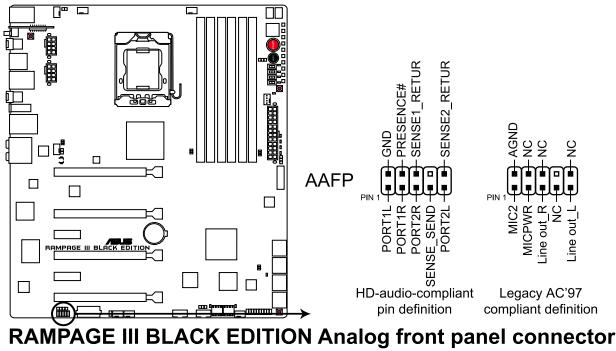

- We recommend that you connect a high-definition front panel audio module to this connector to avail of the motherboard's high-definition audio capability.
- If you want to connect a high-definition front panel audio module to this connector, set the Front Panel Type item in the BIOS setup to [HD]; if you want to connect an AC'97 front panel audio module to this connector, set the item to [AC97]. By default, this connector is set to [HD].

## 10. ATX power connectors (24-pin EATXPWR; 8-pin EATX12V1/2; 4-pin EZ\_PLUG)

These connectors are for ATX power supply plugs. The power supply plugs are designed to fit these connectors in only one orientation. Find the proper orientation and push down firmly until the connectors completely fit.

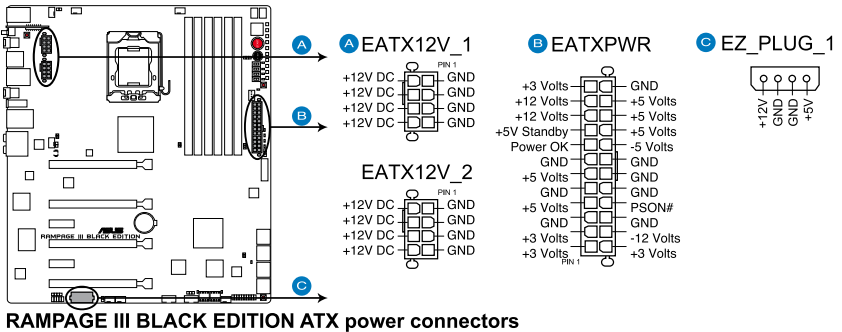

- For a fully configured system, we recommend that you use a power supply unit (PSU) that complies with ATX 12 V Specification 2.0 (or later version) and provides a minimum power of 600 W.
- Do not forget to connect the 8-pin EATX12 V power plug; otherwise, the system will not boot.
- Use of a PSU with a higher power output is recommended when configuring a system with more power-consuming devices. The system may become unstable or may not boot up if the power is inadequate.
- If you are uncertain about the minimum power supply requirement for your system, refer to the Recommended Power Supply Wattage Calculator at <http://support.asus.com/PowerSupplyCalculator/PSCalculator.aspx?SLanguage=en-us> for details.
- If you want to use two or more high-end PCI Express x16 cards, use a PSU with 1000W power or above to ensure the system stability.



## 11. System panel connector (20-8 pin PANEL)

This connector supports several chassis-mounted functions.

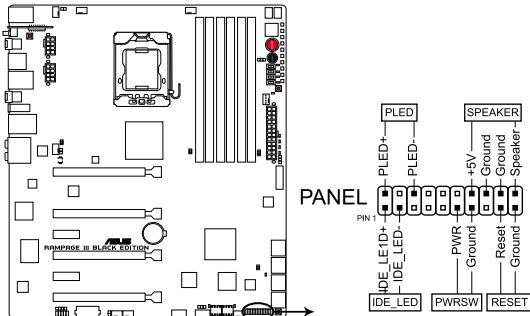

**RAMPAGE III BLACK EDITION System panel connector**

- **System power LED (2-pin PLED)**

This 2-pin connector is for the system power LED. Connect the chassis power LED cable to this connector. The system power LED lights up when you turn on the system power, and blinks when the system is in sleep mode.

- **Hard disk drive activity LED (2-pin IDE\_LED)**

This 2-pin connector is for the HDD Activity LED. Connect the HDD Activity LED cable to this connector. The IDE LED lights up or flashes when data is read from or written to the HDD.

- **System warning speaker (4-pin SPEAKER)**

This 4-pin connector is for the chassis-mounted system warning speaker. The speaker allows you to hear system beeps and warnings.

- **ATX power button/soft-off button (2-pin PWRSW)**





This connector is for the system power button. Pressing the power button turns the system on or puts the system in sleep or soft-off mode depending on the BIOS settings. Pressing the power switch for more than four seconds while the system is ON turns the system OFF.

- **Reset button (2-pin RESET)**

This 2-pin connector is for the chassis-mounted reset button for system reboot without turning off the system power.

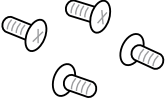
## 2.3 Building your computer system

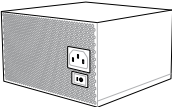
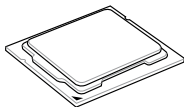
### 2.3.1 Additional tools and components to build a PC system

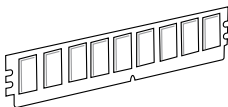
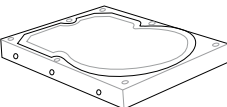
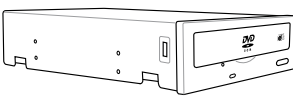
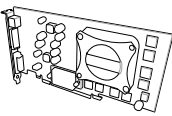
	
1 bag of screws	Philips (cross) screwdriver
	
PC chassis	Power supply unit
	
Intel LGA 1366 CPU	Intel LGA 1366 compatible CPU Fan
	
DIMM	SATA hard disk drive
	
SATA optical disc drive (optional)	Graphics card (optional)



The tools and components in the table above are not included in the motherboard package.

## 2.3.2 CPU installation

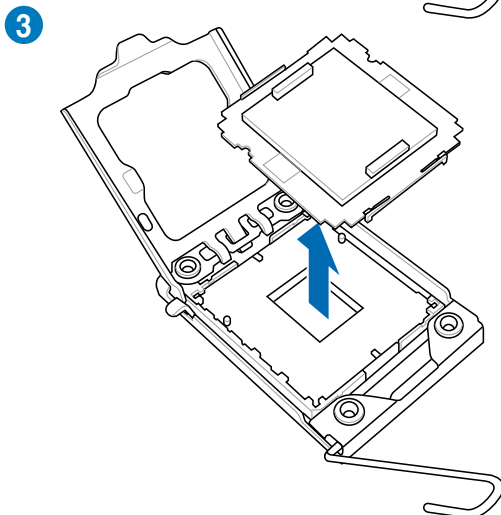
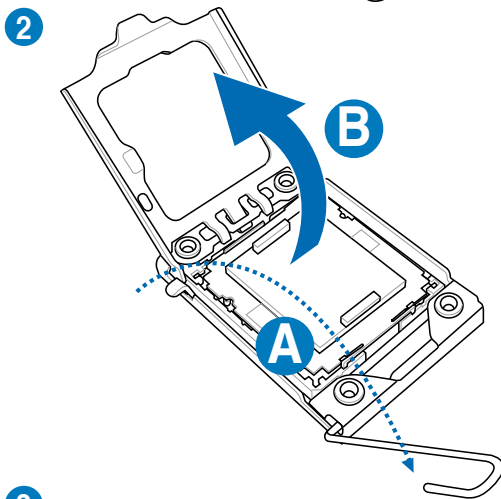
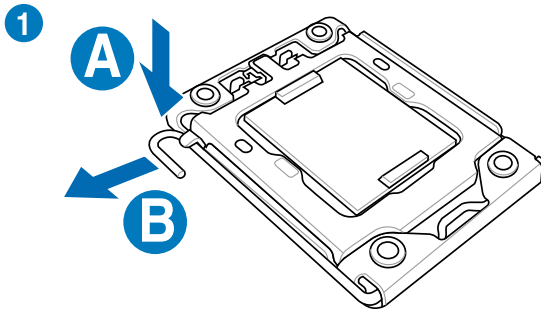

4

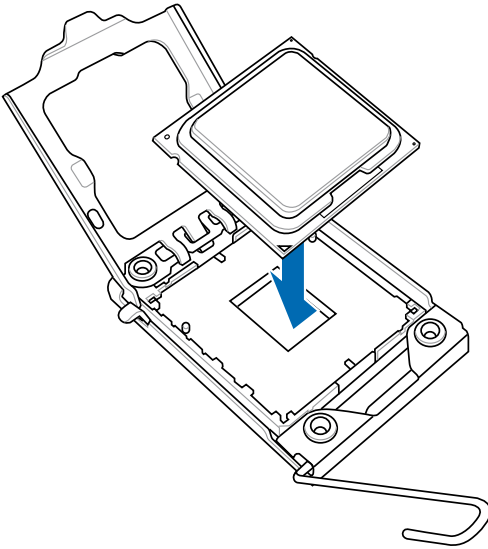

5

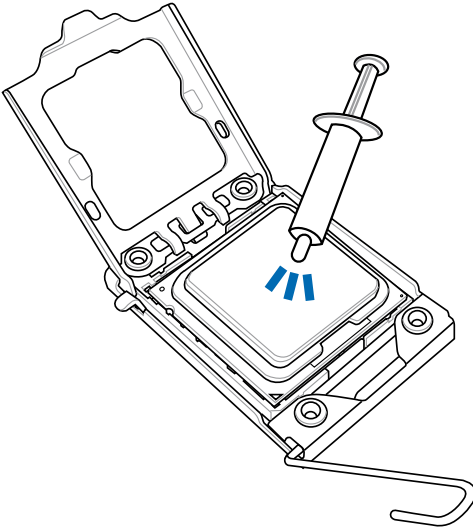

Apply the Thermal Interface Material to the CPU heatsink and CPU before you install the heatsink and fan if necessary.

### 2.3.3 CPU heatsink and fan assembly installation

To install the CPU heatsink and fan assembly

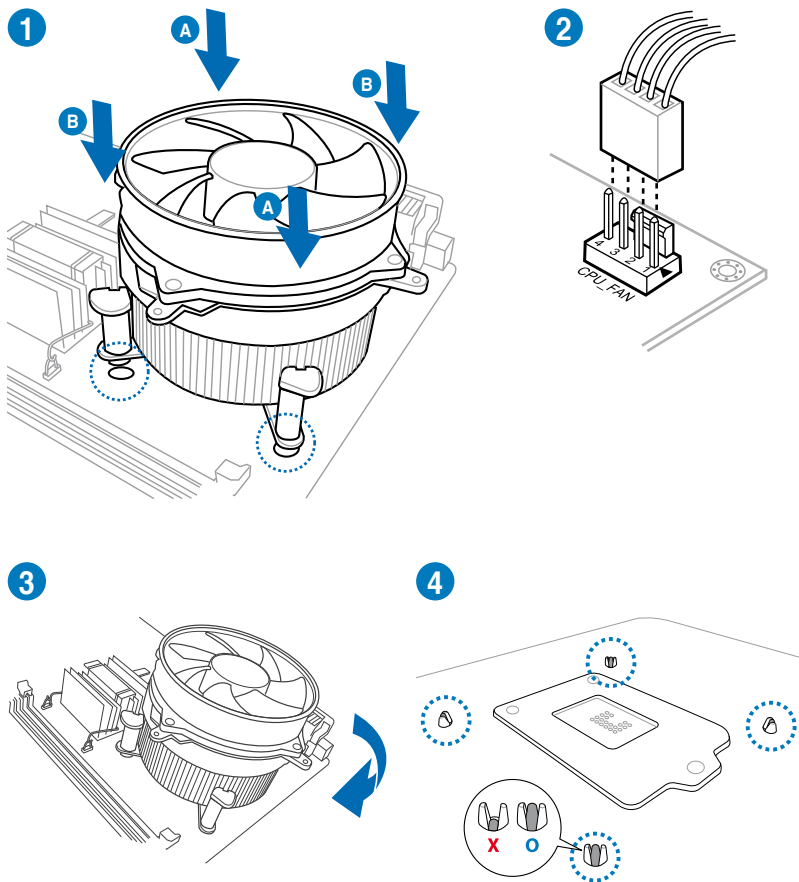

## To uninstall the CPU heatsink and fan assembly

1

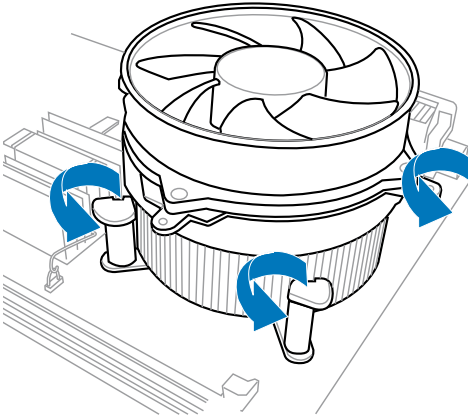

2

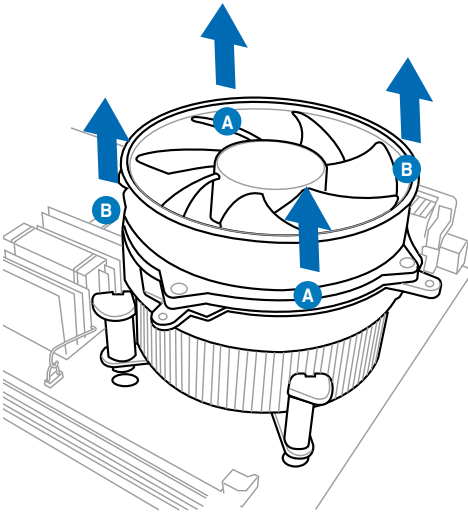

### 2.3.4 DIMM installation

1

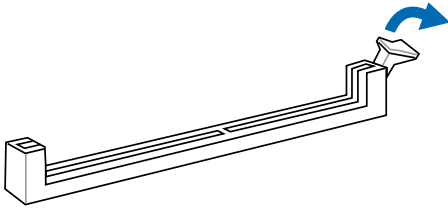

2

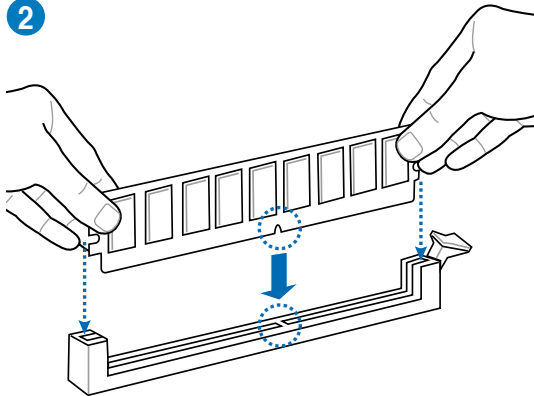

3

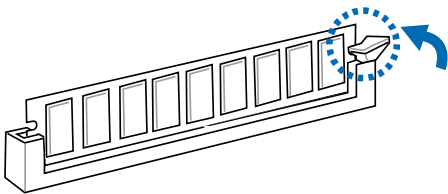

#### To remove a DIMM

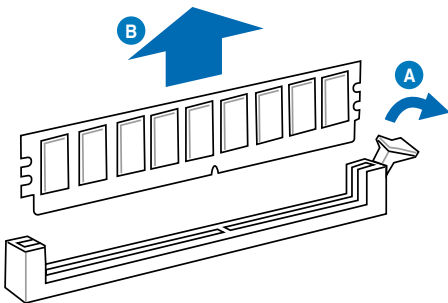

## 2.3.5 Motherboard installation



The diagrams in this section are for reference only. The motherboard layout may vary with models, but the installation steps remain the same.

1

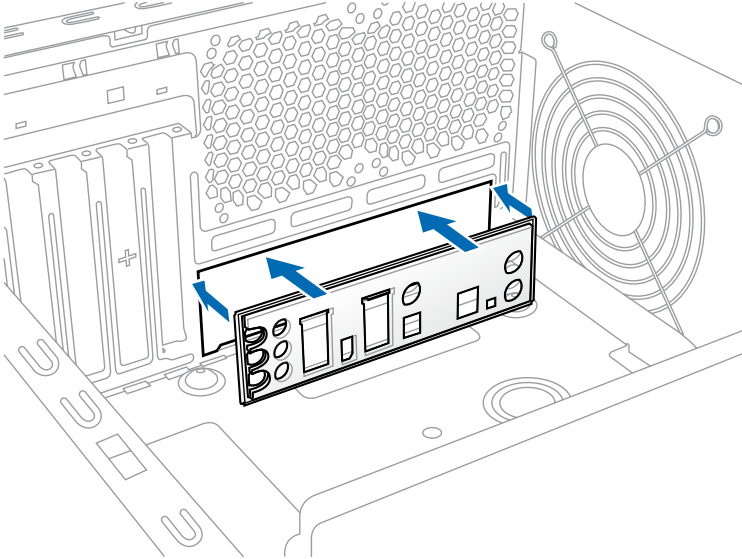

2

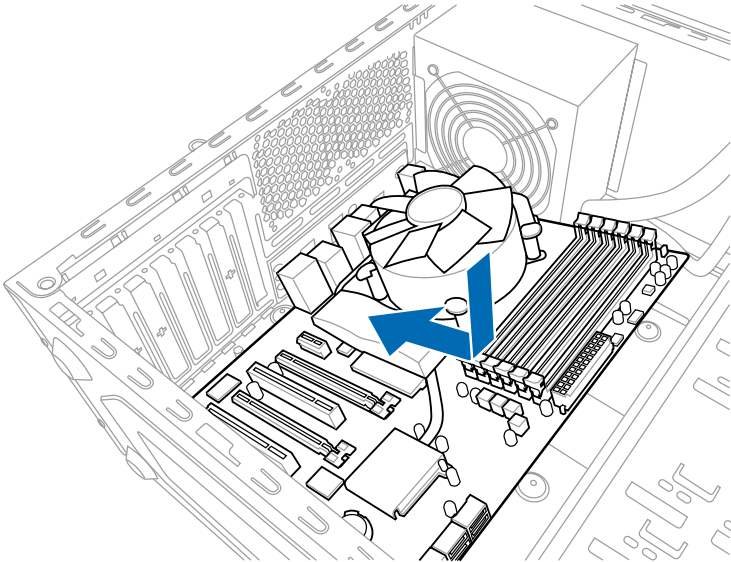



3

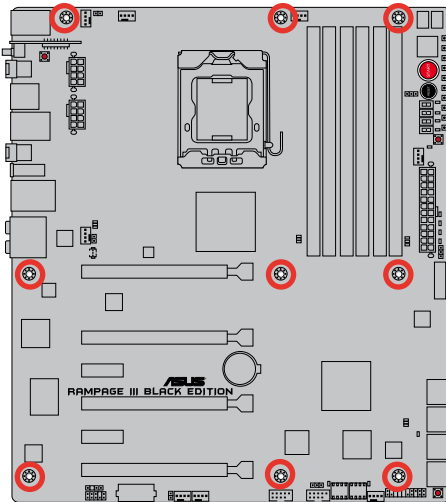
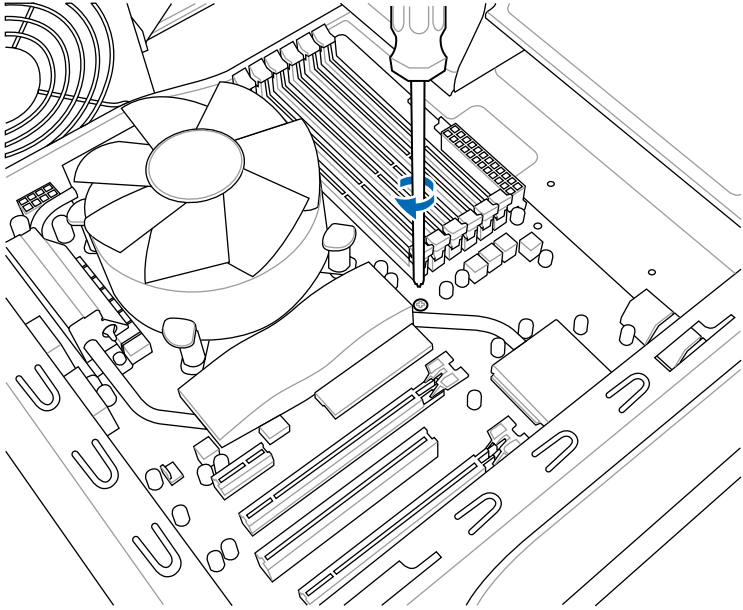

DO NOT overtighten the screws! Doing so can damage the motherboard.

## 2.3.6 ATX Power connection

1

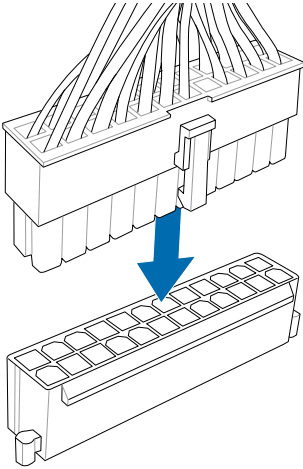

2

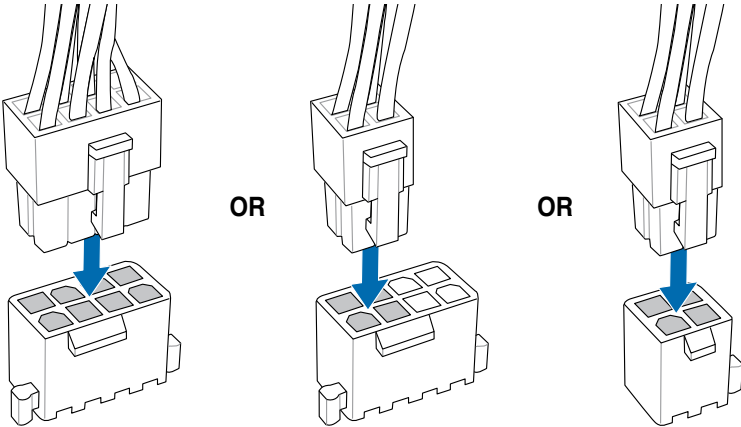

## 2.3.7 SATA device connection

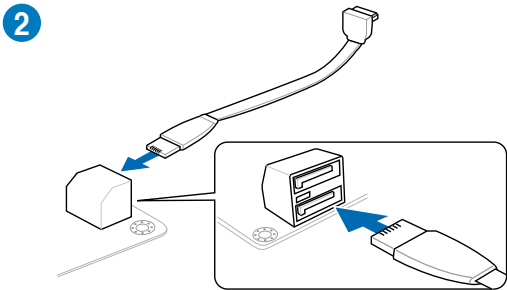
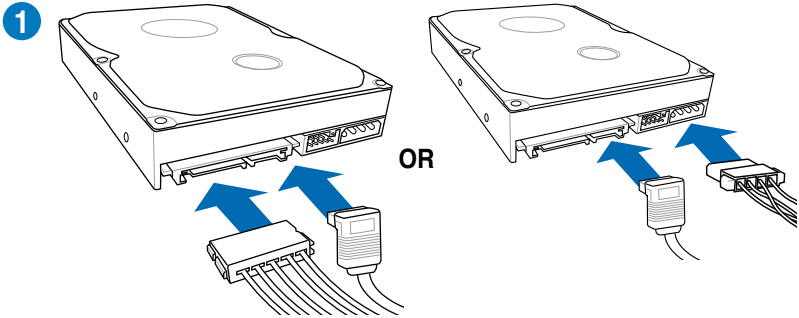

OR

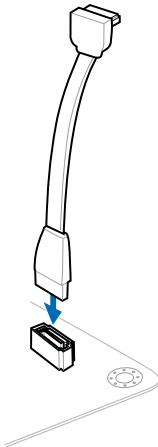

## 2.3.8 Front I/O Connector

### To install ASUS Q-Connector

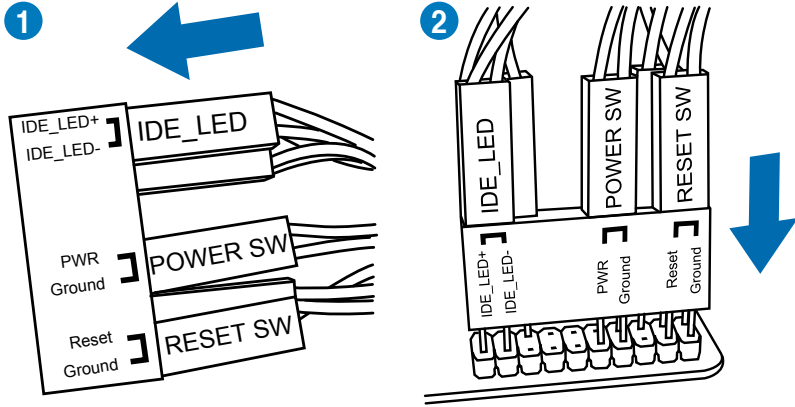

### To install USB Connector

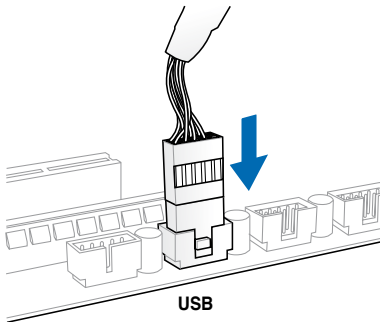

### To install front panel audio connector

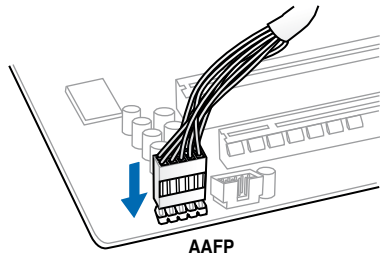

## 2.3.9 Expansion Card installation

To install PCIe x16 cards

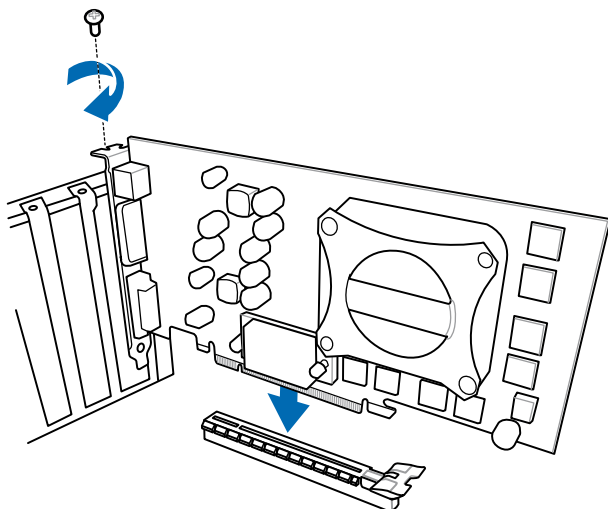

To install PCIe x1 cards

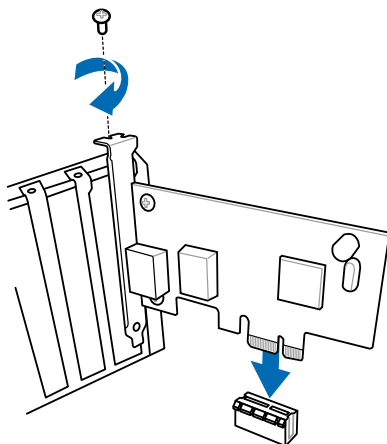

To install PCI cards

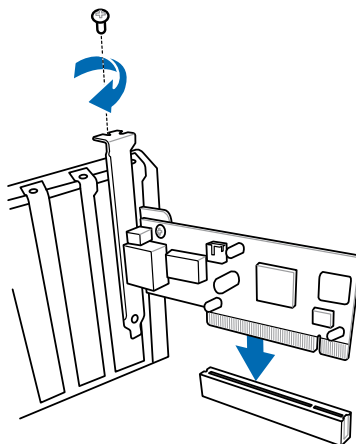

### 2.3.10 ThunderBolt

Combining a dedicated Network Processing Unit (NPU) and a built-in headphone amplifier, ThunderBolt provides you with a best solution to online games, a maximum game performance and less lag problems.

#### Installing ThunderBolt

1. Locate the most suitable PCIe x1 or PCIe x16 slot for the ThunderBolt. You can either install ThunderBolt to the PCIe x1 slot or the PCIe x16 slot.

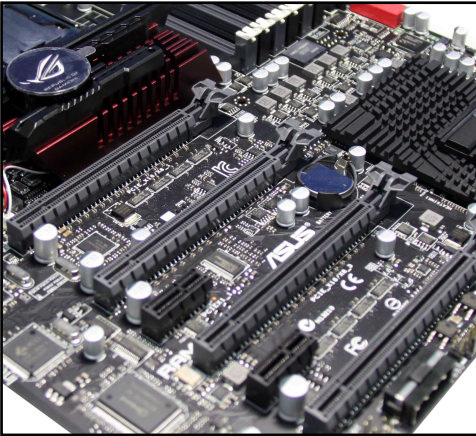

2. Align the card connector with the slot and press firmly until the card sits on the slot completely.

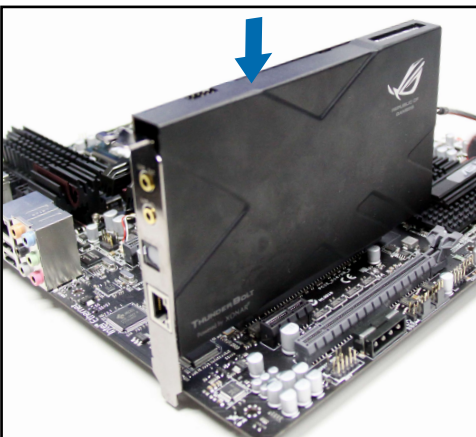

3. Connect the USB cable to the onboard USB connector.

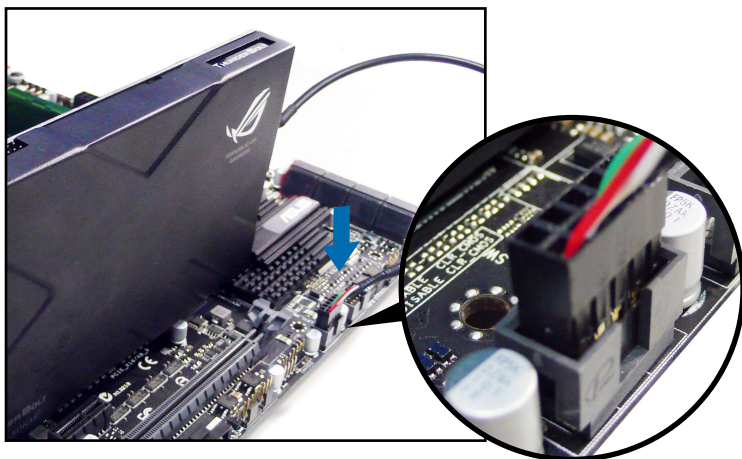

4. Connect the 4-pin molex power connector to the ThunderBolt.

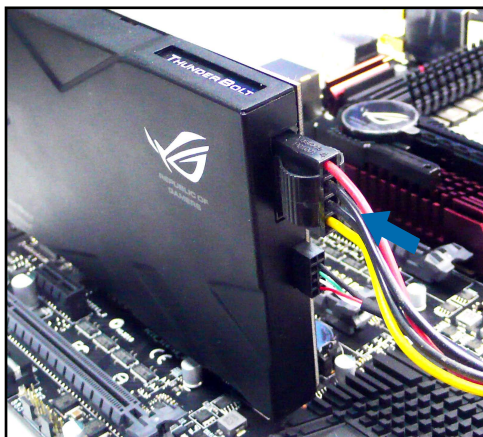

- Ensure to connect the AAFP cable from the chassis front panel to the ThunderBolt AAFP connector.
- Install the ThunderBolt on the PCIE x16/x8 slot for a better LAN performance.

## 2.3.11 Rear panel connection

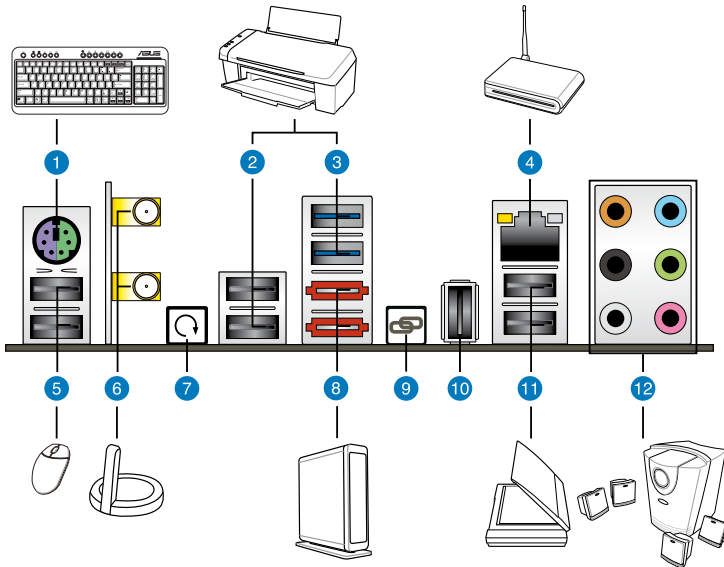

Rear panel connectors	
1. PS/2 mouse and keyboard port	7. Clear CMOS switch
2. USB 2.0 ports 3 and 4	8. External SATA port 1 and 2
3. USB 3.0 ports 1 and 2	9. ROG Connect switch
4. LAN (RJ-45) port*	10. ROG Connect port
5. USB 2.0 ports 5 and 6	11. USB 2.0 ports 1 and 2
6. Wi-Fi Ring Moving Antenna jacks 1 and 2	12. Audio I/O ports**

\*and \*\*: Refer to the tables on the next page for LAN port and audio port definitions.





- Due to USB 3.0 controller limitation, USB 3.0 devices can only be used under Windows® OS environment and after the USB 3.0 driver installation.
- USB 3.0 devices can only be used as data storage only.
- We strongly recommend that you connect USB 3.0 devices to USB 3.0 ports for faster and better performance for your USB 3.0 devices.

### \* LAN port LED indications

Activity Link LED		Speed LED	
Status	Description	Status	Description
OFF	No link	OFF	10 Mbps connection
ORANGE	Linked	ORANGE	100 Mbps connection
BLINKING	Data activity	GREEN	1 Gbps connection

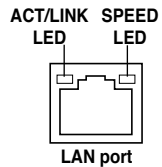

### \*\*Audio 2, 4, 6, or 8-channel configuration

Port	Headset 2-channel	4-channel	6-channel	8-channel
Light Blue	Line In	Line In	Line In	Line In
Lime	Line Out	Front Speaker Out	Front Speaker Out	Front Speaker Out
Pink	Mic In	Mic In	Mic In	Mic In
Orange	–	–	Center/Subwoofer	Center/Subwoofer
Black	–	Rear Speaker Out	Rear Speaker Out	Rear Speaker Out
Gray	–	–	–	Side Speaker Out

## 2.3.12 Audio I/O connections

### Audio I/O ports



### Connect to Headphone and Mic



## Connect to Stereo Speakers

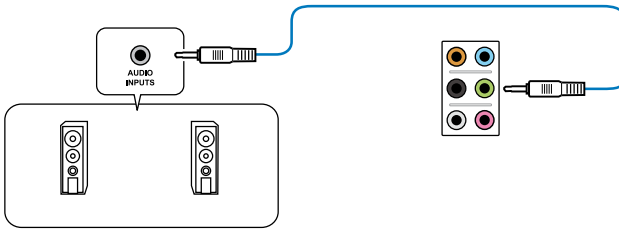

## Connect to 2.1 channel Speakers

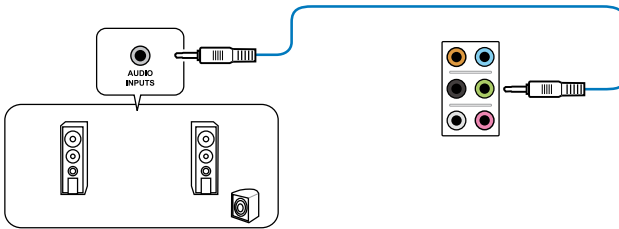

## Connect to 4.1 channel Speakers

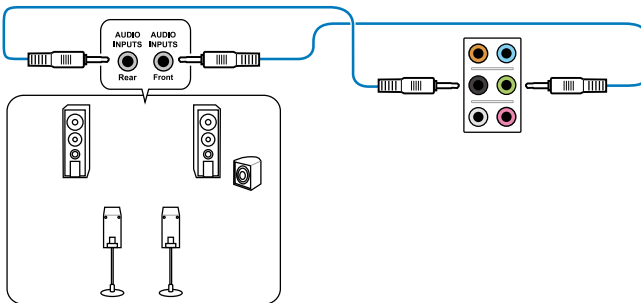

## Connect to 5.1 channel Speakers

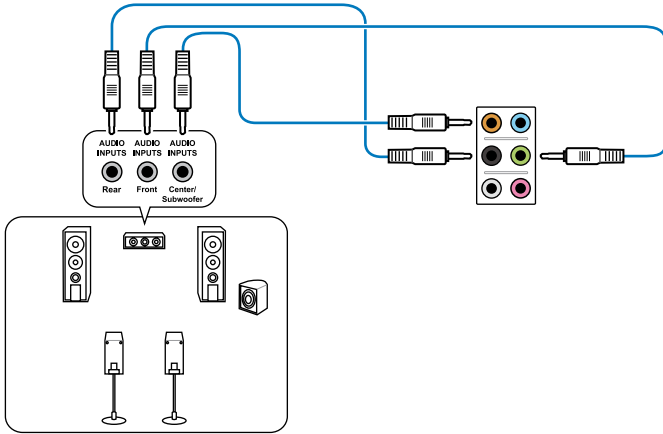

## Connect to 7.1 channel Speakers

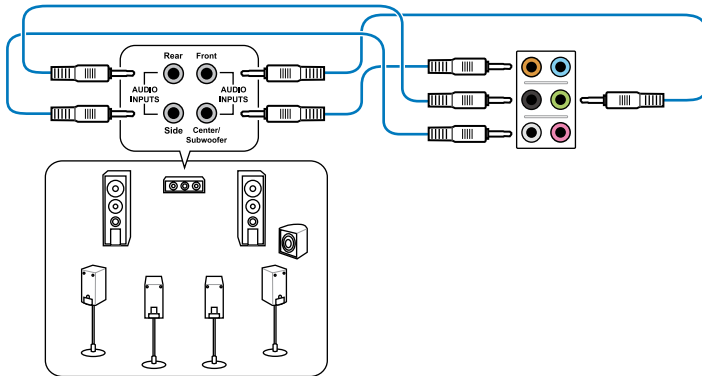

## 2.4 Starting up for the first time

1. After making all the connections, replace the system case cover.
2. Be sure that all switches are off.
3. Connect the power cord to the power connector at the back of the system chassis.
4. Connect the power cord to a power outlet that is equipped with a surge protector.
5. Turn on the devices in the following order:
  - a. Monitor
  - b. External SCSI devices (starting with the last device on the chain)
  - c. System power
6. After applying power, the system power LED on the system front panel case lights up. For systems with ATX power supplies, the system LED lights up when you press the ATX power button. If your monitor complies with the “green” standards or if it has a “power standby” feature, the monitor LED may light up or change from orange to green after the system LED turns on.

The system then runs the power-on self tests or POST. While the tests are running, the BIOS beeps (refer to the BIOS beep codes table below) or additional messages appear on the screen. If you do not see anything within 30 seconds from the time you turned on the power, the system may have failed a power-on test. Check the jumper settings and connections or call your retailer for assistance.

BIOS Beep	Description
One short beep	VGA detected Quick boot set to disabled No keyboard detected
One continuous beep followed by two short beeps then a pause (repeated)	No memory detected
One continuous beep followed by three short beeps	No VGA detected
One continuous beep followed by four short beeps	Hardware component failure

7. At power on, hold down the <Delete> key to enter the BIOS Setup. Follow the instructions in Chapter 3.

## 2.5 Turning off the computer

### 2.5.1 Using the OS shut down function

If you are using Windows® Vista™/ Windows® 7:

1. Click the **Start** button then select **Shut Down**.
2. The power supply should turn off after Windows® shuts down.

If you are using Windows® XP:

1. Click the **Start** button then select **Turn Off Computer**.
2. Click the **Turn Off** button to shut down the computer.
3. The power supply should turn off after Windows® shuts down.

### 2.5.2 Using the dual function power switch

While the system is ON, pressing the power switch for less than four seconds puts the system to sleep mode or to soft-off mode, depending on the BIOS setting.

Pressing the power switch for more than four seconds lets the system enter the soft-off mode regardless of the BIOS setting. Refer to section **3.6 Power Menu** in Chapter 3 for details.



This chapter tells how to change the system settings through the BIOS Setup menus. Detailed descriptions of the BIOS parameters are also provided.

# BIOS Setup **3**

3.1	Managing and updating your BIOS .....	3-1
3.2	BIOS Setup program.....	3-7
3.3	Extreme Tweaker menu .....	3-10
3.4	Main menu .....	3-16
3.5	Advanced menu .....	3-23
3.6	Power menu.....	3-34
3.7	Boot menu .....	3-40
3.8	Tools menu .....	3-44
3.9	Exit menu .....	3-49



## 3.1 Managing and updating your BIOS

The following utilities allow you to manage and update the motherboard Basic Input/Output System (BIOS) setup.

1. **ASUS Update** (Updates the BIOS in Windows® environment.)
2. **ASUS EZ Flash 2** (Updates the BIOS using a floppy disk or USB flash disk.)
3. **ASUS CrashFree BIOS 3 utility**: Restores the BIOS using the motherboard support DVD or a USB flash drive when the BIOS file fails or gets corrupted.

Refer to the corresponding sections for details on these utilities.



---

Save a copy of the original motherboard BIOS file to a USB flash drive in case you need to restore the BIOS in the future. Copy the original motherboard BIOS using the **ASUS Update** utility.

---

### 3.1.1 ASUS Update utility

The ASUS Update is a utility that allows you to manage, save, and update the motherboard BIOS in Windows® environment. The ASUS Update utility allows you to:

- Update the BIOS directly from the Internet
- Download the latest BIOS file from the Internet
- Update the BIOS from an updated BIOS file
- Save the current BIOS file
- View the BIOS version information

This utility is available in the support DVD that comes with the motherboard package.



---

ASUS Update requires an Internet connection either through a network or an Internet Service Provider (ISP).

---

### Launching ASUS Update

After installing AI Suite II from the motherboard support DVD, launch ASUS Update by clicking **Update > ASUS Update** on the AI Suite II main menu bar.



---

Quit all Windows® applications before you update the BIOS using this utility.

---

## Updating the BIOS through the Internet

To update the BIOS through the Internet:

1. From the ASUS Update screen, select **Update BIOS from Internet**, and then click **Next**.
2. Select the ASUS FTP site nearest you to avoid network traffic.  
  
If you want to enable the BIOS downgradable function and auto BIOS backup function, check the checkboxes before the two items on the screen.
3. Select the BIOS version that you want to download. Click **Next**.
4. You can decide whether to change the BIOS boot logo, which is the image appearing on screen during the Power-On Self-Tests (POST). Click **Yes** if you want to change the boot logo or **No** to continue.

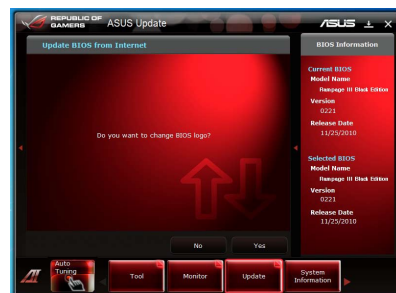

5. Click Browse to locate your desired picture file.



6. Adjust the picture resolution if needed and click **Next** to continue.



7. Follow the onscreen instructions to complete the update process.

## Updating the BIOS through a BIOS file

To update the BIOS through a BIOS file:

1. From the ASUS Update screen, select **Update BIOS from file**, and then click **Next**.



2. Locate the BIOS file from the Open window, click **Open**, and click **Next**.

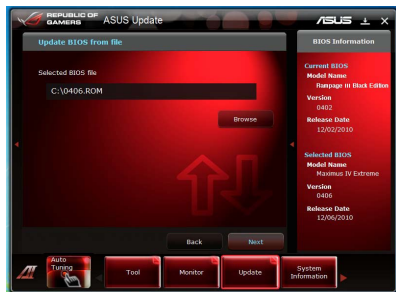

3. You can decide whether to change the BIOS boot logo. Click **Yes** if you want to change the boot logo or **No** to continue.
4. Follow the onscreen instructions to complete the update process.

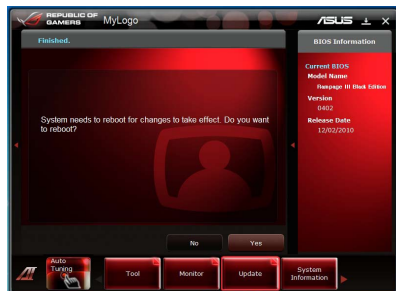

- The screenshots in this section are for reference only. The actual BIOS information vary by models.
- Refer to the software manual in the support DVD or visit the ASUS website at [www.asus.com](http://www.asus.com) for detailed software configuration.

### 3.1.2 ASUS EZ Flash 2 utility

The ASUS EZ Flash 2 feature allows you to update the BIOS without having to use a DOS-based utility. The EZ Flash 2 utility is built in the BIOS chip so it is accessible by pressing <Alt> + <F2> during the Power-On Self Tests (POST).



Before you start using this utility, download the latest BIOS from the ASUS website at [www.asus.com](http://www.asus.com).

To update the BIOS using EZ Flash 2

1. Insert the USB flash disk that contains the latest BIOS file to the USB port, and then launch EZ Flash 2 in any of these two ways:
  - Press <Alt> + <F2> during POST to display the following.
  - Enter the BIOS Setup program. Go to the **Tools** menu to select **EZ Flash 2** and press <Enter> to enable it.

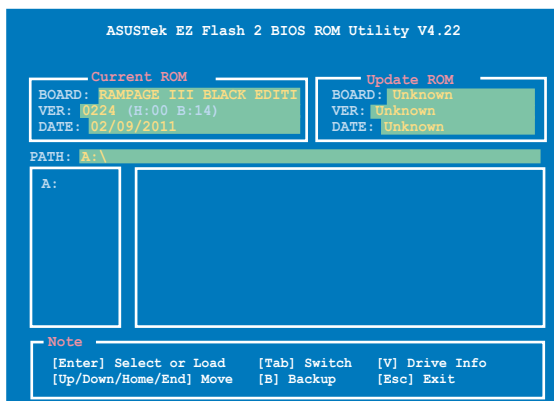

2. Press <Tab> to switch between drives until the correct BIOS file is found. When found, EZ Flash 2 performs the BIOS update process and automatically reboots the system when done.



- This function can support devices such as a USB flash disk with FAT 32/16 format and single partition only.
- DO NOT shut down or reset the system while updating the BIOS to prevent system boot failure!



Ensure to load the BIOS default settings to ensure system compatibility and stability. Select the **Load Setup Defaults** item under the **Exit** menu. See section **3.9 Exit Menu** for details.

### 3.1.3 ASUS CrashFree BIOS 3 utility

The ASUS CrashFree BIOS 3 utility is an auto recovery tool that allows you to restore the BIOS file when it fails or gets corrupted during the updating process. You can restore a corrupted BIOS file using the motherboard support DVD or a USB flash drive that contains the BIOS file.



---

The BIOS file in the motherboard support DVD may be older than the BIOS file published on the ASUS official website. If you want to use the newer BIOS file, download the file at [support.asus.com](http://support.asus.com) and save it to a USB flash drive.

---

### Recovering the BIOS

To recover the BIOS

1. Turn on the system.
2. Insert the motherboard support DVD to the optical drive, or the USB flash drive containing the BIOS file to the USB port.
3. The utility automatically checks the devices for the BIOS file. When found, the utility reads the BIOS file and starts flashing the corrupted BIOS file.
4. Turn off the system after the utility completes the updating process and power on again.
5. The system requires you to enter BIOS Setup to recover BIOS setting. To ensure system compatibility and stability, we recommend that you press <F2> to load default BIOS values.



---

DO NOT shut down or reset the system while recovering the BIOS! Doing so can cause system boot failure!

---

## 3.2 BIOS Setup program

This motherboard supports two programmable firmware chips that you can update using the provided utility described in section **3.1 Managing and updating your BIOS**.

Use the BIOS Setup program when you are installing a motherboard, reconfiguring your system, or prompted to “Run Setup.” This section explains how to configure your system using this utility.

Even if you are not prompted to use the Setup program, you can change the configuration of your computer in the future. For example, you can enable the security password feature or change the power management settings. This requires you to reconfigure your system using the BIOS Setup program so that the computer can recognize these changes and record them in the CMOS RAM of the firmware chip.

The firmware chip on the motherboard stores the Setup utility. When you start up the computer, the system provides you with the opportunity to run this program. Press <Del> during the Power-On Self-Test (POST) to enter the Setup utility; otherwise, POST continues with its test routines.

If you wish to enter Setup after POST, restart the system by pressing <Ctrl+Alt+Delete>, or by pressing the reset button on the system chassis. You can also restart by turning the system off and then back on. Do this last option only if the first two failed.

The Setup program is designed to make it as easy to use as possible. Being a menu-driven program, it lets you scroll through the various sub-menus and make your selections from the available options using the navigation keys.



- 
- The default BIOS settings for this motherboard apply for most conditions to ensure optimum performance. If the system becomes unstable after changing any BIOS settings, load the default settings to ensure system compatibility and stability. Select the **Load Setup Defaults** item under the Exit Menu. See section **3.9 Exit Menu**.
  - The BIOS Setup screens shown in this section are for reference purposes only, and may not exactly match what you see on your screen.
  - Visit the ASUS website at [www.asus.com](http://www.asus.com) to download the latest BIOS file for this motherboard.
-

### 3.2.1 BIOS menu screen

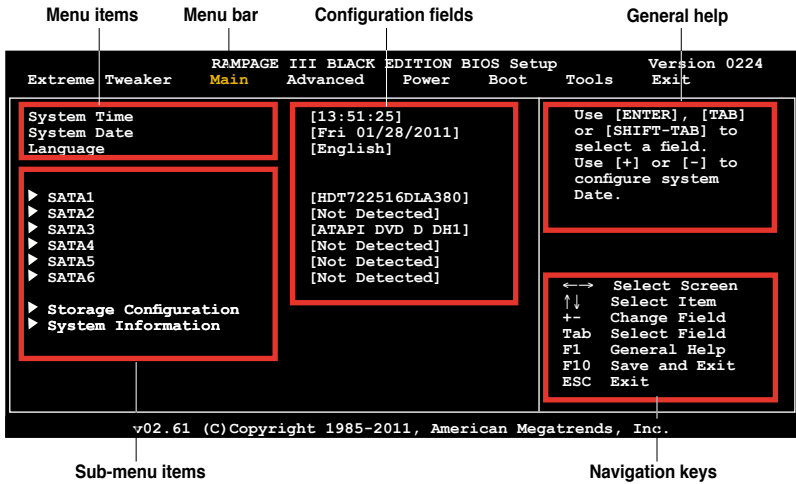

### 3.2.2 Menu bar

The menu bar on top of the screen has the following main items:

<b>Extreme Tweaker</b>	For changing the overclocking settings
<b>Main</b>	For changing the basic system configuration
<b>Advanced</b>	For changing the advanced system settings
<b>Power</b>	For changing the advanced power management (APM) configuration
<b>Boot</b>	For changing the system boot configuration
<b>Tools</b>	For configuring options for special functions
<b>Exit</b>	For selecting the exit options and loading default settings

### 3.2.3 Navigation keys

At the bottom right corner of a menu screen are the navigation keys for that particular menu. Use the navigation keys to select items in the menu and change the settings.



Some of the navigation keys differ from one screen to another.



### 3.2.4 Menu items

The highlighted item on the menu bar displays the specific items for that menu. For example, selecting Main shows the Main menu items.

The other items (Advanced, Power, Boot, and Exit) on the menu bar have their respective menu items.

### 3.2.5 Submenu items

A solid triangle before each item on any menu screen means that the item has a submenu. To display the submenu, select the item and press <Enter>.

### 3.2.6 Configuration fields

These fields show the values for the menu items. If an item is user-configurable, you can change the value of the field opposite the item. You cannot select an item that is not user-configurable.

A configurable field is enclosed in brackets, and is highlighted when selected. To change the value of a field, select it then press <Enter> to display a list of options. Refer to **3.2.7 Pop-up window**.

### 3.2.7 Pop-up window

Select a menu item then press <Enter> to display a pop-up window with the configuration options for that item.

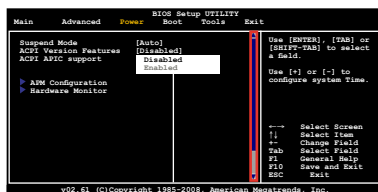

Pop-up window  
Scroll bar

### 3.2.8 Scroll bar

A scroll bar appears on the right side of a menu screen when there are items that do not fit on the screen. Press the Up/Down arrow keys or <Page Up> / <Page Down> keys to display the other items on the screen.

### 3.2.9 General help

At the top right corner of the menu screen is a brief description of the selected item.

### 3.3 Extreme Tweaker menu

The Extreme Tweaker menu items allow you to configure overclocking-related items.



Take caution when changing the settings of the **Extreme Tweaker** menu items. Incorrect field values can cause the system to malfunction.



The default values of the following items vary depending on the CPU and memory modules you install on the motherboard.

```
RAMPAGE III BLACK EDITION BIOS Setup Version 0224
Extreme Tweaker Main Advanced Power Boot Tools Exit

Configure System Performance Settings GPU.DIMM Post
Target CPU Frequency: 2793MHZ
Target DRAM Frequency: 1066MHZ
LN2 Mode: Disabled
QPI Loadline Calibration: Disabled
▶ GPU.DIMM Post

CPU Level Up [Auto]
-----
Ai Overclock Tuner [Auto]
CPU Ratio Status: (Min:12, Max:63)
CPU Ratio Setting [Auto]
CPU Turbo Power Limit [Disabled]
▶ CPU Configuration
DRAM Frequency [Auto]
UCLK Frequency [Auto]
QPI Link Data Rate [Auto]

Memory Recheck [Disabled]

←→ Select Screen
↑↓ Select Item
+- Change Field
F1 General Help
F10 Save and Exit
ESC Exit

v02.61 (C) Copyright 1985-2011, American Megatrends, Inc.
```

Scroll down to display the following items:

```
Memory Configuration Protect [Disabled]
▶ DRAM Timing Control

----- QPI/PCIE Tuning -----
CPU QPI Strength [Auto]
ALT QPI Strength [Auto]
Frist 2 Slots PCIE Strength [Auto]
Last 2 Slots PCIE Strength [Auto]
-----
CPU Differential Amplitude [Auto]
CPU Clock Skew [Auto]
IOH Clock Skew [Auto]
----- Extreme Engine Digi+ -----
DIGI+ VRM Duty Control [T.Probe]
PWM Volt. Control [Auto]
Load-Line Calibration [Auto]
CPU Voltage OCP [130%]
CPU PWM Frequency [Auto]
Phase Control [Extreme]
--- Please key in numbers or select voltage!-----
Extreme OV [Disabled]
Extreme OC [Auto]
CPU temp.: 53'C/127'F
CPU Voltage 1.230 [Auto]
CPU PLL Voltage 1.812 [Auto]
QPI/DRAM Core Voltage 1.151 [Auto]
DRAM Bus Voltage 1.651 [Auto]
▶ DRAM REF Voltages
IOH Voltage 1.111 [Auto]
IOH PCIE Voltage 1.508 [Auto]
ICH Voltage 1.111 [Auto]
ICH PCIE Voltage [Auto]

----- O.C. Profile -----
▶ ASUS O.C. Profile
----- Spread Spectrum Control-----
CPU Spread Spectrum [Auto]
PCIE Spread Spectrum [Auto]

←→ Select Screen
↑↓ Select Item
+- Change Option
F1 General Help
F10 Save and Exit
ESC Exit

v02.61 (C) Copyright 1985-2011, American Megatrends, Inc.
```

### 3.3.1 GPU.DIMM Post

Displays your installed GPU and DIMM status.

### 3.3.2 CPU Level Up [Auto]

Allows you to select a CPU level, and the related parameters will be automatically adjusted according to the selected CPU level. **Ai Overclock Tuner** is changed to [CPU Level Up] after you select a CPU level other than [Auto].

### 3.3.3 Ai Overclock Tuner [Auto]

Allows selection of CPU overclocking options to achieve desired CPU internal frequency. Select either one of the preset overclocking configuration options:

<b>Manual</b>	Allows you to individually set overclocking parameters.
<b>Auto</b>	Loads the optimal settings for the system.
<b>X.M.P.</b>	If you install memory module(s) supporting the eXtreme Memory Profile (X.M.P.) Technology, choose this item to set the profile(s) supported by your memory module(s) for optimizing the system performance.
<b>CPU Level Up</b>	Allows you to select a CPU level, and the related parameters will be adjusted automatically.

### OC From CPU Level Up [Auto]

This item appears only when you set the **Ai Overclock Tuner** item to [Manual] and allows you to select a desired CPU level supported by your installed CPU. Other relevant parameters will be adjusted automatically according to your selection.

### eXtreme Memory Profile [Disabled]

This item appears only when you set the **Ai Overclock Tuner** item to [X.M.P.] and allows you to select the X.M.P. mode supported by your memory module. Configuration options: [Disabled] [High Performance] [High Frequency]

### 3.3.4 CPU Ratio Setting [Auto]

Allows you to adjust the ratio between CPU Core Clock and FSB Frequency. Use the <+> and <-> keys to adjust the value.

### 3.3.5 CPU Turbo Power Limit [Disabled]

Allows you to activate or deactivate the CPU Turbo Power Limit. If you want to keep the Turbo mode ratio, remember to disable C1E and TM functions at the same time. Configuration options: [Disabled] [Enabled]

### 3.3.6 CPU Configuration

The items in this menu show the CPU-related information that the BIOS automatically detects. Refer to **3.5 Advanced menu** for details.



---

The following three items appear when you set the **Ai Overclock Tuner** item to [X.M.P] or [Manual].

---

#### 3.3.7 BCLK Frequency [XXX]

Allows you to adjust the Internal Base Clock (BCLK). Use the <+> and <-> keys to adjust the value. You can also type the desired value using the numeric keypad. The values range from 100 to 500.

#### 3.3.8 BCLK Enhance [Auto]

Allows you to enhance the Internal Base Clock (BCLK) overclocking.  
Configuration options: [Auto] [Typical Sweet Spot] [Normal] [Sweet Spot +1] [Normal] [Sweet Spot +2] [Normal] [Sweet Spot +3] [Normal] [Sweet Spot +4] [Normal] [Sweet Spot +5] [Normal] [Sweet Spot -1] [Sweet Spot -2] [Sweet Spot -3] [Sweet Spot -4] [Sweet Spot -5] [Sweet Spot -6] [Sweet Spot -7] [Sweet Spot -8]

#### 3.3.9 PCIE Frequency [XXX]

Allows you to adjust the PCI Express frequency. Use the <+> and <-> keys to adjust the value. You can also type the desired value using the numeric keypad. The values range from 100 to 200.

#### 3.3.10 DRAM Frequency [Auto]

Allows you to set the DDR3 operating frequency.  
Configuration options: [Auto] [DDR3-800MHz] [DDR3-1066MHz] [DDR3-1333MHz] [DDR3-1600MHz] [DDR3-1866MHz] [DDR3-2133MHz] [DDR3-2400MHz]



---

For CPU that is locked, only frequency [DDR3-800MHz] or [DDR3-1066MHz] can work.

---

#### 3.3.11 UCLK Frequency [Auto]

Allows you to adjust the Uncore Clock Ratio.

#### 3.3.12 QPI Link Data Rate [Auto]

Allows you to adjust the QPI link data rate.  
Configuration options: [Auto] [Slow Mode] [4800MT/s] [5866MT/s] [6400MT/s]

#### 3.3.13 Memory Recheck [Disabled]

Memory Recheck helps fix the “DRAM not found” error  
Configuration options: [Disabled] [Enabled]

### 3.3.14 Memory Configuration Protect [Disabled]

Allows you to lock or unlock the memory configuration.

Configuration options: [Enabled] [Disabled]

### 3.3.15 DRAM Timing Control

The sub-items in this menu allow you to set the DRAM timing control features. Use the <+> and <-> keys to adjust the value. To restore the default setting, type [auto] using the keyboard and press the <Enter> key.



---

Changing the values in this menu may cause the system to become unstable! If this happens, revert to the default settings.

---

### 3.3.16 CPU QPI Strength [Auto]

Allows you to select the CPU QPI strength.

Configuration options: [Auto] [Typical Sweet Spot] [Normal] [Weaker]

### 3.3.17 ALT QPI Strength [Auto]

Allows you to select the ALT QPI strength.

Configuration options: [Auto] [Typical Sweet Spot] [Normal] [Weaker]

### 3.3.18 First 2 Slots PCIe Strength [Auto]

Allows you to set the first two slots PCIe strength. The values range from 0.80825V to 1.51050V with a 0.01325V interval.

### 3.3.19 Last 2 Slots PCIe Strength [Auto]

Allows you to set the last two slots PCIe strength. The values range from 0.80825V to 1.51050V with a 0.01325V interval.

### 3.3.20 CPU Differential Amplitude [Auto]

Different AMP might enhance BCLK overclocking ability.

Configuration options: [Auto] [700mV] [800mV] [900mV] [1000mV]

### 3.3.21 CPU Clock Skew [Auto]

Adjusting this item may help enhancing BCLK overclocking ability. You may need to adjust the IOH Clock Skew item at the same time.

Configuration options: [Auto] [Normal] [Delay 100ps]–[Delay 1500ps]

### 3.3.22 IOH Clock Skew [Auto]

Adjusting this item may help enhancing BCLK overclocking ability. You may need to adjust the CPU Clock Skew item at the same time.

Configuration options: [Auto] [Normal] [Delay 100ps]–[Delay 1500ps]

### 3.3.23 Digi+ VRM Duty Control [T.Probe]

[T.Probe] Manages to achieve the optimum thermal performance for longer component life.

[Extreme] Unleashes the power system to push the limit for extreme overclocking.

### 3.3.24 PWM Volt. Control [Auto]

Allows you to adjust the MOSFET driving voltage.

Configuration options: [Auto] [6V] [7V] [8V] [9V] [10V]

### 3.3.25 Load-Line Calibration [Auto]

Allows you to select the CPU Load-Line mode.

Configuration options: [Auto] [0% Calibration] [50% Calibration] [100% Calibration]

### 3.3.26 CPU Voltage OCP [Enabled]

Configuration options: [130%] [160%] [200%]

### 3.3.27 CPU PWM Frequency [Auto]

Configuration options: [Auto] [250KHz] [300KHz]—[900KHz] [950KHz] [1MHz]

### 3.3.28 Phase Control [Extreme]

[Standard] Standard power saving.

[Extreme] Enables and maintains the active full stage phase array.

### 3.3.29 Extreme OV [Disabled]

[Enabled] Enables the Extreme OV function.

[Disabled] Disables this function.

### 3.3.30 Extreme OC [Auto]

Configuration options: [Auto] [Mode 1] [Mode 2]

### 3.3.31 CPU Voltage [Auto]

Allows you to set the CPU voltage. The values range from 0.85000V to 2.30000V with a 0.00625V interval.



---

Refer to the CPU documentation before setting the CPU VCore voltage. Setting a high VCore voltage may damage the CPU permanently, and setting a low VCore voltage may make the system unstable.

---

### 3.3.32 CPU PLL Voltage [Auto]

Allows you to set the CPU PLL voltage. The values range from 1.20575V to 2.05375V with a 0.01325V interval.

### **3.3.33 QPI/DRAM Core Voltage [Auto]**

Allows you to set the QPI/DRAM core voltage. The values range from 1.20000V to 2.50000V with a 0.00625V interval.

### **3.3.34 DRAM Bus Voltage [Auto]**

Allows you to set the DRAM voltage. The values range from 1.20575V to 2.50425V with a 1.01325V interval.

### **3.3.35 DRAM REF Voltages**

#### **DRAM DATA REF Voltage on CHA/B/C [Auto]**

Allows you to set the DRAM DATA Reference Voltage on Channel A/B/C. The values range from -157.5mV to +200mV with a 12.5mV interval. Different ratio might enhance DRAM overclocking ability.

#### **DRAM CTRL REF Voltage on CHA/B/C [Auto]**

Allows you to set the DRAM CTRL Reference Voltage on Channel A/B/C. The values range from -157.5mV to +200mV with a 12.5mV interval. Different ratio might enhance DRAM overclocking ability.

### **3.3.36 IOH Voltage [Auto]**

Allows you to set the IOH voltage. The values range from 1.11300V to 2.19950V with a 0.01325V interval.

### **3.3.37 IOH PCIE Voltage [Auto]**

Allows you to set the IOH voltage. The values range from 1.51050V to 2.78250V with a 0.01325V interval.

### **3.3.38 ICH Voltage [Auto]**

Allows you to set the ICH voltage. The values range from 1.11300V to 2.00075V with a 0.01325V interval.

### **3.3.39 ICH PCIE Voltage [Auto]**

Allows you to set the ICH PCIE voltage. The values range from 1.51050V to 2.05375V with a 0.01325V interval.

### **3.3.40 ASUS O.C. Profile**

Allows you to store or load different BIOS settings. Refer to **3.8.2 ASUS O.C. Profile** for details.

### **3.3.41 CPU Spread Spectrum [Auto]**

- [Auto] Automatic configuration.
- [Disabled] Enhances the BCLK overclocking ability.
- [Enabled] Sets to [Enabled] for EMI control.

### **3.3.42 PCIE Spread Spectrum [Auto]**

- [Auto] Automatic configuration.
- [Disabled] Enhances the PCIE overclocking ability.
- [Enabled] Sets to [Enabled] for EMI control.



## 3.4 Main menu

When you enter the BIOS Setup program, the Main menu screen appears, giving you an overview of the basic system information.



Refer to section 3.2.1 **BIOS menu screen** for information on the menu screen items and how to navigate through them.

```
RAMPAGE III BLACK EDITION BIOS Setup          Version 0224
Extreme Tweaker      Main      Advanced      Power      Boot      Tools      Exit

System Time                [13:51:25]
System Date                [Mon 01/31/2011]
Language                   [English]

▶ SATA1                    [HDT722516DLA380]
▶ SATA2                    [Not Detected]
▶ SATA3                    [ATAPI DVD D DH1]
▶ SATA4                    [Not Detected]
▶ SATA5                    [Not Detected]
▶ SATA6                    [Not Detected]

▶ Storage Configuration
▶ System Information

Use [ENTER], [TAB]
or [SHIFT-TAB] to
select a field.

Use [+] or [-] to
configure system Time.

←→ Select Screen
↑↓ Select Item
+- Change Field
F1 General Help
F10 Save and Exit
ESC Exit

v02.61 (C) Copyright 1985-2011, American Megatrends, Inc.
```

### 3.4.1 System Time [xx:xx:xx]

Allows you to set the system time.

### 3.4.2 System Date [Day xx/xx/xxxx]

Allows you to set the system date.

### 3.4.3 Language [English]

Allows you to choose the BIOS language version from the options.

Configuration options: [繁體中文] [簡體中文] [日本語] [Français] [Deutsch] [English]

### 3.4.4 SATA 1-6

While entering Setup, the BIOS automatically detects the presence of Serial ATA devices. There is a separate sub-menu for each SATA device. Select a device item then press <Enter> to display the SATA device information.

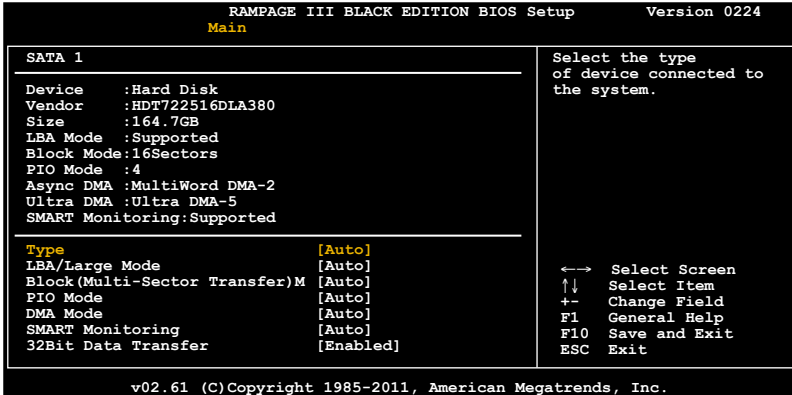

The BIOS automatically detects the values opposite the dimmed items (Device, Vendor, Size, LBA Mode, Block Mode, PIO Mode, Async DMA, Ultra DMA, and SMART monitoring). These values are not user-configurable. These items show [Auto] if no IDE device is installed in the system.

#### Type [Auto]

Allows you to select the type of IDE drive installed.

[Not Installed] Select this option if no IDE drive is installed.

[Auto] Allows automatic selection of the appropriate IDE device type.

[CDROM] Select this option if you are specifically configuring a CD-ROM drive.

[ARMD] Select [ARMD] (ATAPI Removable Media Device) if your device is either a ZIP, LS-120, or MO drive.

#### LBA/Large Mode [Auto]

Enables or disables the LBA (Logical Block Addressing) mode.

[Auto] Select [Auto] to enable the LBA mode (Logical Block Addressing mode) if the device supports this mode, and if the device was not previously formatted with LBA mode disabled.

[Disabled] Disable this function.

### **Block (Multi-Sector Transfer) M [Auto]**

Enables or disables data multi-sectors transfers.

[Auto] When set to [Auto], the data transfer from and to the device occurs multiple sectors at a time if the device supports multi-sector transfer feature.

[Disabled] When set to [Disabled], the data transfer from and to the device occurs one sector at a time.

### **PIO Mode [Auto]**

[Auto] Allows automatic selection of the PIO (Programmed input/output) modes, which correspond to different data transfer rates.

[0] [1] – [4] Set the PIO mode to Mode 0, 1, 2, 3, or 4.

### **DMA Mode [Auto]**

DMA (Direct Memory Access) allows your computer to transfer data to and from the hardware devices installed with much less CPU overhead.

The DMA mode consists of SDMA (single-word DMA), MDMA (multi-word DMA), and UDMA (Ultra DMA). Setting to [Auto] allows automatic selection of the DMA mode, or you can select from the following options: [SWDMA0]

[SWDMA1] [SWDMA2] [MWDMA0] [MWDMA1] [MWDMA2] [UDMA0] [UDMA1] [UDMA2] [UDMA3] [UDMA4] [UDMA5]

### **SMART Monitoring [Auto]**

[Auto] Allows automatic selection of the S.M.A.R.T (Smart Monitoring, Analysis, and Reporting Technology).

[Enabled] Enable the S.M.A.R.T feature.

[Disabled] Disable the S.M.A.R.T feature.

### **32Bit Data Transfer [Enabled]**

[Enabled] Sets the IDE controller to combine two 16-bit reads from the hard disk into a single 32-bit double word transfer to the processor. This makes more efficient use of the PCI bus as fewer transactions are needed for the transfer of a particular amount of data.

[Disabled] Disable this function.

### 3.4.5 Storage Configuration

The items in this menu allow you to set or change the configurations for the SATA devices installed in the system. Select an item then press <Enter> if you want to configure the item.

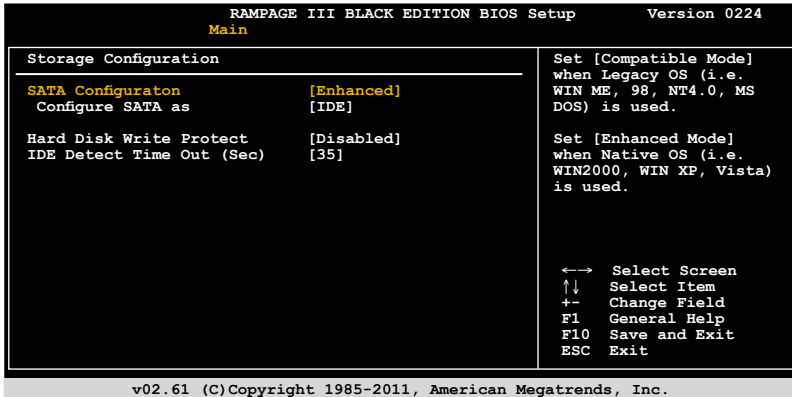

#### SATA Configuration [Enhanced]

Configuration options: [Disabled] [Compatible] [Enhanced]

##### Configure SATA as [IDE]

Sets the configuration for the Serial ATA connectors supported by the Southbridge chip. Configuration options: [IDE] [RAID] [AHCI]



- If you want to use the Serial ATA hard disk drives as Parallel ATA physical storage devices, keep the default setting [IDE].
- If you want the Serial ATA hard disk drives to use the Advanced Host Controller Interface (AHCI), set this item to [AHCI]. The AHCI allows the onboard storage driver to enable advanced Serial ATA features that increases storage performance on random workloads by allowing the drive to internally optimize the order of commands.
- If you want to create a RAID 0, RAID 1, RAID 5, RAID 10, or the Intel® Rapid Storage Technology configuration from the Serial ATA hard disk drives, set this item to [RAID].

#### Hard Disk Write Protect [Disabled]

Disables or enables device write protection. This will be effective only if the device is accessed through BIOS. Configuration option: [Disabled] [Enabled]

#### IDE Detect Time Out (Sec) [35]

Selects the time out value for detecting ATA/ATAPI devices. Configuration options: [0] [5] [10] [15] [20] [25] [30] [35]

### 3.4.6 AHCI Configuration

This menu is the section for AHCI configuration. It appears only when you set the item **Configure SATA** as from the sub-menu of **SATA Configuration** to [AHCI].

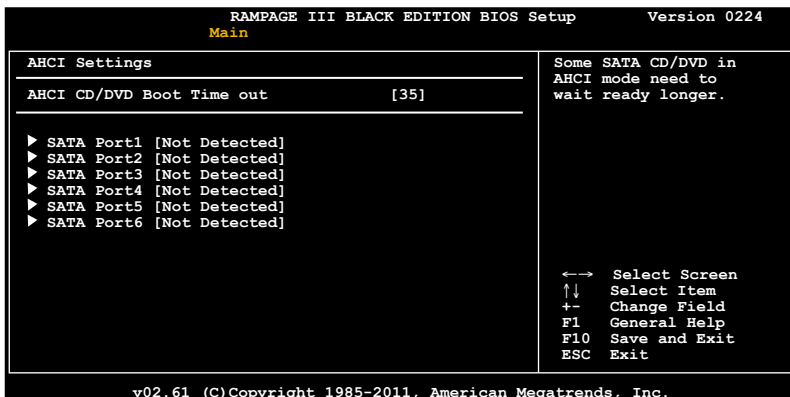

#### AHCI CD/DVD Boot Time Out [35]

Selects the time out value for the booting time of SATA CD/DVD devices.

Configuration options: [0] [5] [10] [15] [20] [25] [30] [35]

#### SATA Port1-6 [XXXX]

Displays the status of auto-detection of SATA devices.

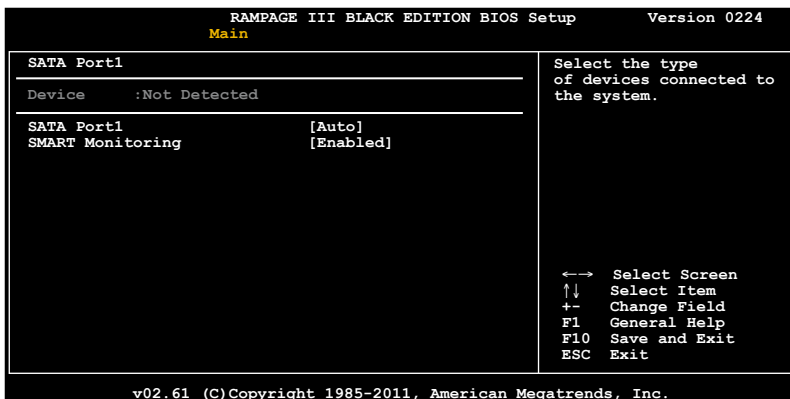

#### SATA Port1 [Auto]

Allows you to select the type of device connected to the system.

Configuration options: [Auto] [Not Installed]

#### SMART Monitoring [Enabled]

Allows you to set the Self-Monitoring, Analysis and Reporting Technology.

Configuration options: [Disabled] [Enabled]

### 3.4.7 System Information

This menu gives you an overview of the general system specifications. The BIOS automatically detects the items in this menu.

```
RAMPAGE III BLACK EDITION BIOS Setup          Version 0224
Main

BIOS Information
Version      : 0224
Build Date  : 02/09/11

Processor
Type       : Genuine Intel(R) CPU 000 @ 3.20GHz
Speed     : 3200MHz

System Memory
Usable Size : 1016MB

BIOS Status
Now BIOS status : BIOS1

←→ Select Screen
↑↓ Select Item
+- Change Field
F1  General Help
F10 Save and Exit
ESC Exit

v02.61 (C)Copyright 1985-2011, American Megatrends, Inc.
```

## 3.5 Advanced menu

The Advanced menu items allow you to change the settings for the CPU and other system devices.

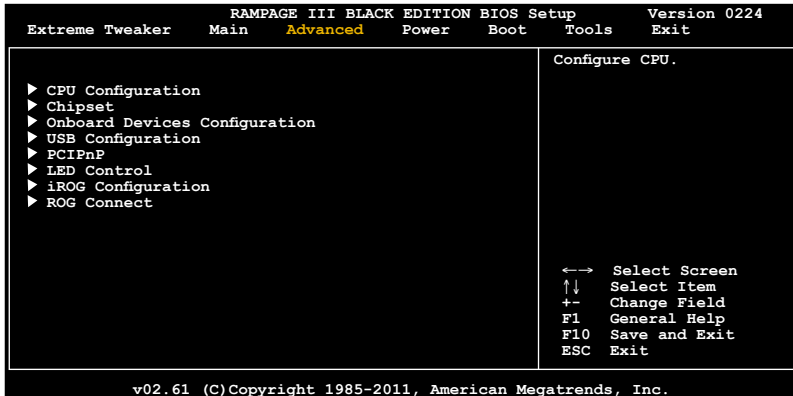

### 3.5.1 CPU Configuration

The items in this menu show the CPU-related information that the BIOS automatically detects.



The items shown in this screen may be different due to the CPU you installed.

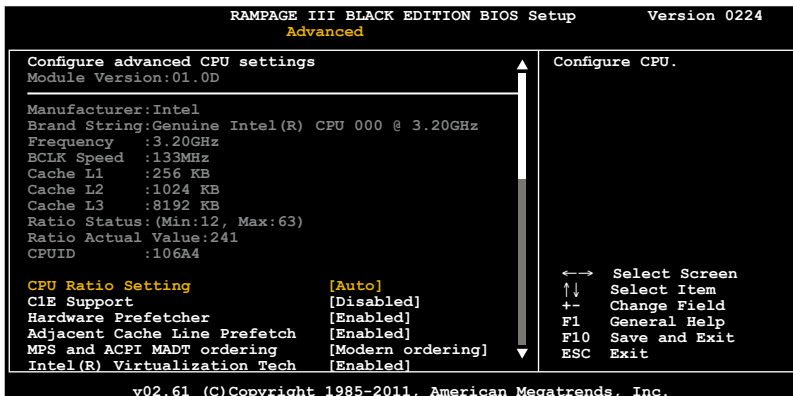

Scroll down to display the following items:



### **CPU Ratio Setting [Auto]**

Allows you to adjust the ratio between CPU Core Clock and BCLK Frequency. Use the <+> and <-> keys to adjust the value. The valid value ranges differently according to your CPU model.

### **C1E Support [Disabled]**

[Enabled] Enables the C1E support function. This item should be enabled in order to enable the Enhanced Halt State.

[Disabled] Disables this function.

### **Hardware Prefetcher [Enabled]**

[Enabled] Enables the Hardware Prefetcher function. This item should be enabled in order to enable the L2 cache (MLC) Streamer Prefetcher for tuning performance of the specific application.

[Disabled] Disables this function.

### **Adjacent Cache Line Prefetcher [Enabled]**

[Enabled] Enables the Adjacent Cache Line Prefetcher function. This item should be enabled in order to enable the L2 cache (MLC) Spatial Prefetcher for tuning performance of the specific application.

[Disabled] Disables this function.

### **MPS and ACPI MADT ordering [Modern ordering]**

[Modern ordering] For Windows XP or later OSes.

[Legacy ordering] For Windows 2000 or earlier OSes.

### **Intel(R) Virtualization Tech [Enabled]**

[Enabled] Allows a hardware platform to run multiple operating systems separately and simultaneously, enabling one system to virtually function as several systems.

[Disabled] Disables this function.

### **CPU TM Function [Enabled]**

[Enabled] Enables the overheated CPU to throttle its clock speed to cool down.

[Disabled] Disables this function.

### **Execute-Disable Bit [Enabled]**

[Enabled] Enables the No-Execution Page Protection Technology.

[Disabled] Forces the XD feature flag to always return to zero (0).

### **Intel(R) HT Technology [Enabled]**

[Enabled] Enables the Intel Hyper-Threading Technology.

[Disabled] Only one thread per activated CPU core is enabled.



## Active Processor Cores [All]

- [All] Activate all CPU cores in the processor package.
- [1] Activate only 1 CPU core in the processor package.
- [2]–[5] Activate 2–5 CPU cores in the processor package.



---

The number of the CPU cores varies with your installed CPU.

---

## A20M [Disabled]

- [Enabled] Legacy OSES and APs may need this function enabled.
- [Disabled] Disables this function.

## Intel(R) SpeedStep (TM) Tech [Enabled]

- [Enabled] The CPU speed is controlled by the operating system.
- [Disabled] The CPU runs at its default speed.

## Intel(R) TurboMode Tech [Enabled]

This item appears only when you enable the **Intel(R) SpeedStep(TM) Tech** item.

- [Enabled] Allows processor cores to run faster than marked frequency in specific condition.
- [Disabled] Disables this function.

## Intel(R) C-STATE Tech [Disabled]

- [Enabled] Allows the CPU to save more power under idle mode. Enable this item only when you install a C-State Technology-supported CPU.
- [Disabled] Disables this function.

## C State package limit setting [Auto]

This item appears only when you set the **Intel(R) C-STATE Tech** item to [Enabled]. We recommend that you set this item to [Auto] for BIOS to automatically detect the C-State mode supported by your CPU. Configuration options: [Auto] [C1] [C3] [C6]

## C1 Auto Demotion [Enabled]

This item appears only when you set the **Intel(R) C-STATE Tech** item to [Enabled]. When C1 Auto Demotion is set to [Enabled], the CPU will conditionally demote C3/C6/C7 requests to C1 based on uncore auto-demote information. Configuration options: [Disabled] [Enabled]

## C3 Auto Demotion [Enabled]

This item appears only when you set the **Intel(R) C-STATE Tech** item to [Enabled]. When C3 Auto Demotion is set to [Enabled], the CPU will conditionally demote C6/C7 requests to C3 based on uncore auto-demote information. Configuration options: [Disabled] [Enabled]

## 3.5.2 Chipset

The Chipset menu allows you to change the advanced chipset settings. Select an item then press <Enter> to display the sub-menu.

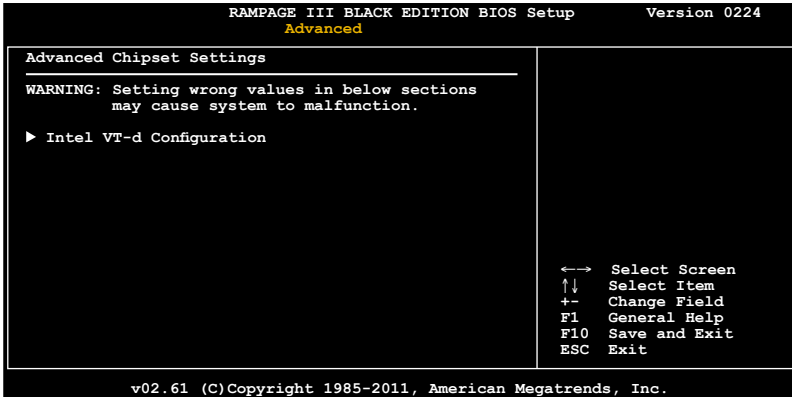

### Intel VT-d Configuration

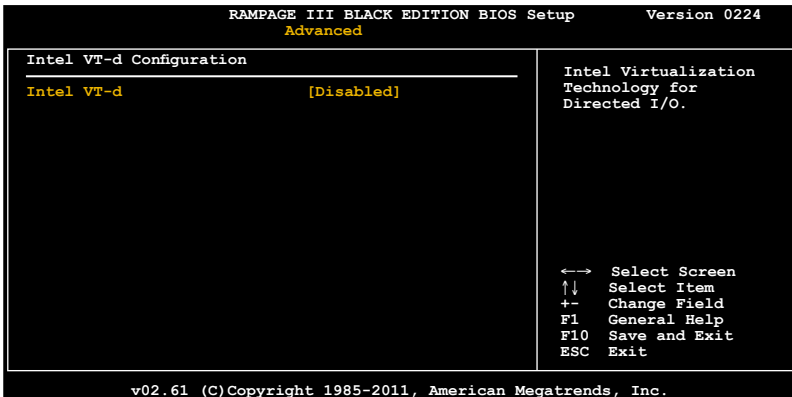

#### Intel VT-d [Disabled]

Enables or disables the Intel Virtualization technology for directed I/O.

### 3.5.3 Onboard Devices Configuration

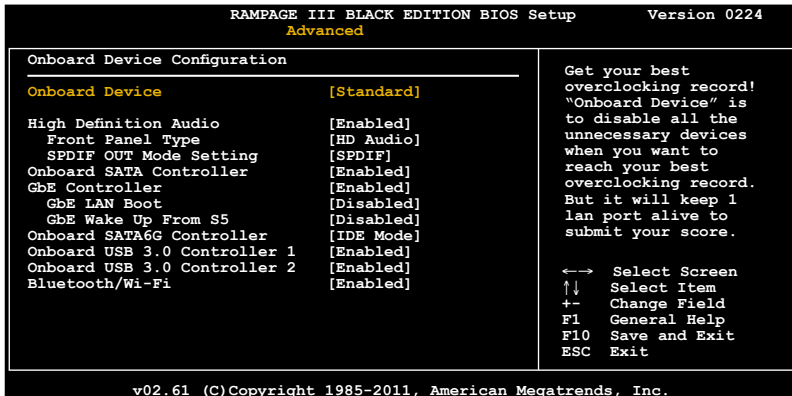

#### Onboard Device [Standard]

[Standard] Applies the standard settings.

[Disabled] Disables all the onboard devices.



The following items become unavailable when **Onboard Device** is set to [Disabled].

#### High Definition Audio [Enabled]

[Enabled] Enables the High Definition Audio Controller.

[Disabled] Disables the controller.

##### Front Panel Type [HD Audio]

[AC97] Set the front panel audio connector (AAFP) mode to legacy AC'97

[HD Audio] Set the front panel audio connector (AAFP) mode to high-definition audio.

##### SPDIF OUT Mode Setting [SPDIF]

[SPDIF] Set the SPDIF OUT mode to SPDIF.

[HDMI] Set the SPDIF OUT mode to HDMI.

#### Onboard SATA Controller [Enabled]

[Disabled] Disables the onboard SATA controller.

[Enabled] Enables the onboard SATA controller.

#### GbE Controller [Enabled]

[Enabled] Enables GbE LAN Controller.

[Disabled] Disables GbE LAN Controller.

GbE LAN Boot [Disabled]

This item appears only when you enable the previous item(s).

[Enabled] Enables GbE LAN Boot ROM.

[Disabled] Disables GbE LAN Boot ROM.

GbE Wake Up From S5 [Disabled]

This item appears only when you enable the previous item(s).

[Enabled] Enables GbE wake up from S5.

[Disabled] Disables GbE wake up from S5.

**Onboard SATA6G Controller [IDE Mode]**

[Disabled] Disables the onboard SATA6G controller.

[IDE Mode] Set to [IDE Mode] when you want to use the Serial ATA hard disk drives as Parallel ATA physical storage devices.

[AHCI Mode] Set to [AHCI Mode] when you want the SATA hard disk drives to use the AHCI (Advanced Host Controller Interface). The AHCI allows the onboard storage driver to enable advanced Serial ATA features that increases storage performance on random workloads by allowing the drive to internally optimize the order of commands.

**Onboard USB 3.0 Controller 1 [Enabled]**

[Enabled] Enables the onboard USB 3.0 Controller 1.

[Disabled] Disables the controller.

**Onboard USB 3.0 Controller 2 [Enabled]**

[Enabled] Enables the onboard USB 3.0 Controller 2.

[Disabled] Disables the controller.

**Bluetooth/Wi-Fi [Enabled]**

[Enabled] Enables the onboard Bluetooth/Wi-Fi module.

[Disabled] Disables the module.

## 3.5.4 USB Configuration

The items in this menu allows you to change the USB-related features. Select an item then press <Enter> to display the configuration options.

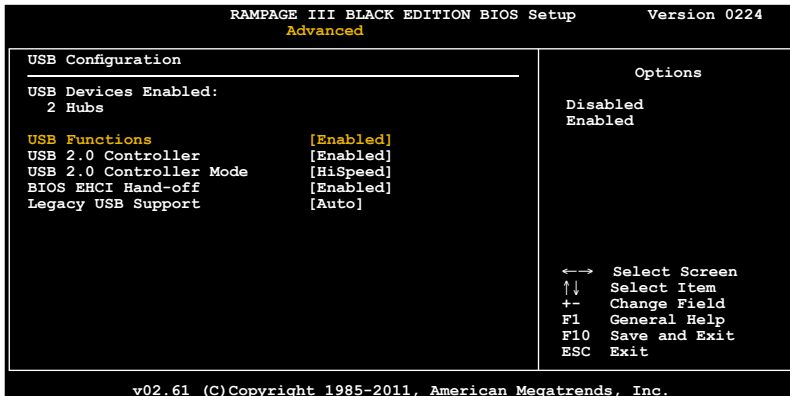

The **USB Devices Enabled** item shows the auto-detected values. If no USB device is detected, the item shows None.

### USB Functions [Enabled]

[Enabled] Enables the USB Host Controllers.

[Disabled] Disables the controllers.



The following items appear only when you set **USB Functions** to [Enabled].

### USB 2.0 Controller [Enabled]

[Enabled] Enables the USB 2.0 Controllers.

[Disabled] Disables the controllers.

### USB 2.0 Controller Mode [HiSpeed]

[FullSpeed] Sets the USB 2.0 Controller in full speed (12Mbps).

[HiSpeed] Sets the USB 2.0 Controller in high speed (480Mbps).

### BIOS EHCI Hand-off [Enabled]

[Enabled] Enables the support for operating systems without an EHCI hand-off feature.

[Disabled] Disables the function.

## Legacy USB Support [Auto]

- [Auto] Allows the system to detect the presence of USB devices at startup. If detected, the USB controller legacy mode is enabled. If no USB device is detected, the legacy USB support is disabled.
- [Enabled] Enables the support for USB devices on legacy operating systems (OS).
- [Disabled] Disables the function.

## 3.5.5 PCIPnP

The PCIPnP menu items allow you to change the advanced settings for PCI/PnP devices.



### Plug And Play O/S [No]

- [Yes] When set to [Yes] and if you install a Plug and Play operating system, the operating system configures the Plug and Play devices not required for boot.
- [No] When set to [No], BIOS configures all the devices in the system.

## 3.5.6 LED Control

The LED Control menu items allow you to change the advanced settings for the onboard LEDs.



Take caution when changing the settings of the LED Control menu items. Incorrect field values can cause the system to malfunction.

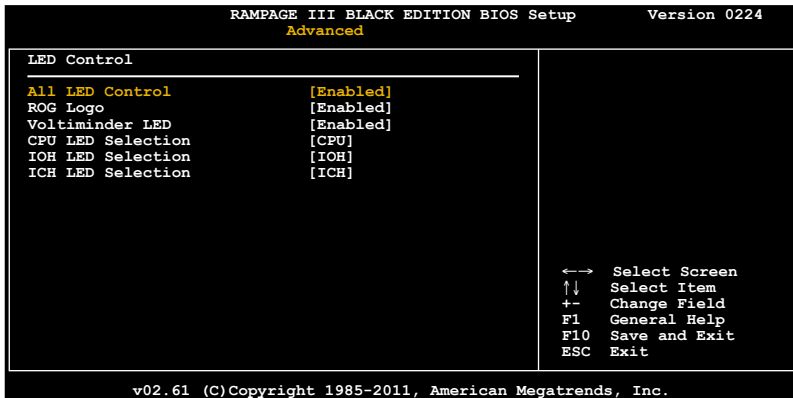

### All LED Control [Enabled]

Allows you to enable or disable the onboard LEDs control.

Configuration options: [Enabled] [Disabled]



The following items appear only when you set **All LED Control** to [Enabled].

### ROG Logo [Enabled]

Allows you to enable or disable the ROG Logo LED.

Configuration options: [Enabled] [Disabled]

### Voltiminder LED [Enabled]

Allows you to enable or disable the onboard Voltiminder LED.

Configuration options: [Enabled] [Disabled]

### CPU LED Selection [CPU]

Allows you to switch the onboard CPU LED display between CPU voltage [CPU], CPU PLL voltage [CPU PLL] and QPI/DRAM core voltage [QPI/DRAM Core].

Configuration options: [CPU] [CPU PLL] [QPI/DRAM Core]

### IOH LED Selection [IOH]

Allows you to switch the onboard IOH LED display between IOH voltage [IOH], and IOH PCIe voltage [IOH PCIe]. Configuration options: [IOH] [IOH PCIe]

### ICH LED Selection [ICH]

Allows you to switch the onboard ICH LED display between ICH voltage [ICH], and ICH PCIe voltage [ICH PCIe]. Configuration options: [ICH] [ICH PCIe]

## 3.5.7 iROG Configuration

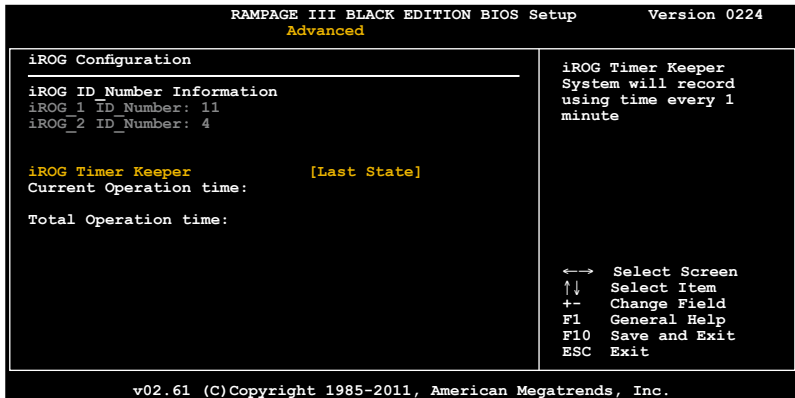

### iROG Timer Keeper [Last State]

Allows you to set the iROG Time Keeper operation mode. Configuration options: [Last State] [Disabled] [Enabled]



## 3.5.8 ROG Connect

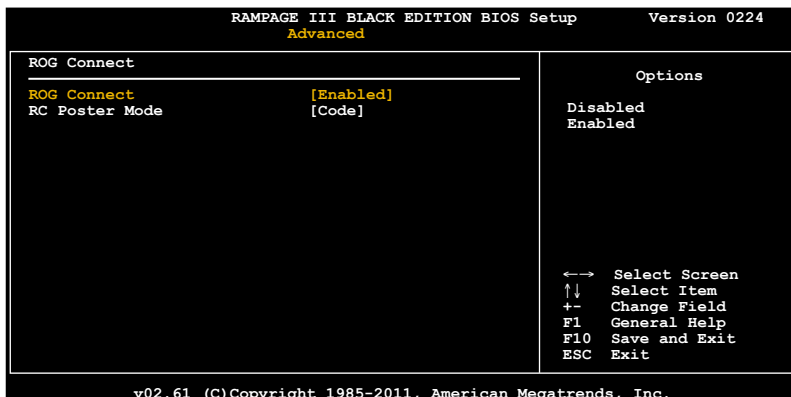

### ROG Connect [Enabled]

Allows you to enable or disable the ROG Connect function.

Configuration options: [Enabled] [Disabled]

### RC Poster Mode [Code]

RC Poster describes what occurs during the POST.

Configuration options: [String] [Code]

## 3.6 Power menu

The Power menu items allow you to change the settings for the Advanced Power Management (APM). Select an item then press <Enter> to display the configuration options.

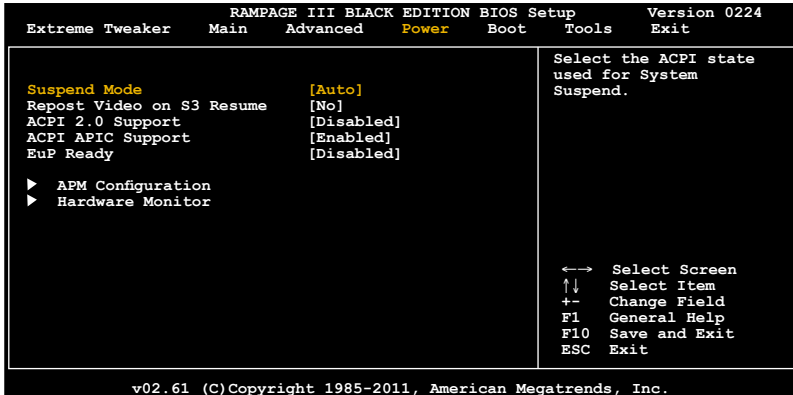

### 3.6.1 Suspend Mode [Auto]

Allows you to select the Advanced Configuration and Power Interface (ACPI) state to be used for system suspend.

[S1 (POS) only] Sets the ACPI suspend mode to S1/POS (Power On Suspend).

[S3 only] Sets the ACPI suspend mode to S3/STR (Suspend To RAM).

[Auto] The system automatically configures the ACPI suspend mode.

### 3.6.2 Repost Video on S3 Resume [No]

Determines whether to invoke VGA BIOS POST on S3/STR resume.

[No] When set to [No], the system will not invoke VGA BIOS POST on S3/STR resume.

[Yes] When set to [Yes], the system invokes VGA BIOS POST on S3/STR resume.

### 3.6.3 ACPI 2.0 Support [Disabled]

[Disabled] When set to [Disabled], the system will not add additional tables as per ACPI 2.0 specifications.

[Enabled] When set to [Enabled], the system adds additional tables as per ACPI 2.0 specifications.

### 3.6.4 ACPI APIC Support [Enabled]

Allows you to enable or disable the Advanced Configuration and Power Interface (ACPI) support in the Advanced Programmable Interrupt Controller (APIC).

[Disabled] When set to [Disabled], the system disable the Advanced Configuration and Power Interface (ACPI) support in the Advanced Programmable Interrupt Controller (APIC).

[Enabled] When set to [Enabled], the ACPI APIC table pointer is included in the RSDT pointer list.

### 3.6.5 EuP Ready [Disabled]

[Disabled] Disables the Energy Using Products (EuP) Ready function.

[Enabled] Allows BIOS to switch off some power at S5 state to get system ready for the EuP requirement. When set to [Enabled], power for WOL, WO\_USB, audio and onboard LEDs will be switched off at S5 state.

### 3.6.6 APM Configuration

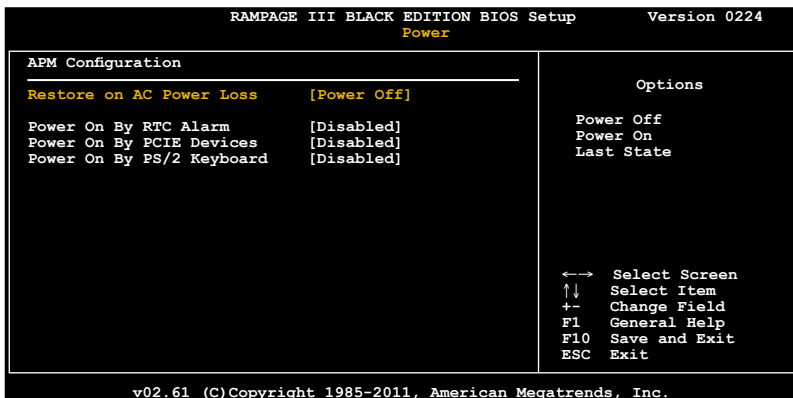

#### Restore On AC Power Loss [Power Off]

[Power Off] The system goes into off state after an AC power loss.

[Power On] The system goes into on state after an AC power loss.

[Last State] The system goes into either off or on state, whatever the system state was before the AC power loss.

### **Power On By RTC Alarm [Disabled]**

Allows you to enable or disable RTC to generate a wake event. When this item is set to [Enabled], the items **RTC Alarm Date (Days)** and **System Time** will become user-configurable with set values.

Configuration options: [Disabled] [Enabled]

[Disabled] Disables RTC to generate a wake event.

[Enabled] When set to [Enabled], the items **RTC Alarm Date (Days)** and **System Time** will become user-configurable with set values.

### **Power On By PCIE Devices [Disabled]**

Allows you to enable or disable the PCIE devices to generate a wake event.

[Disabled] Disables the PCIE devices to generate a wake event.

[Enabled] Enables the PCIE devices to generate a wake event.

### **Power On By PS/2 Keyboard [Disabled]**

Allows you to disable or enable the Power On by PS/2 keyboard function.

Configuration options: [Disabled] [Space Bar] [Ctrl-Esc] [Power Key]

## 3.6.7 Hardware Monitor

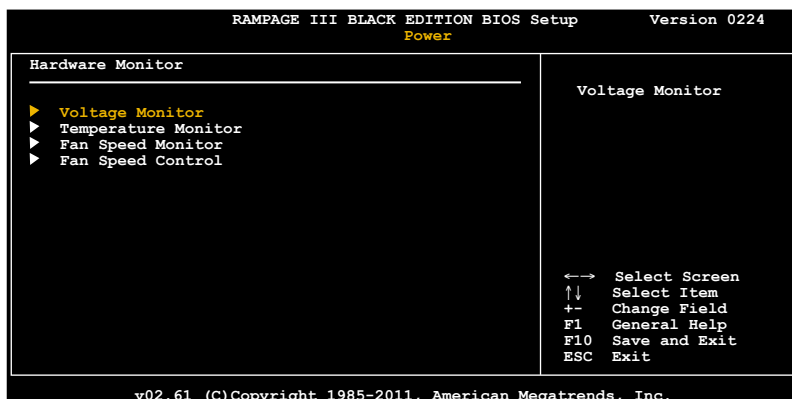

### Voltage Monitor

CPU Voltage; CPU PLL Voltage; QPI/DRAM Core Voltage; IOH Voltage;  
IOH PCIE Voltage; ICH Voltage; DRAM Bus Voltage;  
3.3V Voltage; 5V Voltage; 12V Voltage

The onboard hardware monitor automatically detects the voltage output through the onboard voltage regulators.

### Temperature Monitor

CPU Temperature; MB Temperature;  
OPT FAN1/2/3 Temperature [xxx°C/xxx°F]

The onboard hardware monitor automatically detects and displays the CPU, motherboard, power, and the assigned devices temperatures. Select [Ignored] if you do not wish to display the detected temperatures.

IOH/ICH overheat protection [100°C]

The system automatically shuts down when the IOH/ICH is heated over the set temperature to protect it from damage.

Configuration options: [Disabled] [70°C] [80°C] [90°C] [100°C]

OPT TEMP1/2/3 overheat protection [90°C]

Allows you to set the temperature over which the system automatically shuts down when any of the thermal sensor cables connected to the motherboard detects device overheat to protect the device from damage.

Configuration options: [Disabled] [70°C] [80°C] [90°C] [100°C]

### Fan Speed Monitor

CPU Fan; CPU OPT Fan; Chassis Fan1/2/3 Speed  
OPT Fan1/2/3 Speed [xxxxRPM] or [Ignored] / [N/A]

The onboard hardware monitor automatically detects and displays the CPU fan, chassis fan, and optional fan speed in rotations per minute (RPM). If any of the fans is not connected to the motherboard, the field shows [N/A]. These items are not user-configurable.

## Fan Speed Control

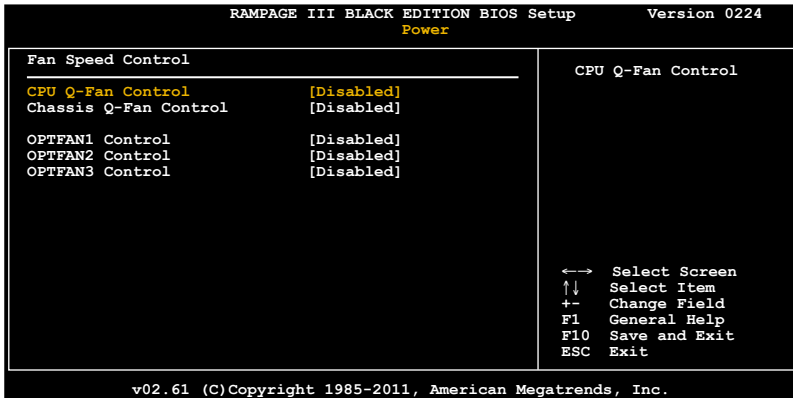

### CPU Q-Fan Control [Disabled]

Allows you to enable or disable the CPU fan controller.

[Disabled] Disables the CPU Q-fan controller.

[Enabled] Enables the CPU Q-fan controller.



The **CPU Fan Profile** item appears when you enable the CPU Fan Control feature.

### **CPU Fan Profile [Standard]**

This item appears only when you enable the **CPU Q-Fan Control** feature and allows you to set the appropriate performance level of the CPU fan.

[Standard] Sets to [Standard] to make the CPU fan automatically adjust depending on the CPU temperature.

[Silent] Sets to [Silent] to minimize the fan speed for quiet CPU fan operation.

[Turbo] Set to [Turbo] to achieve maximum CPU fan speed.

[Manual] Set to [Manual] to customize the CPU fan speed.

### Chassis Q-Fan Control [Disabled]

Allows you to enable or disable the Chassis fan controller.

[Disabled] Disables the Chassis Q-fan controller.

[Enabled] Enables the Chassis Q-fan controller.



---

The **Chassis Fan Profile** item appears when you enable the **Chassis Q-Fan Function** feature.

---

#### **Chassis Fan Profile [Standard]**

This item appears only when you enable the **Chassis Q-Fan Control** feature and allows you to set the appropriate performance level of the chassis fan.

- [Standard] Sets to [Standard] to make the chassis fan automatically adjust depending on the chassis temperature.
- [Silent] Sets to [Silent] to minimize the fan speed for quiet chassis fan operation.
- [Turbo] Set to [Turbo] to achieve maximum chassis fan speed.
- [Manual] Set to [Manual] to customize the chassis fan speed.

#### ***OPTFan1/2/3 Control [Disabled]***

Allows you to select the optional fan control mode. When this item is set to [Duty Mode], you can configure the **OPTFan1/2/3 Duty** item. If you set this item to [User Mode], you are allowed to configure the **OPTFan1/2/3 Low Speed Temp** and **OPTFan1/2/3 Full Speed Temp** item.

Configuration options: [Disabled] [Duty Mode] [User Mode]



---

You need to connect the thermal sensor cables to the OPT\_TEMP1/2/3 connectors to enable this function.

---

#### **OPTFan1/2/3 Duty [60%]**

Allows you to set the fan duty cycle. This item appears when the **OPTFan1/2/3 Control** item is set to [Duty Mode].

Configuration options: [60%] [70%] [80%] [90%]

#### **OPTFan1/2/3 Low Speed Temp [25°C]**

Allows you to set the temperature at which the power fan rotates at low speed. This item appears when the **OPTFan1/2/3 Control** item is set to [User Mode].

Configuration options: [25°C] [30°C] [35°C] [40°C]

#### **OPTFan1/2/3 Full Speed Temp [60°C]**

Allows you to set the temperature at which the power fan rotates at full speed. This item appears when the **OPTFan1/2/3 Control** item is set to [User Mode].

Configuration options: [60°C] [70°C] [80°C] [90°C]

# 3.7 Boot menu

The Boot menu items allow you to change the system boot options. Select an item then press <Enter> to display the sub-menu.

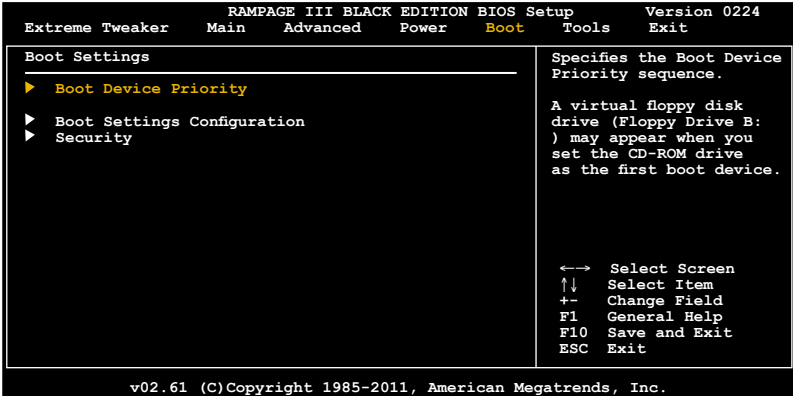

## 3.7.1 Boot Device Priority

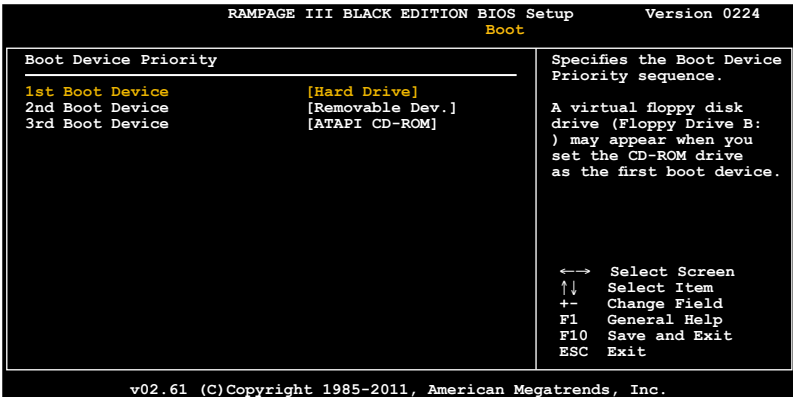

### 1st-xxth Boot Device [xxx Drive]

These items specify the boot device priority sequence from the available devices. The number of device items that appears on the screen depends on the number of devices installed in the system. Configuration options: [xxx Drive] [Disabled]



## 3.7.2 Boot Settings Configuration

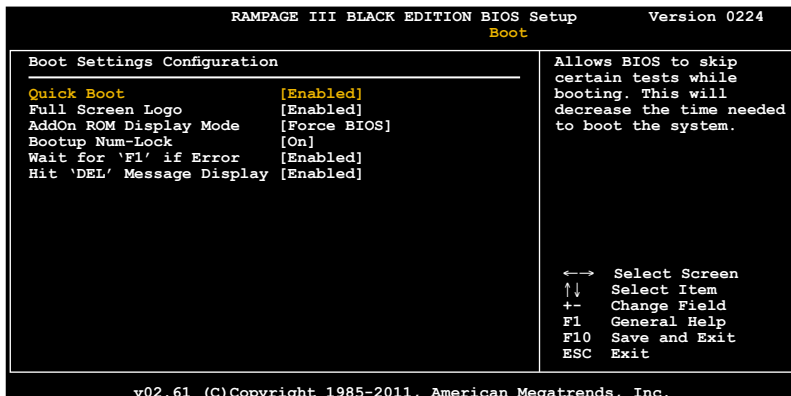

### Quick Boot [Enabled]

Allows you to enable or disable the **Quick Boot** function.

[Disabled] When set to [Disabled], BIOS performs all the POST items.

[Enabled] When set to [Enabled], BIOS skips some power on self tests (POST) while booting to decrease the time needed to boot the system.

### Full Screen Logo [Enabled]

This allows you to enable or disable the full screen logo display feature.

[Enabled] Enables the full screen logo display feature.

[Disabled] Disables the full screen logo display feature.



Set this item to [Enabled] to use the ASUS MyLogo3™ feature.

### AddOn ROM Display Mode [Force BIOS]

Sets the display mode for option ROM.

[Force BIOS]

[Keep Current] .

### Bootup Num-Lock [On]

Allows you to select the power-on state for the NumLock.

[On] Sets the power-on state of the NumLock to [On].

[Off] Sets the power-on state of the NumLock to [Off].

### Wait for 'F1' If Error [Enabled]

When set to [Enabled], the system waits for the <F1> key to be pressed when error occurs.

## Hit 'DEL' Message Display [Enabled]

When set to [Enabled], the system displays the message "Press DEL to run Setup" during POST.

### 3.7.3 Security

The Security menu items allow you to change the system security settings. Select an item then press <Enter> to display the configuration options.

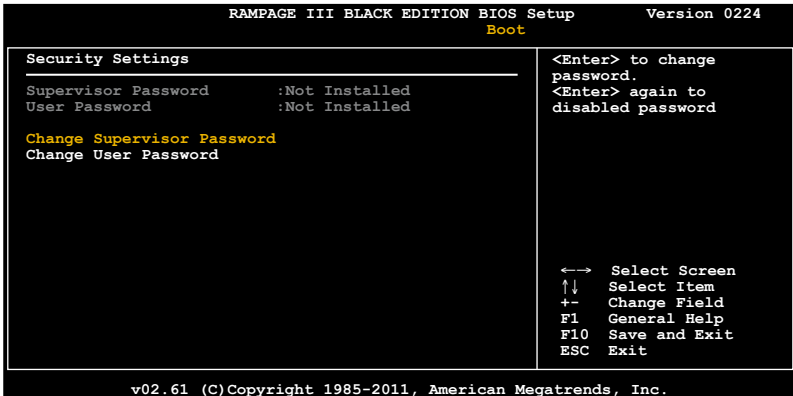

#### Change Supervisor Password

Select this item to set or change the supervisor password. The Supervisor Password item on top of the screen shows the default **Not Installed**. After you set a password, this item shows Installed.

To set a Supervisor Password:

1. Select the **Change Supervisor Password** item and press <Enter>.
2. From the password box, type a password composed of at least six letters and/or numbers, then press <Enter>.
3. Confirm the password when prompted.

The message **Password Installed** appears after you successfully set your password.

To change the supervisor password, follow the same steps as in setting a user password.

To clear the supervisor password, select the **Change Supervisor Password** then press <Enter>. The message **Password Uninstalled** appears.



If you forget your BIOS password, you can clear it by erasing the CMOS Real Time Clock (RTC) RAM. See section 2.2.8 **Jumper** for information on how to erase the RTC RAM.

After you have set a supervisor password, the other items appear to allow you to change other security settings.

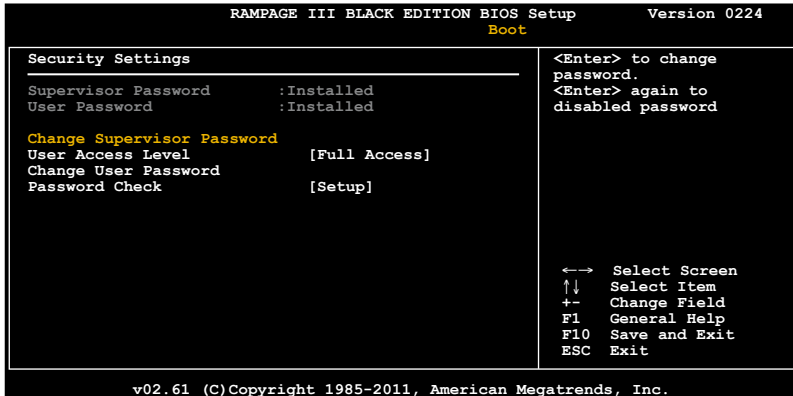

### User Access Level [Full Access]

This item allows you to select the access restriction to the Setup items.

Configuration options: [No Access] [View Only] [Limited] [Full Access]

[No Access] prevents user access to the Setup utility.

[View Only] allows access but does not allow change to any field.

[Limited] allows changes only to selected fields, such as Date and Time.

[Full Access] allows viewing and changing all the fields in the Setup utility.

### Change User Password

Select this item to set or change the user password. The User Password item on top of the screen shows the default Not Installed. After you set a password, this item shows Installed.

To set a User Password:

1. Select the Change User Password item and press <Enter>.
2. On the password box that appears, type a password composed of at least six letters and/or numbers, then press <Enter>.
3. Confirm the password when prompted.

The message "Password Installed" appears after you set your password successfully.

To change the user password, follow the same steps as in setting a user password.

### Password Check [Setup]

When set to [Setup], BIOS checks for user password when accessing the Setup utility. When set to [Always], BIOS checks for user password both when accessing Setup and booting the system. Configuration options: [Setup] [Always]

## 3.8 Tools menu

The Tools menu items allow you to configure options for special functions. Select an item then press <Enter> to display the sub-menu.

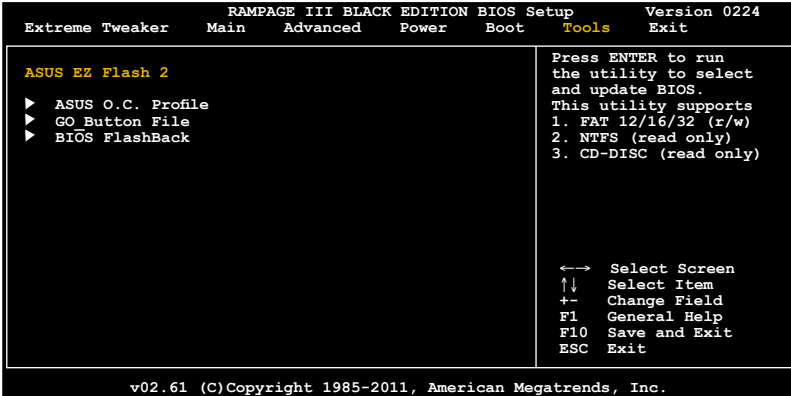

### 3.8.1 ASUS EZ Flash 2

Allows you to run ASUS EZ Flash 2. When you press <Enter>, a confirmation message appears. Use the left/right arrow key to select between [Yes] or [No], then press <Enter> to confirm your choice.



For more details, refer to [section 3.1.2 ASUS EZ Flash 2 utility](#).

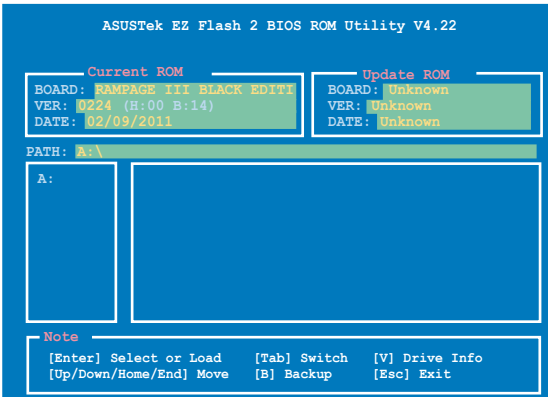

## 3.8.2 ASUS O.C. Profile

This item allows you to store or load multiple BIOS settings.

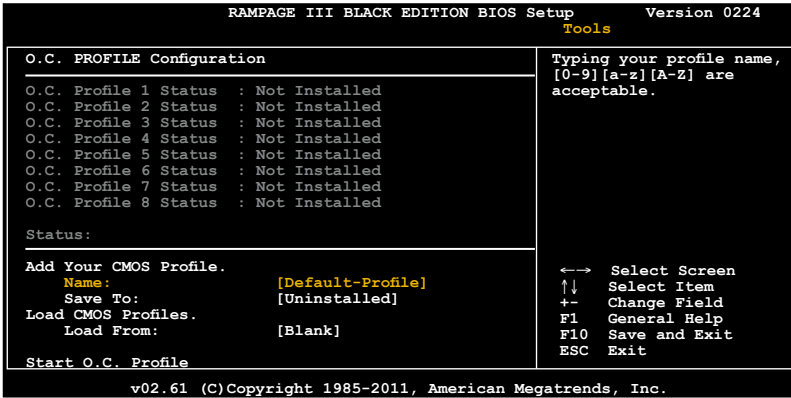

### Add Your CMOS Profile

Allows you to save the current BIOS file to the BIOS Flash. In the Name sub-item, type your profile name and press <Enter>, and then choose a profile number to save your CMOS settings in the Save to sub-item.

### Load CMOS Profiles

Allows you to load the previous BIOS settings saved in the BIOS Flash. Press <Enter>, and choose a profile to load.

### Start O.C. Profile

Allows you to run the utility to save and load CMOS. Press <Enter> to run the utility.

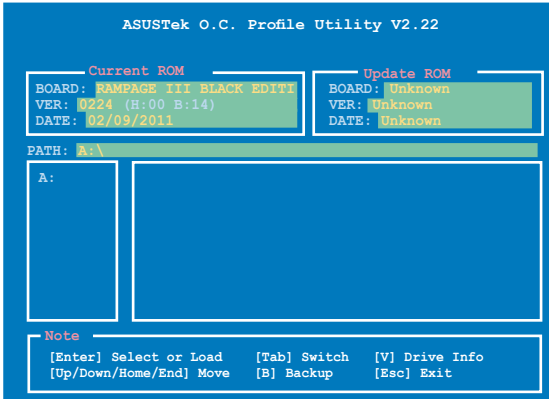

- This function supports devices such as a USB flash disk (FAT 32/16 format) or a floppy disk with single partition only.
- DO NOT shut down or reset the system while updating the BIOS to prevent the system boot failure!
- We recommend that you update the BIOS file only coming from the same memory/CPU configuration and BIOS version.
- Only the CMOS file can be loaded.

### 3.8.3 GO Button File

This menu allows you to set the GO Button files, and load the desired GO\_Button file.

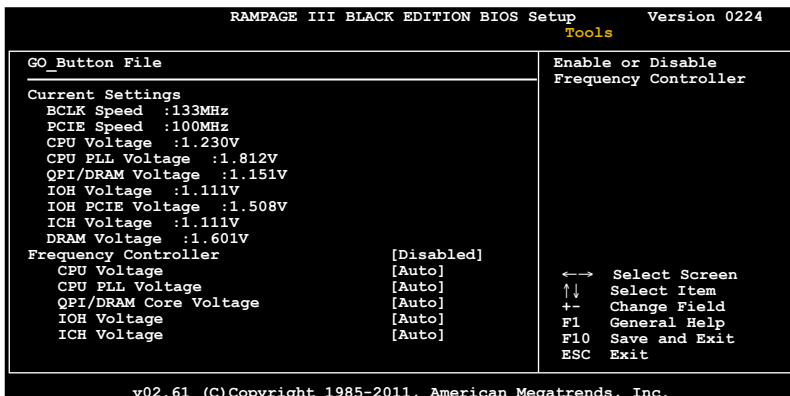

Scroll down to display the following items:

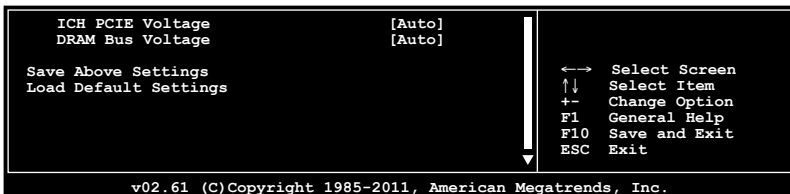

#### Frequency Controller; CPU Voltage; CPU PLL Voltage; QPI/DRAM Core Voltage; IOH Voltage; IOH PCIE Voltage; ICH Voltage; ICH PCIE Voltage; DRAM Bus Voltage

Allows you to use the <+> and <-> keys to adjust the values for each item. Refer to 3.3 Extreme Tweaker Menu for details.

#### Save Above Settings

Allows you to save the adjusted values for specific items as a GO\_Button file.

#### Load Above Settings

Allows you to load the desired GO\_Button file.

## 3.8.4 BIOS FlashBack

```
RAMPAGE III BLACK EDITION BIOS Setup          Version 0224
                                     Tools
Now BIOS status           : BIOS1
Switch BIOS Boot from
  BIOS2
BIOS2
←→ Select Screen
↑↓ Select Item
+- Change Field
F1 General Help
F10 Save and Exit
ESC Exit
v02.61 (C)Copyright 1985-2011, American Megatrends, Inc.
```

### BIOS2

Press <Enter> to change the BIOS ROM for booting.



## 3.9 Exit menu

The Exit menu items allow you to load the optimal or failsafe default values for the BIOS items, and save or discard your changes to the BIOS items.

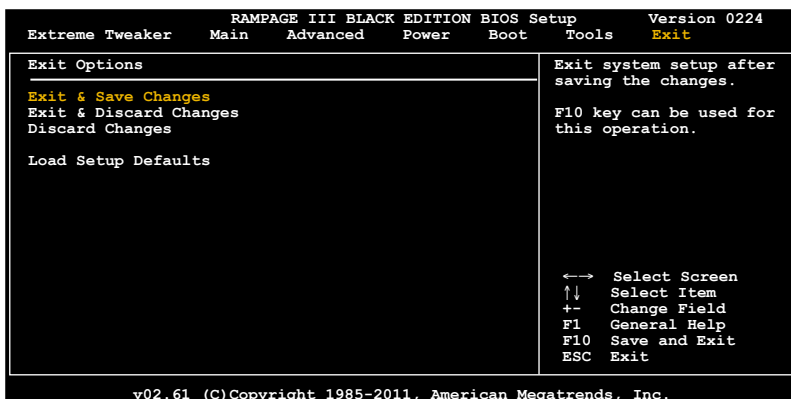

Pressing <Esc> does not immediately exit this menu. Select one of the options from this menu or <F10> from the legend bar to exit.

### Exit & Save Changes

Once you are finished making your selections, choose this option from the Exit menu to ensure the values you selected are saved to the CMOS RAM. An onboard backup battery sustains the CMOS RAM so it stays on even when the PC is turned off. When you select this option, a confirmation window appears. Select YES to save changes and exit.



If you attempt to exit the Setup program without saving your changes, the program prompts you with a message asking if you want to save your changes before exiting. Press <Enter> to save the changes while exiting.

### Exit & Discard Changes

Select this option only if you do not want to save the changes that you made to the Setup program. If you made changes to fields other than System Date, System Time, and Password, the BIOS asks for a confirmation before exiting.

### Discard Changes

This option allows you to discard the selections you made and restore the previously saved values. After selecting this option, a confirmation appears. Select YES to discard any changes and load the previously saved values.

### Load Setup Defaults

This option allows you to load the default values for each of the parameters on the Setup menus. When you select this option or if you press <F5>, a confirmation window appears. Select YES to load default values. Select Exit & Save Changes or make other changes before saving the values to the non-volatile RAM.



This chapter describes the contents of the support DVD that comes with the motherboard package and the software.

# 4 Software support

4.1	Installing an operating system .....	4-1
4.2	Support DVD information .....	4-1
4.3	Software information .....	4-3
4.4	RAID configurations .....	4-28
4.5	Creating a RAID driver disk.....	4-34

## 4.1 Installing an operating system

This motherboard supports Windows® XP/ 64-bit XP/ Vista / 64-bit Vista / 7 / 64-bit 7 operating systems (OS). Always install the latest OS version and corresponding updates to maximize the features of your hardware.



- Motherboard settings and hardware options vary. Use the setup procedures presented in this chapter for reference only. Refer to your OS documentation for detailed information.
- Ensure that you install the Windows® XP Service Pack 2 or later versions before installing the drivers for better compatibility and system stability.

## 4.2 Support DVD information

The support DVD that comes with the motherboard package contains the drivers, software applications, and utilities that you can install to avail all motherboard features.



The contents of the support DVD are subject to change at any time without notice. Visit the ASUS website at [www.asus.com](http://www.asus.com) for updates.

### 4.2.1 Running the support DVD

Place the support DVD into the optical drive. The DVD automatically displays the Drivers menu if Autorun is enabled in your computer. Click each menu tab and select the items you want to install.

The Drivers menu shows the available device drivers if the system detects installed devices. Install the necessary drivers to use the devices.

The Make Disk menu contains items to create the RAID/AHCI driver disk.

The Manual menu contains the list of supplementary user manuals. Click an item to open the folder of the user manual.

The Utilities menu shows the applications and other software that the motherboard supports.

Click an item to install

Click the Contact tab to display the ASUS contact information.

Click an icon to display DVD/ motherboard information

The screenshot shows the ASUS support DVD interface. At the top, there are tabs for 'Driver', 'Utility', 'Make Disk', 'Manual', 'Video', and 'Contact'. The 'Driver' tab is selected, displaying a list of drivers: 'ASUS InstAll', 'Intel Chipset Driver', 'Realtek Audio Driver', 'JMicron JMB36X Controller Driver', 'Intel LAN Driver', 'USB 3.0 Driver', 'ASUS Bluetooth3.0 Driver', 'ASUS ROG THUNDERBOLT Audio Driver', 'ASUS ROG THUNDERBOLT LAN Driver', and 'Browser Configuration Utility'. On the right side, there is a 'Please select items to install' section with icons for 'MB' (Motherboard), a DVD, and a manual. Arrows from the surrounding text point to these elements.



If Autorun is NOT enabled in your computer, browse the contents of the support DVD to locate the file ASSETUP.EXE from the BIN folder. Double-click the ASSETUP.EXE to run the DVD.

## 4.2.2 Obtaining the software manuals

The software manuals are included in the support DVD. Follow the instructions below to get the necessary software manuals.



The software manual files are in Portable Document Format (PDF). Install the Adobe® Acrobat® Reader from the Utilities menu before opening the files.

1. Click the **Manual** tab. Click **ASUS Motherboard Utility Guide** from the manual list on the left.



2. The **Manual** folder of the support DVD appears. Double-click the folder of your selected software.

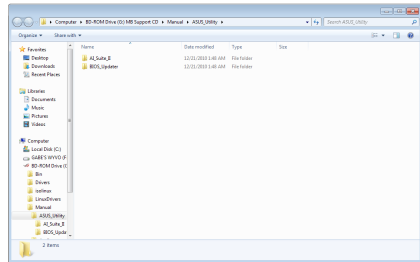

3. Some software manuals are provided in different languages. Double-click the language to show the software manual.

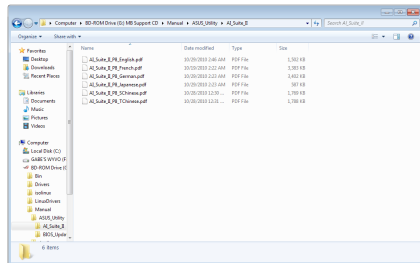

The screenshots in this section are for reference only. The actual software manuals containing in the support DVD vary by models.

## 4.3 Software information

Most of the applications in the support DVD have wizards that will conveniently guide you through the installation. View the online help or readme file that came with the software application for more information.

### 4.3.1 AI Suite II

AI Suite II is an all-in-one interface that integrates several ASUS utilities and allows users to launch and operate these utilities simultaneously.

#### Installing AI Suite II

To install AI Suite II on your computer

1. Place the support DVD to the optical drive. The Drivers installation tab appears if your computer has enabled the Autorun feature.
2. Click the Utilities tab, then click **AI Suite II**.
3. Follow the onscreen instructions to complete installation.

#### Using AI Suite II

AI Suite II automatically starts when you enter the Windows® operating system (OS). The AI Suite II icon appears in the Windows® notification area. Click the icon to open the AI Suite II main menu bar.

Click each button to select and launch a utility, to monitor the system, to update the motherboard BIOS, to display the system information, and to customize the settings of AI Suite II.

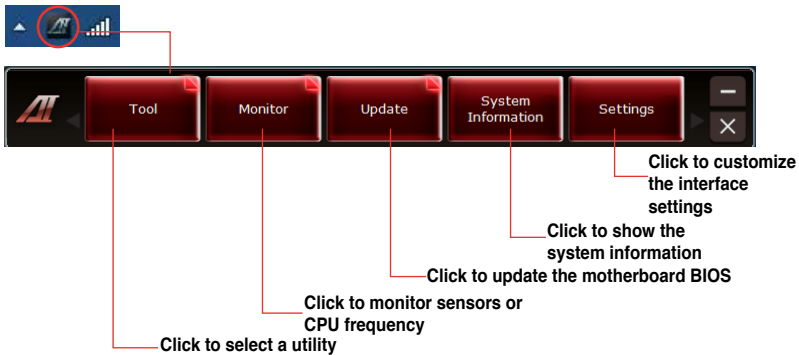

- The applications in the Tool menu vary with models.
- The screenshots of AI Suite II in this user manual are for reference only. The actual screenshots vary with models.
- Refer to the software manual in the support DVD or visit the ASUS website at [www.asus.com](http://www.asus.com) for detailed software configuration.

### 4.3.2 DIGI+ VRM

ASUS DIGI+ VRM allows you to adjust VRM voltage and frequency modulation to enhance reliability and stability. It also provides the highest power efficiency, generating less heat to longer component lifespan and minimize power loss.

After installing AI Suite II from the motherboard support DVD, launch DIGI+ VRM by clicking **Tool > DIGI+ VRM** on the AI Suite II main menu bar.

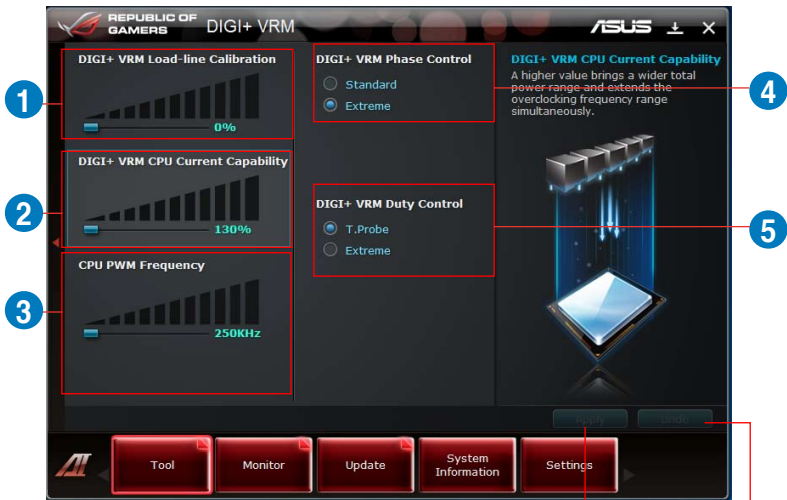

Undo all changes without applying

Apply all changes immediately

#### 1. DIGI+ VRM Load-line Calibration

Higher load-line calibration could get higher voltage and good overclocking performance but increase the CPU and VRM thermal.

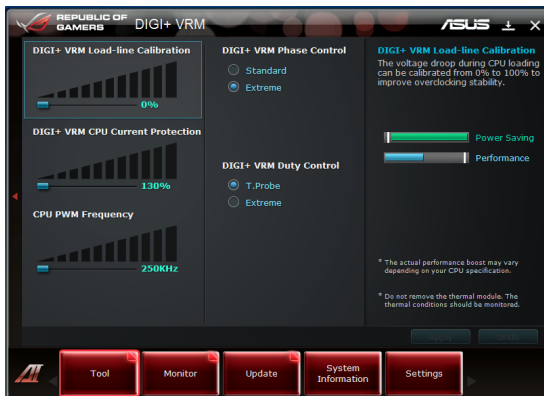



## 2. DIGI+ VRM CPU Current Protection

DIGI+ VRM CPU Current Protection provides wider total power range for overclocking. A higher value setting gets higher VRM power consumption delivery.



## 3. CPU PWM Frequency

Switching frequency will affect the PWM transient response and component thermal. Higher frequency gets quicker transient response.

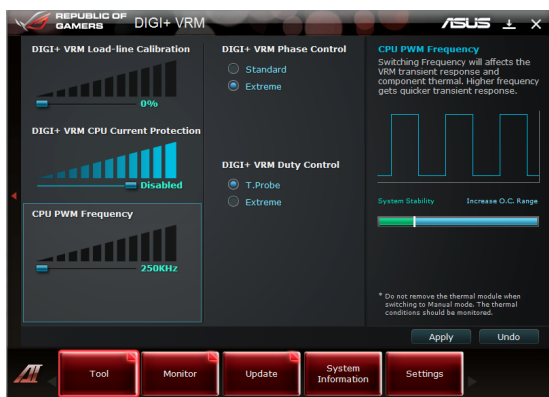

## 4. DIGI+ VRM Phase Control

Phase number is the number of working VRM phase. Choose **Extreme** for heavy system loading to get more transient and better thermal performance or **Standard** to change based on CPU command.

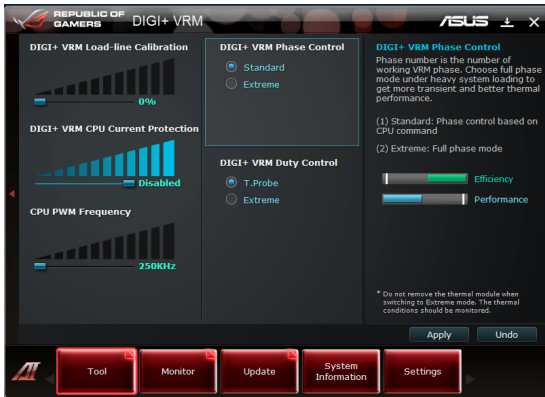

## 5. DIGI+ VRM Duty Control

DIGI+ VRM Duty Control adjusts the current of every VRM phase and the thermal of every phase component.

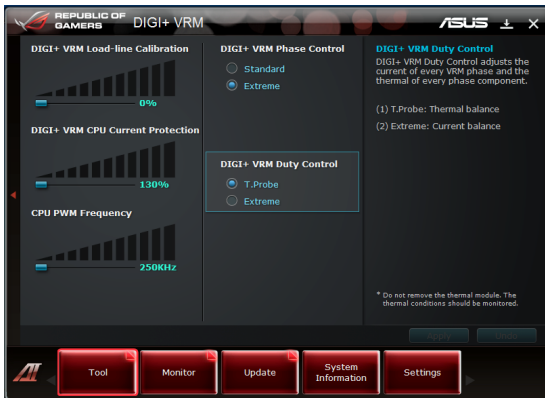

- The actual performance boost may vary depending on your CPU specification.
- Do not remove the thermal module. The thermal conditions should be monitored.



Refer to the software manual in the support DVD or visit the ASUS website at [www.asus.com](http://www.asus.com) for detailed software configuration.

### 4.3.3 TurboV EVO

ASUS TurboV EVO introduces **TurboV** that allows you to manually adjust the CPU frequency and related voltages. After installing AI Suite II from the motherboard support DVD, launch TurboV EVO by clicking **Tool > TurboV EVO** on the AI Suite II main menu bar.



Refer to the software manual in the support DVD or visit the ASUS website at [www.asus.com](http://www.asus.com) for detailed software configuration.

#### TurboV

**TurboV** allows you to overclock the BCLK frequency, CPU voltage, QPI/DRAM core voltage, and DRAM Bus voltage in Windows® environment and takes effect in real-time without exiting and rebooting the OS.



Refer to the CPU documentation before adjusting CPU voltage settings. Setting a high voltage may damage the CPU permanently, and setting a low voltage may make the system unstable.



For system stability, all changes made in **TurboV** will not be saved to BIOS settings and will not be kept on the next system boot. Use the **Save Profile** function to save your customized overclocking settings and manually load the profile after Windows starts.

**CPU Level Up**

**TurboV Load profile Target values**

**Current values**

**Click to show / hide more settings**

**Click to restore all start-up settings**

**Save the current settings as a new profile**

**Voltage Adjustment bars**

**Undoes all changes without applying all changes immediately**



For advanced overclock ability, adjust first the BIOS items, and then proceed more detailed adjustments in **More Settings**.

## Using Advanced Mode

Click **More Settings**, and then click the **Advanced Mode** tab to adjust the advanced voltage settings.

Advanced mode Target values

Current values

Click to restore all start-up settings

Voltage Adjustment bars

Undoes all changes without applying

Applies all changes immediately

## CPU Ratio

Allows you to manually adjust the CPU ratio.

1. Click **More Settings**, and then click the **CPU Ratio** tab.
2. Drag the adjustment bar upwards or downwards to the desired value.

Adjustment bar



- Set the **CPU Ratio Setting** item in BIOS to [Auto] before using the CPU Ratio function in TurboV. Refer to Chapter 3 of your motherboard user manual for details.
- The CPU Ratio bars show the status of the CPU cores, which vary with your CPU model.

## 4.3.4 EPU

EPU is an energy-efficient tool that satisfies different computing needs. This utility provides several modes that you can select to save system power. Selecting Auto mode will have the system shift modes automatically according to current system status. You can also customize each mode by configuring settings like CPU frequency, GPU frequency, vCore Voltage, and Fan Control.

### Launching EPU

After installing AI Suite II from the motherboard support DVD, launch EPU by clicking **Tool > EPU** on the AI Suite II main menu bar.

The screenshot shows the ASUS EPU Control Panel. On the left, there are three mode selection buttons: 'Auto', 'High performance', and 'Max. power saving'. The main area features a central pentagonal diagram with five nodes: 'Tranquility', 'Performance', 'Convenience', 'Reliability', and 'Energy Saved'. To the right, a 'Sensor' panel displays 'EPU Status' and 'Mode' (set to 'High performance'). Below this, icons for CPU, HDD, FAN, Chipset, Memory, and VGA are shown, with the CPU icon highlighted. Further down, it shows 'Reduced CO2 Emission' (0.000 mg) and 'Time Started' (Since: 2011/02/16 10:59), with options for 'From EPU Installation' and 'From the Last Reset'. At the bottom, it displays 'Current CPU Power' (16.43 Watts). A bottom navigation bar includes 'Tool', 'Monitor', 'Update', 'System Information', and 'Settings'. A 'Warning' dialog box is also visible, stating: 'No VGA detected. Please install a compatible VGA card or reset and enable the ASUS PowerDirector. For the list of compatible VGA cards, visit the http://www.asus.com/hiback\_enlight/ OK'.

Displays the following message if no VGA power saving engine is detected.

Displays current mode

The items lighting up means power saving engine is activated

Displays the amount of CO2 reduced

\*Shifts between the display of Total and Current CO2 reduced

Displays the current CPU power

Advanced settings for each mode

Multiple system operating modes

Displays the system properties of each mode



- \*. Select **From EPU Installation** to show the CO2 that has been reduced since you installed EPU.
- \*. Select **From the Last Reset** to show the total CO2 that has been reduced since you click the Clear button **Clear**.
- Refer to the software manual in the support DVD or visit the ASUS website at [www.asus.com](http://www.asus.com) for detailed software configuration.

### 4.3.5 FAN Xpert

Fan Xpert intelligently allows you to adjust both the CPU and chassis fan speeds according to different ambient temperatures caused by different climate conditions in different geographic regions and your PC's system loading. The built-in variety of useful profiles offer flexible controls of fan speed to achieve a quiet and cool environment.

#### Launching FAN Xpert

After installing AI Suite II from the motherboard support DVD, launch FAN Xpert by clicking **Tool > Fan Xpert** on the AI Suite II main menu bar.

#### Using FAN Xpert

Click **Fan Name** to select a fan and then click **Setting** to select a preset mode for your selected fan.

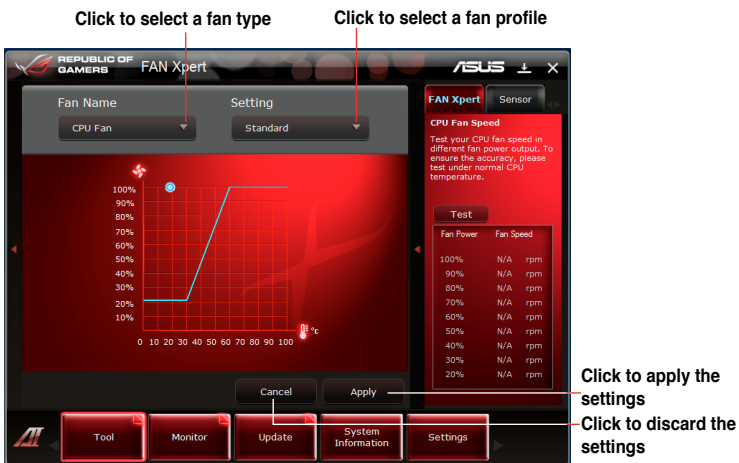

#### Fan setting

- **Disable:** disables the **Fan Xpert** function.
- **Standard:** adjusts fan speed in a moderate pattern.
- **Silent:** minimizes fan speed for quiet fan operation.
- **Turbo:** maximizes the fan speed for the best cooling effect.
- **Intelligent:** automatically adjusts the CPU fan speed according to the ambient temperature.
- **Stable:** fixes the CPU fan speed to avoid noise caused by the unsteady fan rotation. However, the fan will speed up when the temperature exceeds 70°C.
- **User:** Allows you to configure the CPU fan profile under certain limitations.



Refer to the software manual in the support DVD or visit the ASUS website at [www.asus.com](http://www.asus.com) for detailed software configuration.

## 4.3.6 Probe II

Probe II is a utility that monitors the computer's vital components, and detects and alerts you of any problem with these components. Probe II senses fan rotations, CPU temperature, and system voltages, among others. With this utility, you are assured that your computer is always at a healthy operating condition.

### Launching Probe II

After installing AI Suite II from the motherboard support DVD, launch Probe II by clicking **Tool > Probe II** on the AI Suite II main menu bar.

### Configuring Probe II

Click the **Voltage/Temperature/Fan Speed** tabs to activate the sensors or to adjust the sensor threshold values. The **Preference** tab allows you to customize the time interval of sensor alerts, or change the temperature unit.



Saves your configuration

Loads your saved configuration

Loads the default threshold values for each sensor

Applies your changes



Refer to the software manual in the support DVD or visit the ASUS website at [www.asus.com](http://www.asus.com) for detailed software configuration.

### 4.3.7 ROG Connect

ROG Connect allows you to monitor and adjust the local PC through your remote PC.

#### Setting up USB connection between your local and remote PC



- Install **ROG Connect** on the remote PC from the provided Support DVD before using ROG Connect.
- **ROG Connect** must work with **ROG Connect Plus** to avail full function. Ensure that you install **ROG Connect Plus** on your local PC from the provided Support DVD before using **ROG Connect**.

1. Connect the provided ROG Connect cable to the local PC and the remote PC.
2. Press the ROG Connect Button.
3. Double-click the **RC TweakIt** shortcut on the remote PC to activate the function

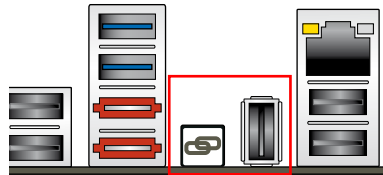

#### Using RC TweakIt

Use the sliders and buttons to monitor or adjust your local PC.





Click **Function** to display more options.

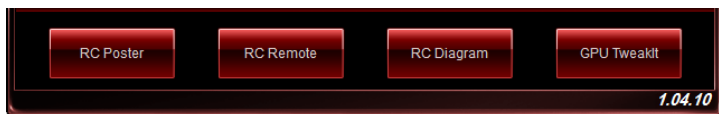

## RC Poster

RC Poster shows the status of the local system during the POST. You can switch the display mode between **String** and **Code**.



## RC Remote

RC Remote allows you to operate your local system through the ROG Connect cable.



## RC Diagram

RC Diagram allows you to monitor and record your local system status.

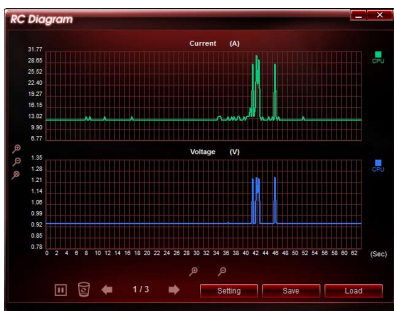

## GPU TweakIt

GPU TweakIt allows you to control and monitor the installed GPU on the local system. Use the sliders to adjust the values and click **Apply** to save your customized settings.

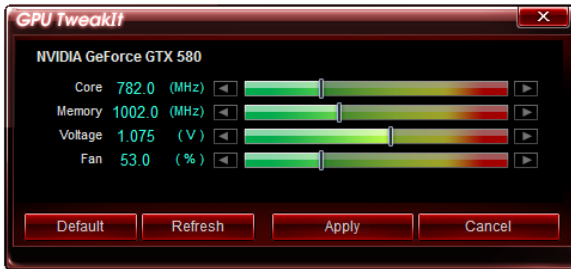

## 4.3.8 ThunderBolt LAN--Bigfoot Killer Network Manager

1. Double-click **Bigfoot Killer Network Manager** on the desktop.
2. Ensure that you have connected to the internet and click **Start** to perform the bandwidth test.

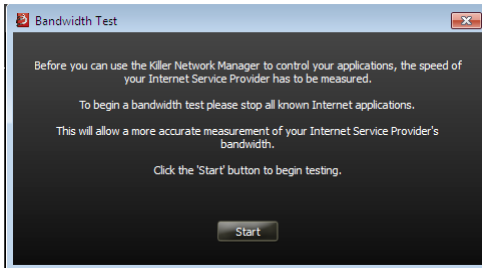
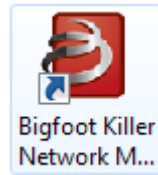

### Network

Click the **Network** tab on the left to configure your network settings.

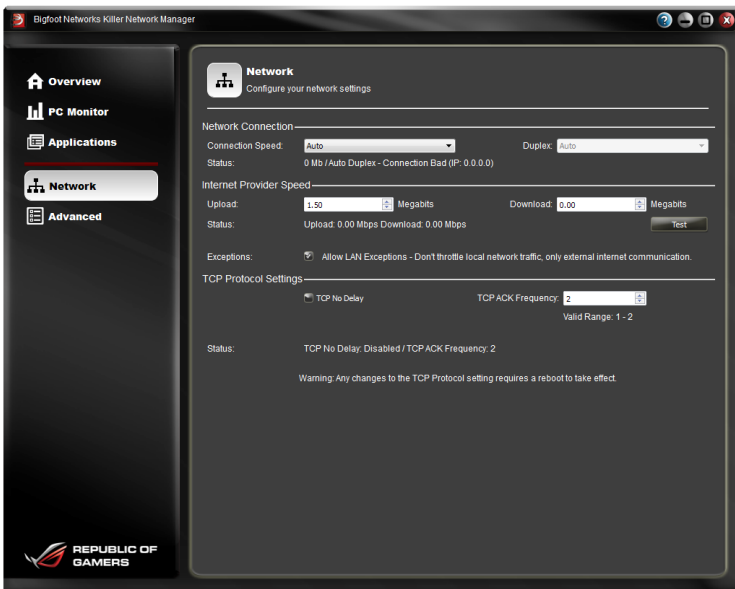

## Advanced

Click the **Advanced** tab on the left to configure **Killer Network Manager** settings. You can select the display information, set up the application control, and other configurations.

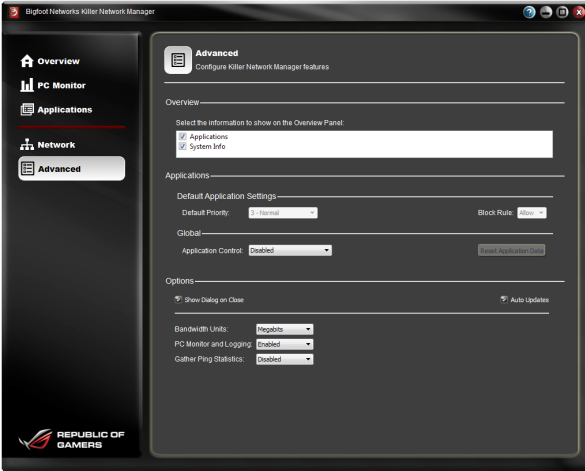

## Overviews

Click the **Overview** tab on the left to see the system information and the current status of the network connection.

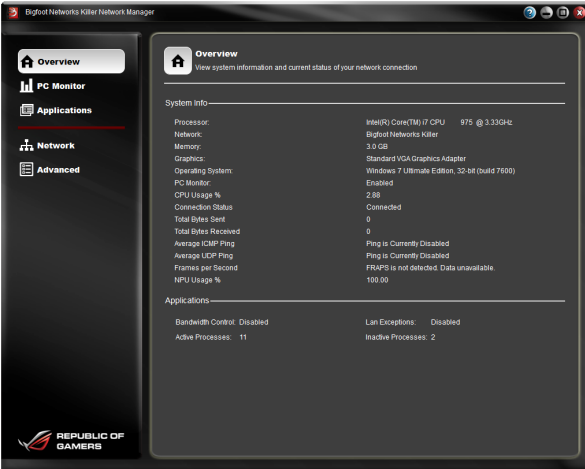

## PC Monitor

Click the **PC Monitor** tab on the left to monitor and record the performance of your system. Click **View Type** to select a desired device for monitoring.

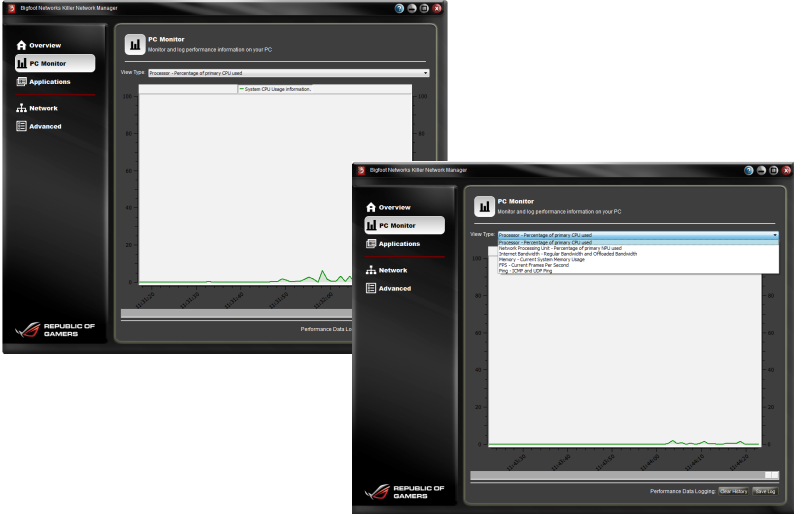

## Applications

Click the **Applications** tab on the left to see the network usage of each applications.

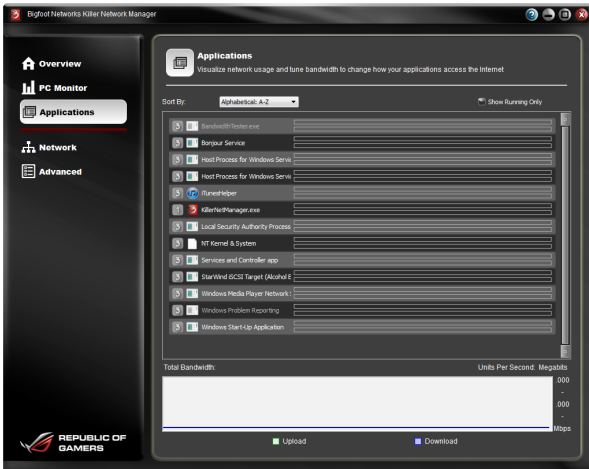

To see the network usage of the applications, you have to enable the application control first. Click the **Advanced** tab and enable the **Application Control**.

### 4.3.9 ThunderBolt Audio

Double-click **ROG ThunderBolt Audio** on the desktop.



#### Main Control Panel

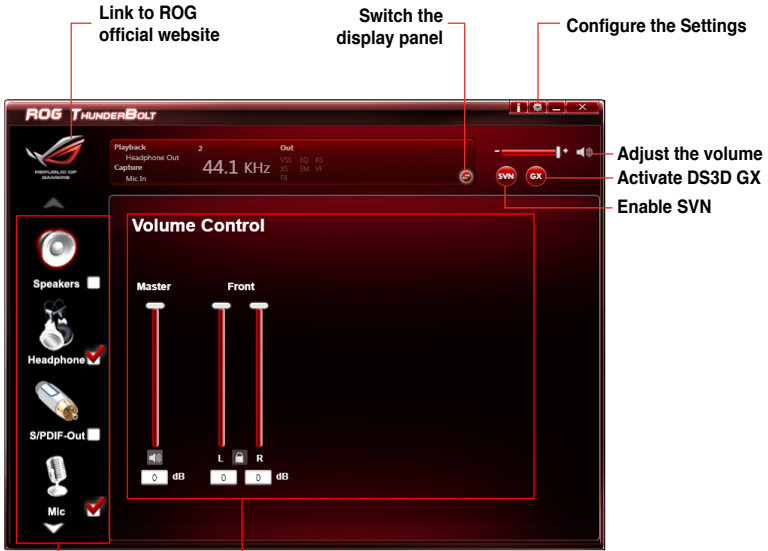

- **SVN (Smart Volume Normalization):** Enable this function to avoid large volume fluctuations.
- **DS3D GX:** Enable DirectSound3D Game Extensions to support EAX and DirectSound3D extensions for EAX and DS3D games on Windows.



- If you connect your speakers or headphone to the audio jack of the **TunderBolt bracket**, select **Speakers** as your default audio output device.
- If you connect your speakers or headphone to the audio jack of the **chassis front panel**, select **Headphone** as your default audio output device.







## Game Profiles

Click the **Switch** to switch the panel from Status Panel to the Game Profiles Panel. Click the plus sign (+) to add your customized profiles or the minus sign (-) to delete unwanted profiles.

Switch to the corresponding game profile according to the game you play.



	FPS Mode (First Person Shooter mode)
	HiFi Mode
	Racing Mode
	RTS Mode (Real-Time Strategy mode)
	Manual (You customized mode)

## Audio output

Click the corresponding box to select from **Speakers**, **Headphones**, and **SPDIF-Out** for the output device. Click each button directly to configure the related settings.

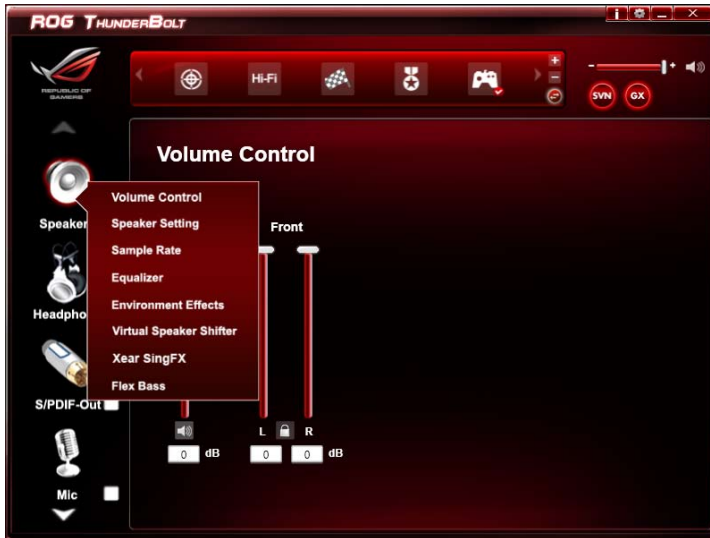

### Headphone Settings

Click **Headphone** and select **Headphone Settings** to do the gain adjustment. Select the gain tuning according to your headphone impedance.



A wrong gain tuning setting may damage your headphone. Select a proper gain according to your headphone specification.



Only audio output from the front panel via the AAFP cable supports the headphone gain tuning function.



### Xear Surround Effect

Click **Headphone** and select **Xear Surround Effect** to enable the **Xear Surround Effect**.



Ensure to select a proper **Room Size** for a better surround effect.

### **Audio input**

Click the corresponding box to select from **Mic** and **Line-In** for the input device. Click each button directly to configure the related settings.

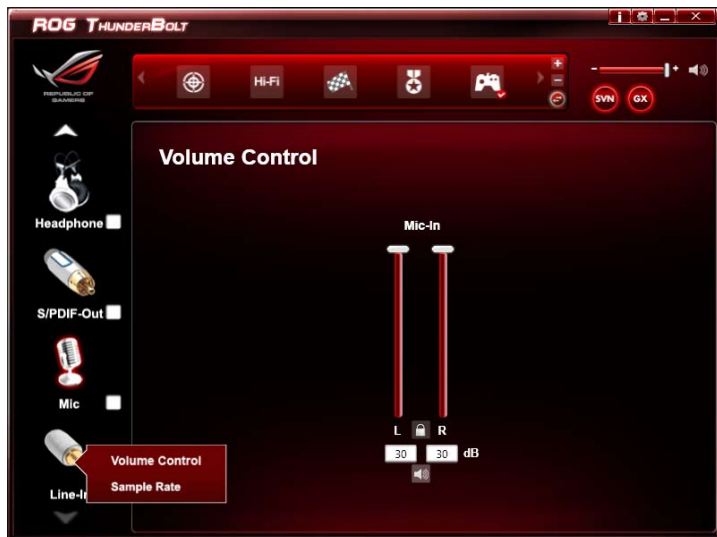

### 4.3.10 ROG Wi-Fi Agent

ROG Wi-Fi Agent allows your system to access the internet wirelessly as a client or makes your system an access point (AP) for internet sharing.



#### Client

To access the internet as a client

1. Ensure you have switched to **Client** mode. Click the switch on the right, if not.
2. Click the wireless network icon with an orange star  in the Windows Notification area.
3. Select the wireless access point you want to connect to from the list and click **Connect** to build the connection.
4. The related information is displayed as shown.

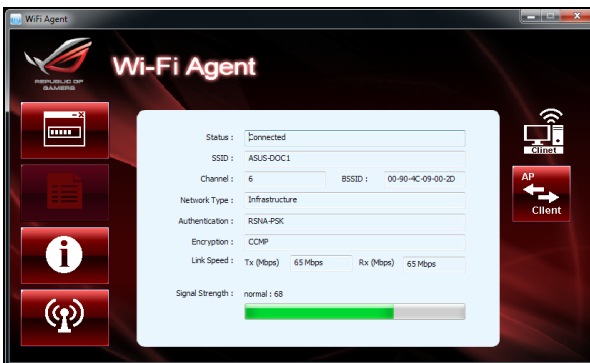

## AP

To make your system an access point

1. Ensure you have switched to **AP** mode. Click the switch on the right, if not.
2. Enter the SSID and security key for this access point.

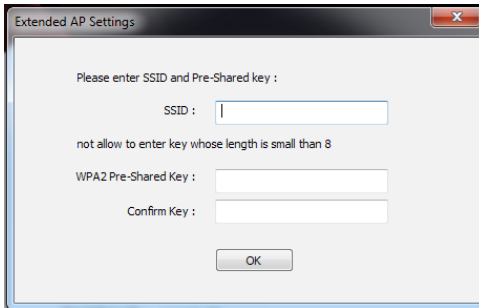

## Config

Allows you to change the AP settings, including, SSID and security key.

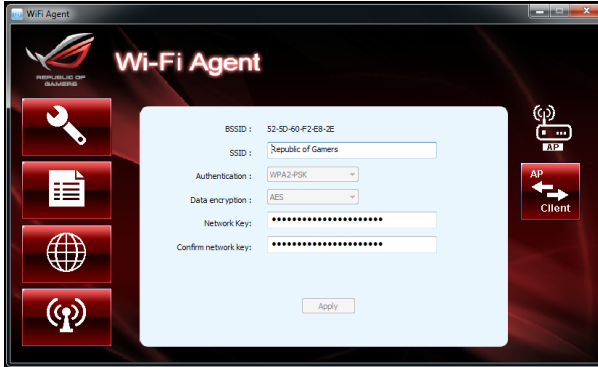

### Association List

Allows you to monitor and manage the connected clients.

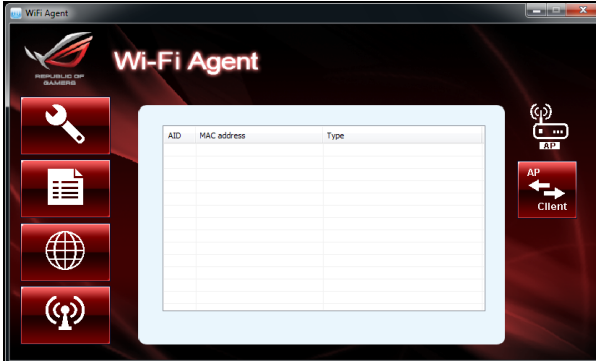

### ICS (Internet connection sharing)

Allows you to choose and switch the LAN port that you want to do internet connection sharing.



### 4.3.11 Audio configurations

The Realtek® audio CODEC provides 8-channel audio capability to deliver the ultimate audio experience on your computer. The software provides Jack-Detection function, S/PDIF Out support, and interrupt capability. The CODEC also includes the Realtek® proprietary UAJ® (Universal Audio Jack) technology for all audio ports, eliminating cable connection errors and giving users plug and play convenience.

Follow the installation wizard to install the Realtek® Audio Driver from the support DVD that came with the motherboard package.

If the Realtek audio software is correctly installed, you will find the **Realtek HD Audio Manager** icon on the taskbar. Double-click on the icon to display the Realtek HD Audio Manager.



#### A. Realtek HD Audio Manager for Windows® Vista™

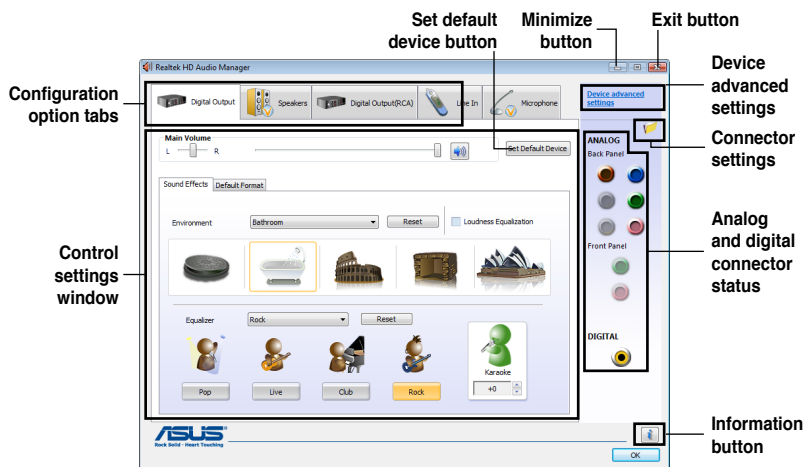

## B. Realtek HD Audio Manager for Windows XP



Refer to the software manual in the support DVD or visit the ASUS website at [www.asus.com](http://www.asus.com) for detailed software configuration.

## 4.4 RAID configurations

The motherboard supports the following SATA RAID solution:

- **Intel® Rapid Storage Technology** with RAID 0, RAID 1, RAID 10 and RAID 5 support.



- You must install Windows® XP Service Pack 2 or later versions before using Serial ATA hard disk drives. The Serial ATA RAID feature is available only if you are using Windows® XP SP2 or later versions.
- Due to Windows® XP / Vista limitation, a RAID array with the total capacity over 2TB cannot be set as a boot disk. A RAID array over 2TB can only be set as a data disk only.
- If you want to install a Windows® operating system to a hard disk drive included in a RAID set, you have to create a RAID driver disk and load the RAID driver during OS installation. Refer to section **4.5 Creating a RAID driver disk** for details.

### 4.4.1 RAID definitions

**RAID 0 (Data striping)** optimizes two identical hard disk drives to read and write data in parallel, interleaved stacks. Two hard disks perform the same work as a single drive but at a sustained data transfer rate, double that of a single disk alone, thus improving data access and storage. Use of two new identical hard disk drives is required for this setup.

**RAID 1 (Data mirroring)** copies and maintains an identical image of data from one drive to a second drive. If one drive fails, the disk array management software directs all applications to the surviving drive as it contains a complete copy of the data in the other drive. This RAID configuration provides data protection and increases fault tolerance to the entire system. Use two new drives or use an existing drive and a new drive for this setup. The new drive must be of the same size or larger than the existing drive.

**RAID 5** stripes both data and parity information across three or more hard disk drives. Among the advantages of RAID 5 configuration include better HDD performance, fault tolerance, and higher storage capacity. The RAID 5 configuration is best suited for transaction processing, relational database applications, enterprise resource planning, and other business systems. Use a minimum of three identical hard disk drives for this setup.

**RAID 10** is data striping and data mirroring combined without parity (redundancy data) having to be calculated and written. With the RAID 10 configuration you get all the benefits of both RAID 0 and RAID 1 configurations. Use four new hard disk drives or use an existing drive and three new drives for this setup.

## 4.4.2 Installing Serial ATA hard disks

The motherboard supports Serial ATA hard disk drives. For optimal performance, install identical drives of the same model and capacity when creating a disk array.

To install the SATA hard disks for a RAID configuration:

1. Install the SATA hard disks into the drive bays.
2. Connect the SATA signal cables.
3. Connect a SATA power cable to the power connector on each drive.

## 4.4.3 Setting the RAID item in BIOS

You must enable the RAID function in the BIOS Setup before creating RAID set(s) using SATA HDDs. To do this:

1. Enter the BIOS Setup during POST.
2. Go to the **Main** menu > **Storage Configuration**, and then press <Enter>.
3. Set the **Configure SATA as** item to [RAID].
4. Save your changes, and then exit the BIOS Setup.



---

Refer to Chapter 3 for details on entering and navigating through the BIOS Setup.

---



---

Due to chipset limitation, when set any of SATA ports to RAID mode, all SATA ports run at RAID mode together.

---



## 4.4.4 Intel® Rapid Storage Technology Option ROM utility

To enter the Intel® Rapid Storage Technology Option ROM utility:

1. Turn on the system.
2. During POST, press <Ctrl> + <I> to display the utility main menu.

```
Intel(R) Rapid Storage Technology - Option ROM - v10.1.0.1008
Copyright(C) 2003-10 Intel Corporation. All Rights Reserved.

[ MAIN MENU ]
1. Create RAID Volume
2. Delete RAID Volume
3. Reset Disks to Non-RAID
4. Recovery Volume Options
5. Exit

[ DISK/VOLUME INFORMATION ]

RAID Volumes:
None defined.

Physical Devices:
Port Device Model Serial # Size Type/Status (Vol ID)
0 ST3160812AS 9LS0HJA4 149.0GB Non-RAID Disk
1 ST3160812AS 9LS0F4HL 149.0GB Non-RAID Disk
2 ST3160812AS 3LS0JYL8 149.0GB Non-RAID Disk
3 ST3160812AS 9LS0BJ5H 149.0GB Non-RAID Disk

[↑↓]-Select [ESC]-Exit [ENTER]-Select Menu
```

The navigation keys at the bottom of the screen allow you to move through the menus and select the menu options.



The RAID BIOS setup screens shown in this section are for reference only and may not exactly match the items on your screen.



The utility supports maximum four hard disk drives for RAID configuration.

## Creating a RAID set

To create a RAID set:

1. From the utility main menu, select **1. Create RAID Volume** and press <Enter>. The following screen appears:

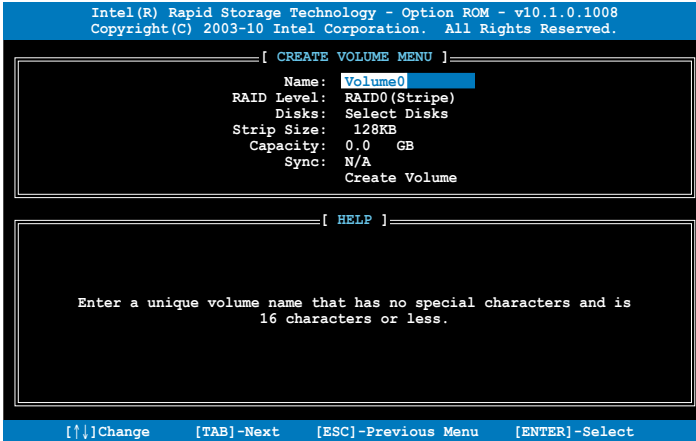

2. Enter a name for the RAID set and press <Enter>.
3. When the **RAID Level** item is selected, press the up/down arrow key to select a RAID level to create, and then press <Enter>.
4. When the **Disks** item is selected, press <Enter> to select the hard disk drives you want to include in the RAID set. The **SELECT DISKS** screen appears:

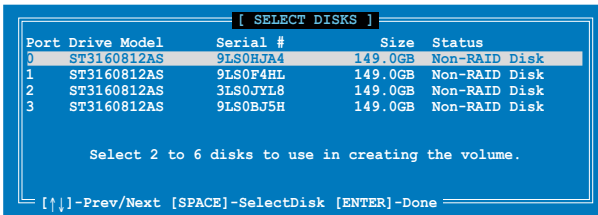

5. Use the up/down arrow key to select a drive, and then press <Space> to select. A small triangle marks the selected drive. Press <Enter> after completing your selection.
6. Use the up/down arrow key to select the stripe size for the RAID array (for RAID 0, 10 and 5 only), and then press <Enter>. The available stripe size values range from 4KB to 128KB. The following are typical values:  
RAID 0: 128KB  
RAID 10: 64KB  
RAID 5: 64KB



---

We recommend a lower stripe size for server systems, and a higher stripe size for multimedia computer systems used mainly for audio and video editing.

---

7. When the **Capacity** item is selected, enter the RAID volume capacity that you want and press <Enter>. The default value indicates the maximum allowed capacity.
8. When the **Create Volume** item is selected, press <Enter>. The following warning message appears:



9. Press <Y> to create the RAID volume and return to the main menu, or <N> to go back to the **CREATE VOLUME** menu.

## Deleting a RAID set



Take caution when deleting a RAID set. You will lose all data on the hard disk drives when you delete a RAID set.

To delete a RAID set:

1. From the utility main menu, select **2. Delete RAID Volume** and press <Enter>. The following screen appears:

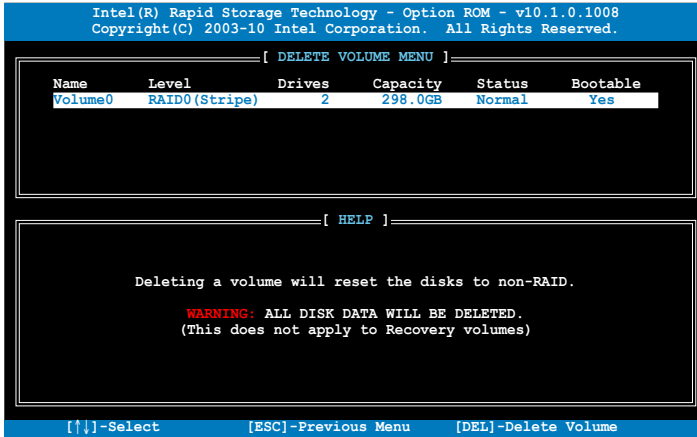

2. Use the up/down arrow key to select the RAID set you want to delete, and then press <Del>. The following warning message appears:

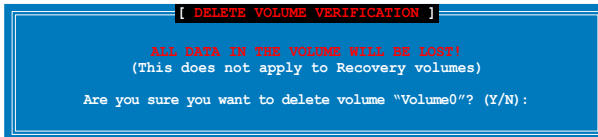

3. Press <Y> to delete the RAID set and return to the utility main menu, or press <N> to return to the **DELETE VOLUME** menu.

## Exiting the Intel® Rapid Storage Technology Option ROM utility

To exit the utility:

1. From the utility main menu, select **5. Exit**, and then press <Enter>. The following warning message appears:

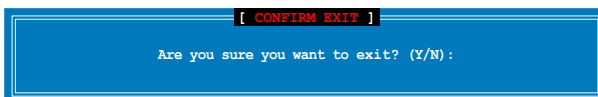

2. Press <Y> to exit or press <N> to return to the utility main menu.

## 4.5 Creating a RAID driver disk

A floppy disk with the RAID driver is required when installing a Windows® operating system on a hard disk drive that is included in a RAID set.



- **The motherboard does not provide a floppy drive connector.** You have to use a USB floppy disk drive when creating a **SATA** RAID driver disk.
- Windows® XP may not recognize the USB floppy disk drive due to Windows® XP limitation. To work around this OS limitation, refer to section **4.5.4 Using a USB floppy disk drive.**

### 4.5.1 Creating a RAID driver disk without entering the OS

To create a RAID driver disk without entering the OS:

1. Boot your computer.
2. Press <Del> during POST to enter the BIOS setup utility.
3. Set the optical drive as the primary boot device.
4. Insert the support DVD into the optical drive.
5. Save changes and exit BIOS.
6. When the **Make Disk** menu appears, press <1> to create a RAID driver disk.
7. Insert a formatted floppy disk into the USB floppy disk drive, then press <Enter>.
8. Follow the succeeding screen instructions to complete the process.

### 4.5.2 Creating a RAID driver disk in Windows®

To create a RAID driver disk in Windows®:

1. Start Windows®.
2. Plug the USB floppy disk drive and insert a floppy disk.
3. Place the motherboard support DVD into the optical drive.
4. Go to the **Make Disk** menu, and then click **Intel AHCI/RAID Driver Disk** to create a RAID driver disk.
5. Select USB floppy disk drive as the destination disk.
6. Follow the succeeding screen instructions to complete the process.



Write-protect the floppy disk to avoid a computer virus infection.

### 4.5.3 Installing the RAID driver during Windows® OS installation

To install the RAID driver in Windows® XP:

1. During the OS installation, the system prompts you to press the F6 key to install third-party SCSI or RAID driver.
2. Press <F6>, and then insert the floppy disk with RAID driver into the USB floppy disk drive.
3. When prompted to select the SCSI adapter to install, select the RAID driver for the corresponding OS version.
4. Follow the succeeding screen instructions to complete the installation.

To install the RAID driver for Windows® Vista or later OS:

1. During the OS installation, click **Load Driver** to allow you to select the installation media containing the RAID driver.
2. Insert the USB flash drive with RAID driver into the USB port or the support DVD into the optical drive, and then click **Browse**.
3. Click the name of the device you've inserted, go to **Drivers > RAID**, and then select the RAID driver for the corresponding OS version. Click **OK**.
4. Follow the succeeding screen instructions to complete the installation.



---

Before loading the RAID driver from a USB flash drive, you have to use another computer to copy the RAID driver from the support DVD to the USB flash drive.

---

## 4.5.4 Using a USB floppy disk drive

Due to OS limitation, Windows® XP may not recognize the USB floppy disk drive when you install the RAID driver from a floppy disk during the OS installation.

To solve this issue, add the USB floppy disk drive's Vendor ID (VID) and Product ID (PID) to the floppy disk containing the RAID driver. Refer to the steps below:

1. Using another computer, plug the USB floppy disk drive, and insert the floppy disk containing the RAID driver.

2. Right-click **My Computer** on the Windows® desktop or **start** menu, and then select **Manage** from the pop-up window.

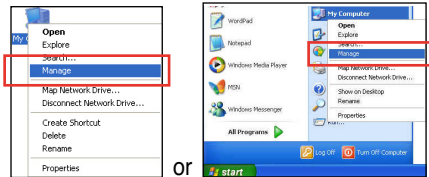

3. Select **Device Manager**. From the **Universal Serial Bus controllers**, right-click **xxxxxx USB Floppy**, and then select **Properties** from the pop-up window.



The name of the USB floppy disk drive varies with different vendors.

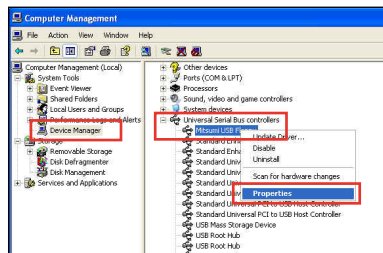

4. Click **Details** tab. The Vendor ID (VID) and Product ID (PID) are displayed.

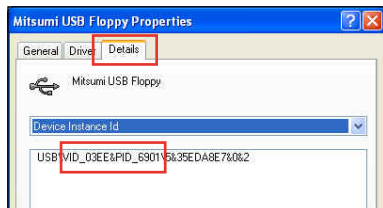

5. Browse the contents of the RAID driver disk to locate the file **txtsetup.oem**.

6. Double-click the file. A window appears, allowing you to select the program for opening the oem file.

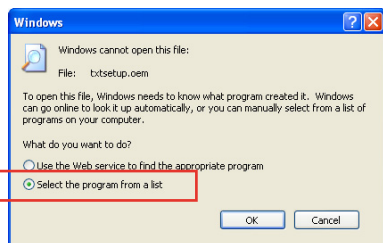

7. Use Notepad to open the file.

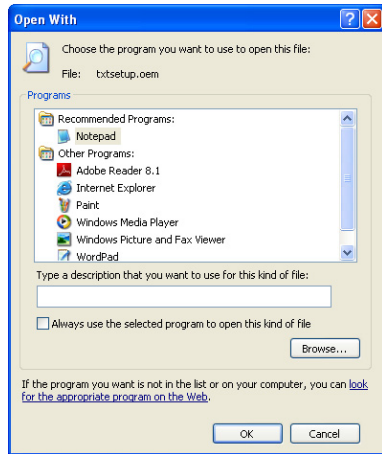

8. Find the **[HardwareIds.scsi.iaAHCI\_DesktopWorkstationServer]** and **[HardwareIds.scsi.iaStor\_DesktopWorkstationServer]** sections in the **txtsetup.oem** file.
9. Type the following line to the bottom of the two sections:  
**id = "USB\VID\_xxxx&PID\_xxxx", "usbstor"**

```
[HardwareIds.scsi.iaAHCI_DesktopWorkstationServer]
id= "PCI\VEN_8086&DEV_1C02&CC_0106", "iaStor"
id= "USB\VID_03EE&PID_6901", "usbstor"

[HardwareIds.scsi.iaStor_DesktopWorkstationServer]
id= "PCI\VEN_8086&DEV_2822&CC_0104", "iaStor"
id= "USB\VID_03EE&PID_6901", "usbstor"
```



\_\_\_\_\_

\_\_\_\_\_

Add the same line to both sections.



\_\_\_\_\_

\_\_\_\_\_

The VID and PID vary with different vendors.

10. Save and exit the file.



This chapter describes how to install and  
configure ATI® CrossFireX™ graphics  
cards.

# ATI® CrossFireX™ technology support



5.1	ATI® CrossFireX™ technology .....	5-1
5.2	NVIDIA® SLI™ technology .....	5-5

## 5.1 ATI® CrossFireX™ technology

The motherboard supports the ATI® CrossFireX™ technology that allows you to install multi-graphics processing units (GPU) graphics cards. Follow the installation procedures in this section.

### 5.1.1 Requirements

- You should have two identical CrossFireX-ready graphics cards or one CrossFireX-ready dual-GPU graphics card that are ATI® certified.
- Ensure that your graphics card driver supports the ATI CrossFireX technology. Download the latest driver from the AMD website at [www.amd.com](http://www.amd.com).
- Ensure that your power supply unit (PSU) can provide at least the minimum power required by your system. See page 2-40 for details.



- 
- We recommend that you install additional chassis fans for better thermal environment.
  - Visit the ATI Game website at <http://game.amd.com> for the latest certified graphics card and the supported 3D application list.
- 

### 5.1.2 Before you begin

For ATI CrossFireX to work properly, you have to uninstall all existing graphics card drivers before installing ATI CrossFireX graphics cards to your system.

To uninstall existing graphics card drivers

1. Close all current applications.
2. For Windows XP, go to **Control Panel > Add/Remove Programs**.  
For Windows Vista, go to **Control Panel > Programs and Features**.  
For Windows 7, go to **Control Panel > Programs > Uninstall a program**.
3. Select your current graphics card driver/s.
4. For Windows XP, select **Add/Remove**.  
For Windows Vista and 7, select **Uninstall**.
5. Turn off your computer.

### 5.1.3 Installing CrossFireX graphics cards



The following pictures are for reference only. The graphics cards and the motherboard layout may vary with models, but the installation steps remain the same.

1. Prepare two CrossFireX-ready graphics cards.
2. Insert the two graphics card into the PCIEX16 slots.
3. Ensure that the cards are properly seated on the slots.

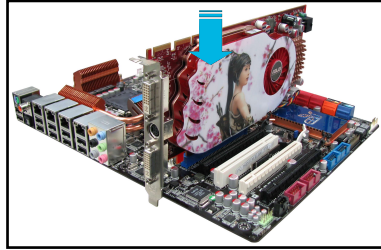

4. Align and firmly insert the CrossFireX bridge connector to the goldfingers on each graphics card. Ensure that the connector is firmly in place.

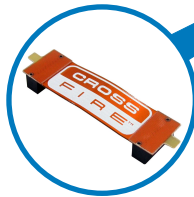
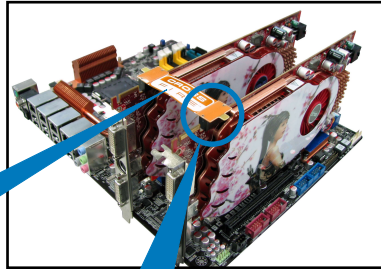

CrossFireX bridge

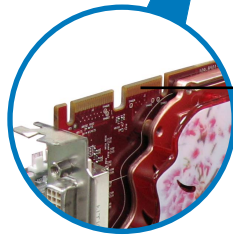

Goldfingers

5. Connect two independent auxiliary power sources from the power supply to the two graphics cards separately.
6. Connect a VGA or a DVI cable to the graphics card.

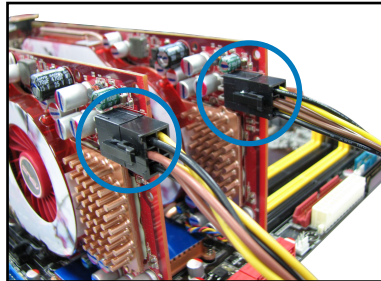

## 5.1.4 Installing the device drivers

Refer to the documentation that came with your graphics card package to install the device drivers.



Ensure that your PCI Express graphics card driver supports the ATI® CrossFireX™ technology. Download the latest driver from the AMD website ([www.amd.com](http://www.amd.com)).

## 5.1.5 Enabling the ATI® CrossFireX™ technology

After installing your graphics cards and the device drivers, enable the CrossFireX™ feature through the ATI Catalyst™ Control Center in Windows environment.

### Launching the ATI Catalyst Control Center

To launch the ATI Catalyst Control Center

1. Right-click on the Windows® desktop and select **Catalyst(TM) Control Center**. You can also right-click the ATI icon in the Windows notification area and select **Catalyst Control Center**.

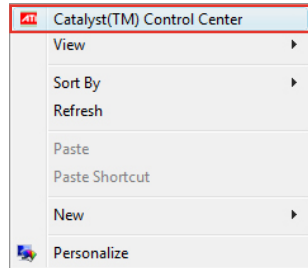

2. The **Catalyst Control Center Setup Assistant** appears when the system detects the existence of multi-graphics cards. Click **Go** to continue to the **Catalyst Control Center Advanced View** window.

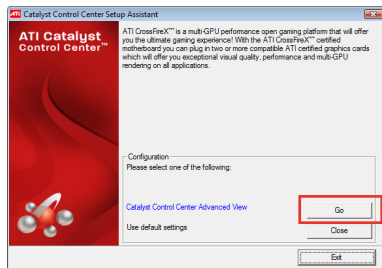

## Enabling CrossFireX settings

1. In the Catalyst Control Center window, click **Graphics Settings > CrossFireX > Configure**.
2. From the Graphics Adapter list, select the graphics card to act as the display GPU.
3. Select **Enable CrossFireX**.
4. Click **Apply**, and then click **OK** to exit the window.



## 5.2 NVIDIA® SLI™ technology

The motherboard supports the NVIDIA® SLI™ (Scalable Link Interface) technology that allows you to install multi-graphics processing units (GPU) graphics cards. Follow the installation procedures in this section.

### 5.2.1 Requirements

- In SLI mode, you should have two identical SLI-ready graphics cards that are NVIDIA® certified.
- Ensure that your graphics card driver supports the NVIDIA SLI technology. Download the latest driver from the NVIDIA website ([www.nvidia.com](http://www.nvidia.com)).
- Ensure that your power supply unit (PSU) can provide at least the minimum power required by your system. See Chapter 2 for details.



- We recommend that you install additional chassis fans for better thermal environment.
- Visit the NVIDIA zone website (<http://www.nzone.com>) for the latest certified graphics card and supported 3D application list.

### 5.2.2 Installing two SLI-ready graphics cards



The following pictures are for reference only. The graphics cards and the motherboard layout may vary with models, but the installation steps remain the same.

1. Prepare two SLI-ready graphics cards.
2. Insert the two graphics card into the PCIEX16 slots. If your motherboard has more than two PCIEX16 slots, refer to Chapter 2 in this user manual for the locations of the PCIEX16 slots recommended for multi-graphics card installation.
3. Ensure that the cards are properly seated on the slots.

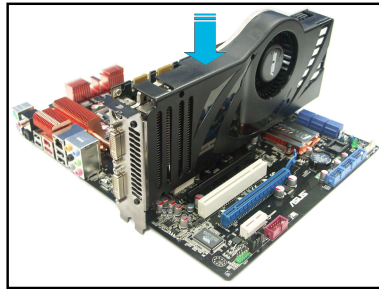

4. Align and firmly insert the SLI bridge connector to the goldfingers on each graphics card. Ensure that the connector is firmly in place.
5. Connect two independent auxiliary power sources from the power supply to the two graphics cards separately.
6. Connect a VGA or a DVI cable to the graphics card.

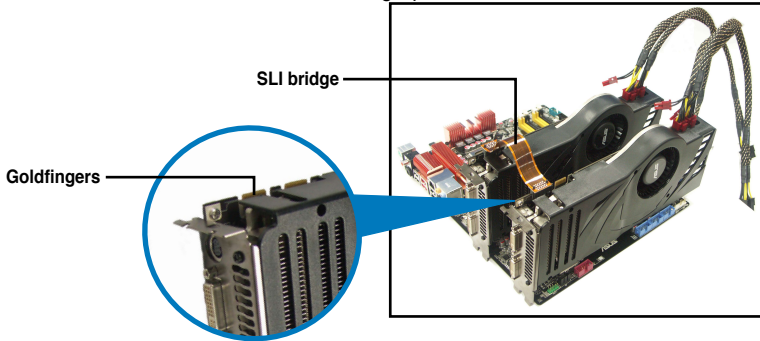

### 5.2.3 Installing the device drivers

Refer to the documentation that came with your graphics card package to install the device drivers.



Ensure that your PCI Express graphics card driver supports the NVIDIA® SLI™ technology. Download the latest driver from the NVIDIA website ([www.nvidia.com](http://www.nvidia.com)).

### 5.2.4 Enabling the NVIDIA® SLI™ technology

After installing your graphics cards and the device drivers, enable the SLI feature in NVIDIA® Control Panel under the Windows® Vista™ operating system.

#### Launching the NVIDIA Control Panel

You can launch the NVIDIA Control Panel by the following two methods.

- A. Right click on the empty space of the Windows® desktop and select **NVIDIA Control Panel**.  
The NVIDIA Control Panel window appears (See Step B5).

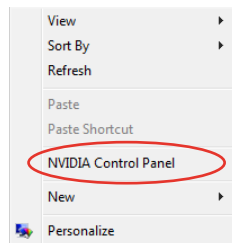



B1. If you cannot see the NVIDIA Control Panel item in step (A), select **Personalize**.

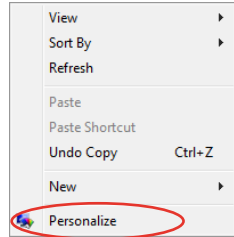

B2. From the **Personalization** window, select **Display Settings**.

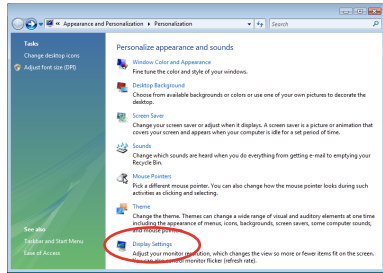

B3. From the Display Settings dialog box, click **Advanced Settings**.

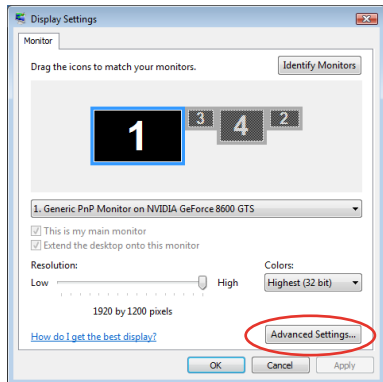

- B4. Select the NVIDIA GeForce tab, and then click **Start the NVIDIA Control Panel**.

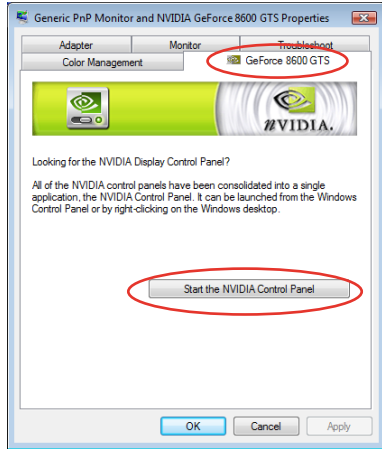

- B5. The NVIDIA Control Panel window appears.

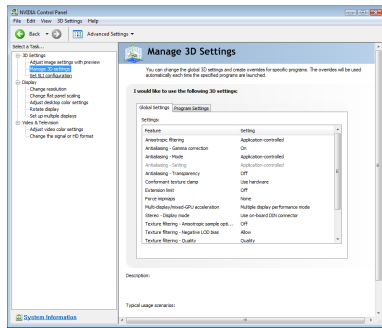

## Enabling SLI settings

From the NVIDIA Control Panel window, select **Set SLI Configuration**. Click **Enable SLI** and set the display for viewing SLI rendered content. When done, click **Apply**.

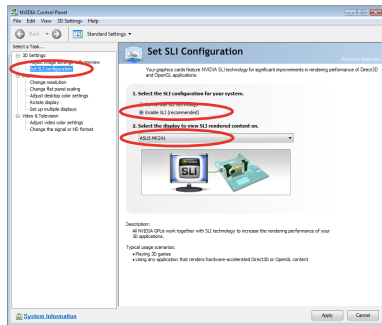

## **ASUS contact information**

### **ASUSTeK COMPUTER INC.**

Address 15 Li-Te Road, Peitou, Taipei, Taiwan 11259  
Telephone +886-2-2894-3447  
Fax +886-2-2890-7798  
E-mail info@asus.com.tw  
Web site www.asus.com.tw

#### ***Technical Support***

Telephone +86-21-38429911  
Online support support.asus.com

### **ASUS COMPUTER INTERNATIONAL (America)**

Address 800 Corporate Way, Fremont, CA 94539, USA  
Telephone +1-812-282-3777  
Fax +1-510-608-4555  
Web site usa.asus.com

#### ***Technical Support***

Telephone +1-812-282-2787  
Support fax +1-812-284-0883  
Online support support.asus.com

### **ASUS COMPUTER GmbH (Germany and Austria)**

Address Harkort Str. 21-23, D-40880 Ratingen, Germany  
Fax +49-2102-959911  
Web site www.asus.de  
Online contact www.asus.de/sales

#### ***Technical Support***

Telephone +49-1805-010923\*  
Support Fax +49-2102-9599-11\*  
Online support support.asus.com

**\*EUR 0.14/minute from a German fixed landline; EUR 0.42/minute from a mobile phone.**

# DECLARATION OF CONFORMITY

Per FCC Part 2 Section 2.1077(a)



Responsible Party Name: **Asus Computer International**

Address: **800 Corporate Way, Fremont, CA 94539.**

Phone/Fax No: **(510)739-3777/(510)608-4555**

hereby declares that the product

**Product Name : Motherboard**

**Model Number : RAMPAGE III BLACK EDITION**

Conforms to the following specifications:

- FCC Part 15, Subpart B, Unintentional Radiators
- FCC Part 15, Subpart C, Intentional Radiators
- FCC Part 15, Subpart E, Intentional Radiators

### Supplementary Information:

This device complies with part 15 of the FCC Rules. Operation is subject to the following two conditions: (1) This device may not cause harmful interference, and (2) this device must accept any interference received, including interference that may cause undesired operation.

Representative Person's Name : Steve Chang / President

*Steve Chang*

Signature : \_\_\_\_\_  
Date : **Feb. 14, 2011**

Ver. 110101

# EC Declaration of Conformity



We, the undersigned,

Manufacturer: **ASUSTek COMPUTER INC.**  
No. 150, LI-TE RD., PEITOU, TAIPEI 112, TAIWAN R.O.C.  
Country: **TAIWAN**  
Authorized representative in Europe: **ASUS COMPUTER GmbH**  
Address: **HARKORT STR. 21-23, 40860 RATINGSEN**  
Country: **GERMANY**

declare the following apparatus:

Product name : **Motherboard**  
Model name : **RAMPAGE III BLACK EDITION**

conform with the essential requirements of the following directives:

- 2004/109/EC-EMC Directive**
  - EN 55022:2006+A1:2007
  - EN 55024:1988+A1:2001+A2:2003
  - EN 55030:2008
  - EN 55035:2001+A1:2003+A2:2006
  - EN 55026:2007
- 1999/5/EC-R & TTE Directive**
  - EN 300 328 V1.1.1.(2006-05)
  - EN 300 440-1 V1.4.1.(2006-05)
  - EN 300 440-2 V1.2.1.(2006-03)
  - EN 301 571 V1.0.2.(2006-05)
  - EN 301 885 V1.4.1.(2006-05)
  - EN 301 888 V1.3.2.1.(2007-05)
  - EN 301 893 V1.4.1.(2006-03)
  - EN 302 544-2 V1.1.1.(2006-01)
  - EN 302 544-1 V1.1.1.(2006-01)
  - EN 303 607
  - EN 60371:2002
  - EN 60385:2002
- 2006/95/EC-LVD Directive**
  - EN 60950-1:2006
  - EN 60950-1:2006+A11:2009
- 2009/12/EC-EP Directive**
  - Regulation (EC) No. 1275/2008
  - EN 62301:2005
  - Regulation (EC) No. 642/2009
  - EN 62301:2005
- 2006/95/EC-LVD Directive**
  - EN 60065:2002+A1:2006+A11:2008

Regulation (EC) No. 279/2009  
 EN 62301:2005

Ver. 110101



(EC conformity marking)

Position : **CEO**  
Name : **Jerry Shen**

*Jerry Shen*

Signature : \_\_\_\_\_

Declaration Date: **Feb. 14, 2011**  
Year to begin affixing CE marking: **2011**

# DECLARATION OF CONFORMITY

Per FCC Part 2 Section 2.1077(a)



Responsible Party Name: **Asus Computer International**

Address: **800 Corporate Way, Fremont, CA 94539.**

Phone/Fax No: **(510)739-3777/(510)608-4555**

hereby declares that the product

**Product Name : Network/Sound Card**

**Model Number : THUNDERBOLT**

Conforms to the following specifications:

- FCC Part 15, Subpart B, Unintentional Radiators
- FCC Part 15, Subpart C, Intentional Radiators
- FCC Part 15, Subpart E, Intentional Radiators

### Supplementary Information:

This device complies with part 15 of the FCC Rules. Operation is subject to the following two conditions: (1) This device may not cause harmful interference, and (2) this device must accept any interference received, including interference that may cause undesired operation.

Representative Person's Name : Steve Chang / President

Signature :   
Date : Jan. 28, 2011

Ver. 110101

# EC Declaration of Conformity



Asus Innovation. Expert Performance

We, the undersigned,

Manufacturer: ASUSTeK COMPUTER INC.  
Address: No. 150, LITE RD., PEITOU, TAIPEI 112, TAIWAN R.O.C.  
Country: TAIWAN  
Authorized representative in Europe: ASUS COMPUTER GmbH  
Address: HARKORT STR. 21-23, 40880 RATINGEN  
Country: GERMANY

declare the following apparatus:

Product name : Network/Sound Card  
Model name : THUNDERBOLT

conform with the essential requirements of the following directives:

**2004/108/EC-EMC Directive**  
 EN 55024:2006  
 EN 61000-3-2:2006  
 EN 55013:2001+A1:2003+A2:2006

**1989/5/EC-R&TTE Directive**  
 EN 300 328 V1.7.1(2006-05)  
 EN 300 440-1 V1.4.1(2008-05)  
 EN 300 440-2 V1.4.1(2008-05)  
 EN 300 510 V1.0.2(2005-03)  
 EN 300 808-1 V3.2.1(2007-05)  
 EN 301 908-2 V3.2.1(2007-05)  
 EN 301 893 V1.4.1(2006-03)  
 EN 300 885 V1.1.1(2005-01)  
 EN 60360:2001  
 EN 60371:2002  
 EN 50385:2002

**2006/95/EC-LVD Directive**  
 EN 60950-1:2006  
 EN 60950-1:2006+A11:2009

**2009/125/EC-ERP Directive**  
Regulation (EC) No. 1275/2008  
 EN 62301:2005  
 EN 62301:2005

EN 60065:2002+A1:2006+A11:2008  
 EN 60065:2002+A1:2006+A11:2008

Regulation (EC) No. 278/2009  
 EN 62301:2005  
Regulation (EC) No. 642/2009  
 EN 62301:2005



(EC conformity marking)

Position : **CEO**  
Name : **Jerry Shen**



Declaration Date: **Jan. 28, 2011**  
Year to begin affixing CE marking: **2011**

Signature : \_\_\_\_\_

